



# SkyStar SK and SK-ECM

Cassette Fan Coil Unit

TECHNICAL LEAFLET

# SkyStar SK

Cassette Fan Coil Unit with Asynchronous Motor



Innovating and beautiful design, **seven different sizes**, high control flexibility, easy maintenance: the **SkyStar chilled water Cassette** is the result of an extended technical and design development aimed at achieving the highest level in terms of performance, silent operation and control possibilities.

The air diffuser has a highly attractive aesthetical appearance, very innovative, and is also able to offer the best air distribution performance thanks to in-depth computer studies and laboratory tests.

The 4 smaller sizes are designed to fit into **600x600 mm false ceiling** standard modules. The 3 bigger sizes have a **dimension of 800x800 mm** which allows the best outcome in terms of quietness and of price/performance ratio for these high capacity models.



In addition to temperature and speed standard controls, **automatic** speed selection is also available.

More than one unit can be connected to a single control, and the unit control panel can be installed in a remote position that **facilitates** the maintenance operation.

**All the SkyStar** units can be supplied in **MB version**. This version allows a wide range of controls, including the infra-red remote control, which can manage one single unit or several units by using the **Modbus RTU - RS 485** communication protocol.

The units can be connected to the most common automatic building management systems.



## Air diffusers

Intake grid, frame and adjustable air distribution louvers on each side, made from ABS.

---

### HTA version

white ABS, RAL 9003



---

### HTB version

intake grid, frame and louvers in a colour of choice



---

### HTC version

intake grid and louvers in a colour of choice, plus white ABS frame RAL 9003

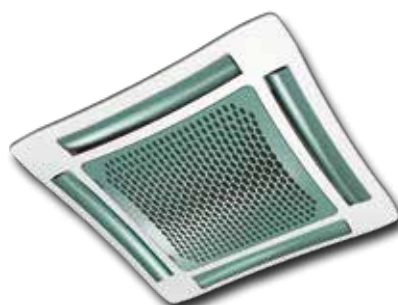

---

### HTD version

louvers in a colour of choice, while the grid and frame are made from ABS, RAL 9003

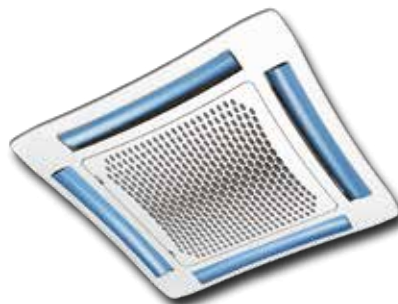

---

### MD-600 / MD-800 version

metal diffuser painted in RAL 9003 white colour to perfectly fit into the false ceiling standard modules without overlapping parts



**Casing:** made of galvanized steel with internal thermal insulation with polyolefin (PO) foam (B-s2-d0 EN 13501-1) and external anti-condensate lining.

**Control panel:** made of an external metallic box with control electronic board and easily accessible terminal board.

**Fan assembly:** the fan assembly, which is mounted on anti-vibrating supports, is extremely silent.

The radial fan has been designed to optimise performance, using wing profile blades with a shape that reduces turbulence, increasing efficiency and reducing noise.

The single air inlet radial fan is connected to a 6 speed electric motor with single phase 230 V / 50 Hz supply, class B insulation and integrated Klixon thermal contact for motor protection.

The units are supplied with 3 standard speeds connected and it is possible to change them on site if necessary.

**Coil:** made of copper tubes with bonded aluminium fins for maximum transfer contact. The coils have 1, 2 or 3 rows for 2 pipe models and 2+1 rows for 4 pipe models (the heating row is on the inside part of the coil).

For 4 pipe systems two versions are available:

- **SK 04, SK 14, SK 24, SK 34, SK 44, SK 54, SK 64** supply an higher heating emission;
- **SK 26, SK 36, SK 56, SK 66** supply an higher cooling emission.

The coil is not suitable for use in corrosive atmosphere or in environments where aluminium may be subject to corrosion.

**Condensate collection tray:** high density ABS polystyrene foam condensate tray, shaped in order to optimize the air diffusion, fire retardant rating B1 to DIN 4102.

**Air filter:** synthetic washable filter, easily removable.

**Condensate pump:** float switch centrifugal pump with 650 mm of maximum head, built into the unit and wired to the control panel on the outside of the casing.

**Valve set:** two or three way valves for ON/OFF operation, with pipe mounting kit and thermostatic actuator.

## SK 02-04 / SK 12-14 / SK 22-24-26 / SK 32-34-36 (Version 600 x 600)

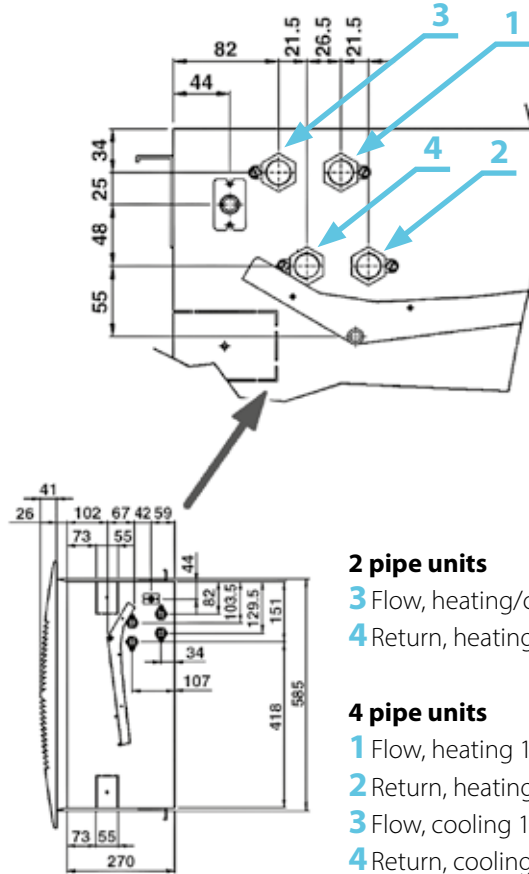
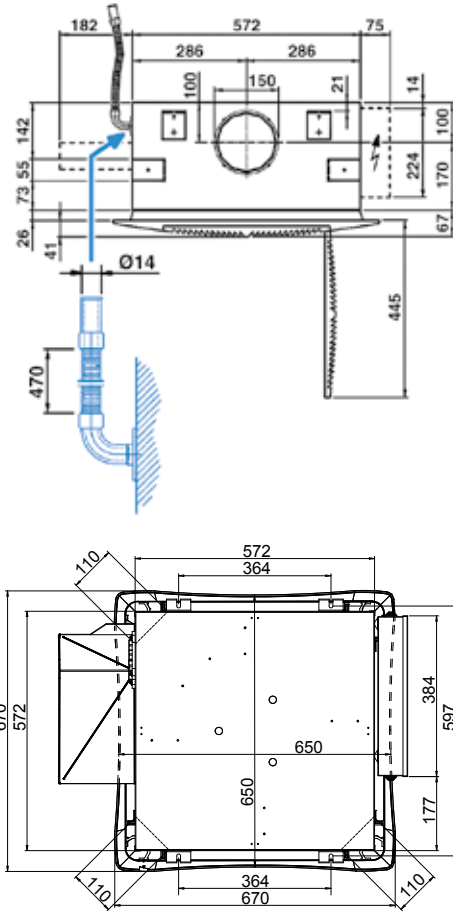

## Metal diffuser

MD-600

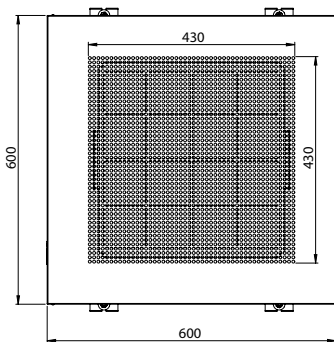

MD-800

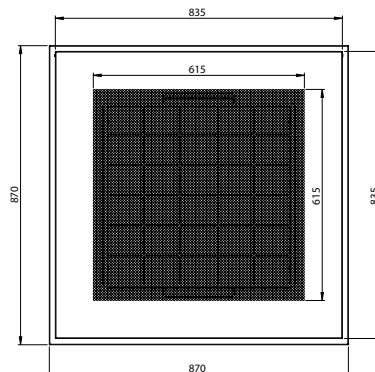

Model	Code
MD-600	9079420
MD-800	9079417

Model	Unit		Diffuser		Packed unit dimensions (mm)			
	Weight packed unit kg	Weight unpacked unit kg	Weight packed unit kg	Weight unpacked unit kg	A	B	C	D
SK 02 - 12	28	22	3,5	2,5	790	350	750	150
SK 04 - 14								
SK 22 - 24 - 26	30	24						
SK 32 - 34 - 36								

## DIMENSIONS AND WEIGHT

### SK 42-44 / SK 52-54-56 / SK 62-64-66 (Version 800 x 800)

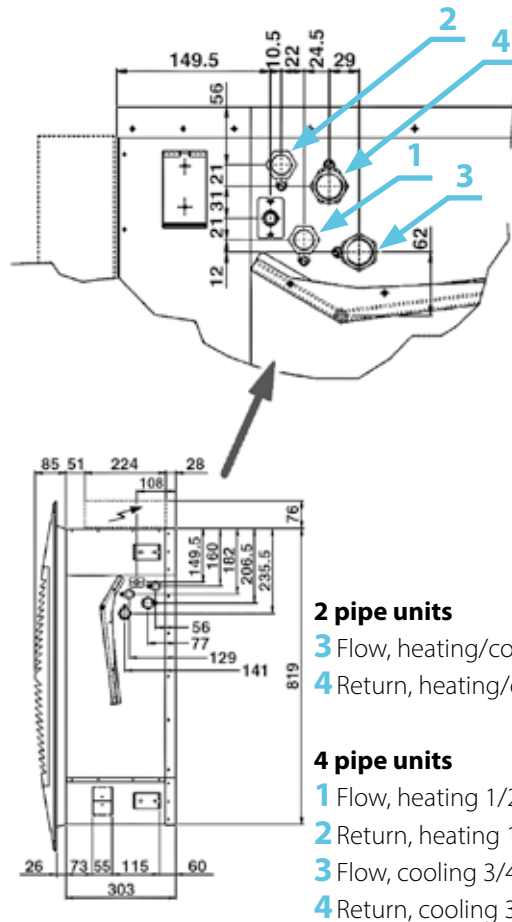
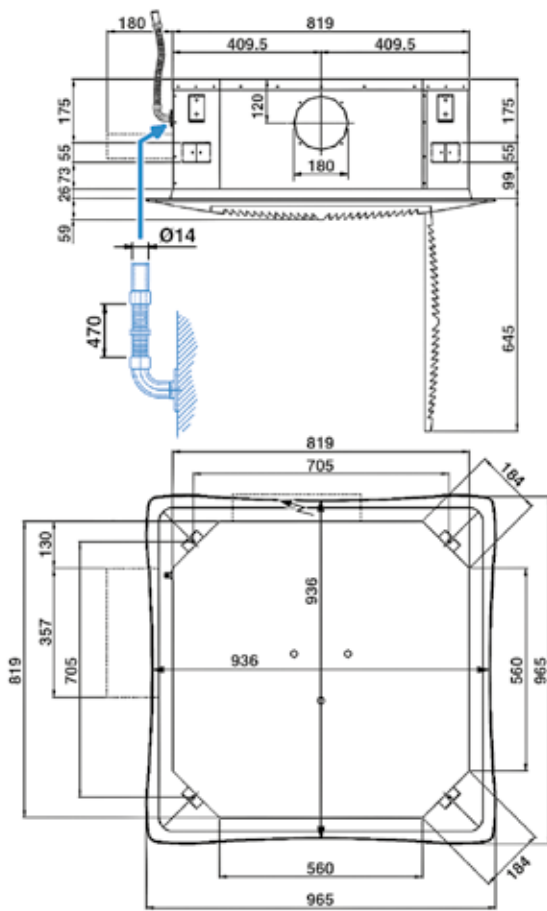

#### 2 pipe units

- 3 Flow, heating/cooling 3/4"
- 4 Return, heating/cooling 3/4"

#### 4 pipe units

- 1 Flow, heating 1/2"
- 2 Return, heating 1/2"
- 3 Flow, cooling 3/4"
- 4 Return, cooling 3/4"

### Unit

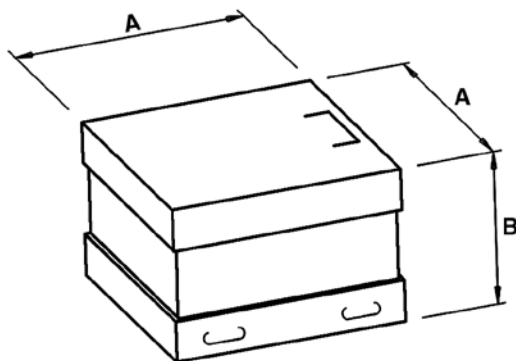

### Diffuser

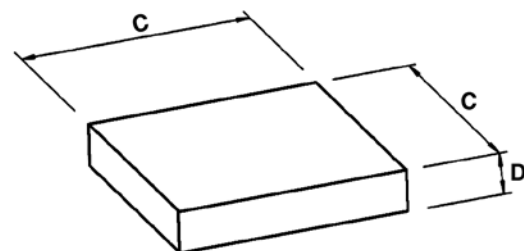

Model	Unit		Diffuser		Packed unit dimensions (mm)			
	Weight packed unit kg	Weight unpacked unit kg	Weight packed unit kg	Weight unpacked unit kg	A	B	C	D
SK 42	44	36	10	6	1050	400	1000	200
SK 44								
SK 52 - 54 - 56	47	39						
SK 62 - 64 - 66								

**2 pipe units.** The following standard rating conditions are used:

**COOLING (summer mode)**

**Entering air temperature:** +27°C d.b.      +19°C w.b.  
**Water temperature:**      +7°C E.W.T.      +12°C L.W.T.

**HEATING (winter mode)**

**Entering air temperature:** +20°C  
**Water temperature:**      +45°C E.W.T.      +40°C L.W.T.

Model		SK 02			SK 12			SK 22			SK 32		
		1	2	3	1	2	3	1	2	3	1	2	3
Speed													
Air flow	m <sup>3</sup> /h	310	420	610	310	420	520	320	500	710	430	610	880
Cooling total emission(E)	kW	1,25	1,60	1,92	1,82	2,31	2,64	2,23	3,30	4,26	2,91	3,82	4,93
Cooling sensible emission (E)	kW	0,99	1,29	1,58	1,33	1,72	2,00	1,55	2,35	3,11	2,05	2,75	3,65
Heating (E)	kW	1,38	1,80	2,24	1,85	2,42	2,80	2,12	3,28	4,37	2,85	3,85	5,15
Heating - Water 70-60°C	kW	2,80	3,66	4,56	4,19	4,91	5,68	4,83	6,96	9,25	6,10	8,25	10,63
Dp Cooling (E)	kPa	4,5	7,0	10,0	4,9	7,6	9,7	6,4	13,0	20,9	7,5	12,4	19,7
Dp Heating (E)	kPa	4,4	7,2	10,7	4,3	6,9	9,0	2,8	6,1	10,2	6,2	10,6	17,8
Sound power Lw (E)	dB(A)	33	40	49	33	40	45	33	45	53	41	49	59
Sound pressure Lp (*)	dB(A)	24	31	40	24	31	36	24	36	44	32	40	50
Fan (E)	W	25	32	57	25	32	44	25	44	68	32	57	90
	A	0,11	0,15	0,27	0,11	0,15	0,20	0,11	0,20	0,32	0,15	0,27	0,45
Water content	l	0,8	0,8	0,8	1,4	1,4	1,4	2,1	2,1	2,1	2,1	2,1	2,1
Dimensions	mm	575 x 575 x 275											

Model		SK 42			SK 52			SK 62		
		1	2	3	1	2	3	1	2	3
Speed										
Air flow	m <sup>3</sup> /h	630	820	1140	710	970	1500	710	1280	1820
Cooling total emission(E)	kW	4,18	4,86	6,08	5,27	6,72	9,39	5,27	8,36	10,93
Cooling sensible emission (E)	kW	3,00	3,53	4,51	3,42	4,42	6,36	3,67	6,00	8,08
Heating (E)	kW	4,27	5,03	6,50	4,92	6,40	9,23	5,12	8,55	11,72
Heating - Water 70-60°C	kW	8,61	10,16	13,14	10,25	13,43	19,76	10,25	17,26	23,68
Dp Cooling (E)	kPa	10,9	14,3	21,6	9,4	14,7	26,9	9,4	21,8	35,6
Dp Heating (E)	kPa	7,0	9,4	15,0	7,1	11,4	22,0	7,6	19,2	33,8
Sound power Lw (E)	dB(A)	33	40	48	34	40	53	34	48	58
Sound pressure Lp (*)	dB(A)	24	31	39	25	31	44	25	39	49
Fan (E)	W	33	48	77	42	63	120	42	95	170
	A	0,15	0,23	0,36	0,18	0,28	0,53	0,18	0,42	0,74
Water content	l	3,0	3,0	3,0	4,0	4,0	4,0	4,0	4,0	4,0
Dimensions	mm	820 x 820 x 303								

(E) = Eurovent certified performance.

(\*) = The sound pressure levels are 9 dB(A) lower than the sound power levels and apply to the reverberant field of a 100 m<sup>3</sup> room and a reverberation time of 0.5 sec.



**4 pipe units.** The following standard rating conditions are used:

**COOLING (summer mode)**

**Entering air temperature:** +27°C d.b.      +19°C w.b.  
**Water temperature:**      +7°C E.W.T.      +12°C L.W.T.

**HEATING (winter mode)**

**Entering air temperature:** +20°C  
**Water temperature:**      +65°C E.W.T.      +55°C L.W.T.

Model		SK 04			SK 14			SK 24			SK 26			SK 34			SK 36		
		1	2	3	1	2	3	1	2	3	1	2	3	1	2	3	1	2	3
Speed																			
Air flow	m <sup>3</sup> /h	310	420	610	310	420	520	310	500	710	320	500	710	430	610	880	430	610	880
Cooling total emission (E)	kW	1,49	1,93	2,27	1,83	2,33	2,66	1,83	2,61	3,27	2,07	3,02	3,86	2,33	2,96	3,72	2,69	3,47	4,44
Cooling sensible emission (E)	kW	1,13	1,52	1,84	1,32	1,68	1,94	1,32	1,94	2,49	1,47	2,20	2,88	1,72	2,23	2,88	1,94	2,56	3,37
Dp Cooling (E)	kPa	6,0	10,0	13,5	4,6	6,9	8,8	4,6	8,8	13,4	4,0	7,0	10,5	7,2	11,2	17,0	6,0	9,0	14,0
Heating (E)	kW	1,72	2,23	2,66	2,13	2,66	3,04	2,13	3,04	3,86	1,73	2,71	2,91	2,61	3,33	4,19	2,14	2,66	3,29
Dp Heating (E)	kPa	5,2	8,3	11,4	4,6	6,8	8,7	4,6	8,7	13,3	2,6	4,6	6,7	6,4	9,9	15,0	3,9	5,7	8,4
Sound power Lw (E)	dB(A)	33	40	49	33	40	45	33	45	53	33	45	53	41	49	59	41	49	59
Sound pressure Lp (*)	dB(A)	24	31	40	24	31	36	24	36	44	24	36	44	32	40	50	32	40	50
Fan (E)	W	25	32	57	25	32	44	25	44	68	25	44	68	32	57	90	32	57	90
	A	0,11	0,15	0,27	0,11	0,15	0,20	0,11	0,20	0,32	0,11	0,20	0,32	0,15	0,27	0,45	0,15	0,27	0,45
Cooling water content	l	1,0	1,0	1,0	1,4	1,4	1,4	1,4	1,4	1,4	1,7	1,7	1,7	1,4	1,4	1,4	1,7	1,7	1,7
Heating water content	l	0,6	0,6	0,6	0,7	0,7	0,7	0,7	0,7	0,7	0,5	0,5	0,5	0,7	0,7	0,7	0,5	0,5	0,5
Dimensions	mm	575 x 575 x 275																	

Model		SK 44			SK 54			SK 56			SK 64			SK 66		
		1	2	3	1	2	3	1	2	3	1	2	3	1	2	3
Speed																
Air flow	m <sup>3</sup> /h	630	820	1140	710	970	1500	710	970	1500	710	1280	1820	710	1280	1820
Cooling total emission (E)	kW	4,11	4,98	6,26	4,48	5,60	7,59	4,95	6,27	8,65	4,48	6,84	8,72	4,95	7,75	10,03
Cooling sensible emission (E)	kW	2,93	3,60	4,61	3,21	4,09	5,71	3,49	4,49	6,37	3,21	5,09	6,67	3,49	5,64	7,51
Dp Cooling (E)	kPa	8,8	12,5	18,9	10,3	15,4	26,9	9,0	14,0	25,0	10,3	22,1	34,7	9,0	20,0	32,0
Heating (E)	kW	5,21	6,33	8,02	5,69	7,15	9,66	4,59	5,63	7,50	5,69	8,80	11,16	4,59	6,78	8,58
Dp Heating (E)	kPa	7,9	11,2	17,2	9,3	14,0	24,0	4,9	7,0	11,8	9,3	20,3	31,2	4,9	9,9	15,0
Sound power Lw (E)	dB(A)	33	40	48	34	40	53	34	40	53	34	48	58	34	48	58
Sound pressure Lp (*)	dB(A)	24	31	39	25	31	44	25	31	44	25	39	49	25	39	49
Fan (E)	W	33	48	77	42	63	120	42	63	120	42	95	170	42	95	170
	A	0,15	0,23	0,36	0,18	0,28	0,53	0,18	0,28	0,53	0,18	0,42	0,74	0,18	0,42	0,74
Cooling water content	l	3,0	3,0	3,0	3,0	3,0	3,0	3,6	3,6	3,6	3,0	3,0	3,0	3,6	3,6	3,6
Heating water content	l	1,4	1,4	1,4	1,4	1,4	1,4	1,1	1,1	1,1	1,4	1,4	1,4	1,1	1,1	1,1
Dimensions	mm	820 x 820 x 303														

(E) = Eurovent certified performance.

(\*) = The sound pressure levels are 9 dB(A) lower than the sound power levels and apply to the reverberant field of a 100 m<sup>3</sup> room and a reverberation time of 0.5 sec.

**SK-MB** All the SkyStar units can be supplied in MB version. This version allows a wide range of controls, including the infra-red remote control, which can manage one single unit or several units by using the Modbus RTU - RS 485 communication protocol.



**SK-E** The Cassette 2 pipe models are available with electric heater that is controlled in place of the heating coil valve. The electric heater is controlled in place of the hot water valve and not as integration to it. The electric heater is hermetically sealed and supplied inside the coil pipes and therefore can be only factory mounted. The electric heaters of the units are for single phase 230V supply.

Model	Emission
<b>SK 12-E</b>	1500 W
<b>SK 22-E / SK 32-E</b>	2500 W
<b>SK 42-E / SK 52-E / SK 62-E</b>	3000 W

### Unit with remote electric board

On request the Skystar cassettes are available with electric control panel reachable from below and with the electric board that can be placed in a remote position.

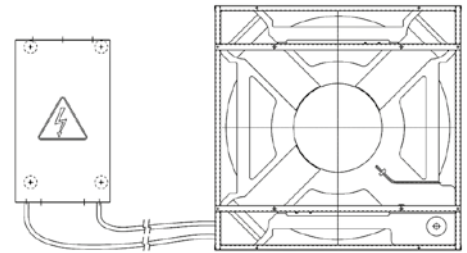

**MCT** The **MCT** version has been designed for all environments where false ceilings are not featured or cannot be constructed. The cover cabinet fits perfectly to the air intake and outlet diffuser, maintaining the appealing design that defines the SkyStar series. The water fittings can be turned to point upwards. The **MCT** series includes 7 models, with an installation height of up to 5 m, thanks to the highly flexible adjustment of the air distribution louvers. All the technical specifications described on the previous pages remain the same, while keeping in mind that the **MCT** series features one coil only (two pipe systems), there is no possibility of fresh air intake, there is no possibility of additional electric heater. The **MCT** version features a special casing delivered in separate packaging; this must only be fitted after having installed the SkyStar unit and completed the water and electrical connections.



**3 way ON-OFF valves with micrometric lockshield valve**

Valve set, 3 ways, ON-OFF, with thermoelectric actuator. The set includes connection pipes and holders.



SK 02-04 / 12-14 / 22-24-26 / 32-34-36

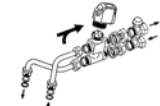

SK 42-44 / 52-54-56 / 62-64-66

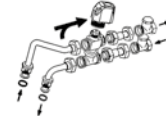

**2 way ON-OFF valves with micrometric lockshield valve**

Valve set, 2 ways, ON-OFF, with thermoelectric actuator. The set includes connection pipes and holders.



SK 02-04 / 12-14 / 22-24-26 / 32-34-36



SK 42-44 / 52-54-56 / 62-64-66



**3 way ON-OFF valves with simplified kit**

Valve set, 3 ways, ON-OFF, with thermoelectric actuator. The set includes connection pipes.



SK 02-04 / 12-14 / 22-24-26 / 32-34-36



SK 42-44 / 52-54-56 / 62-64-66

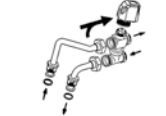

**2 way ON-OFF valves with simplified kit**

Valve set, 2 ways, ON-OFF, with thermoelectric actuator. The set includes connection pipes.



SK 02-04 / 12-14 / 22-24-26 / 32-34-36



SK 42-44 / 52-54-56 / 62-64-66



**V20VSK Balancing valves independent from the system pressure (Oventrop)**

(for main and additional coil)

**V2DFSK Balancing valves independent from the system pressure (Danfoss)**

(for main and additional coil)

**CDA Air distribution connection**

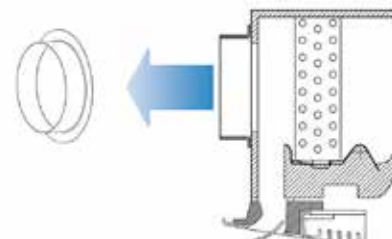

**CAP Fresh air connection**

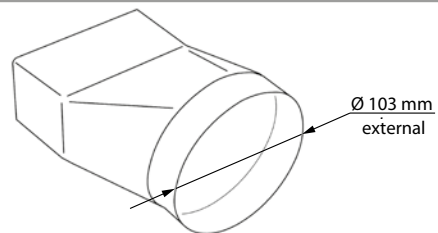

**PRT Fresh air kit**

This is used to introduce fresh air into the environment directly through the diffuser.

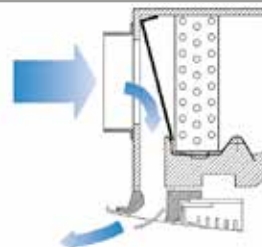

**PM-SK Fitted condensate pump with higher pressure head**

## IAQ accessory



SK / SK-ECM Cassette can be equipped with the innovative plate type electrostatic filter, **Crystall**, combining air treatment and purifying in a single product.

The electrostatic filter is **patented and certified** according to Standard EN 16890.

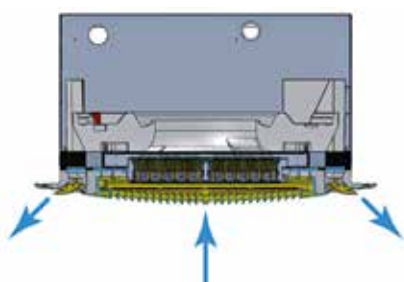

## Dimensions

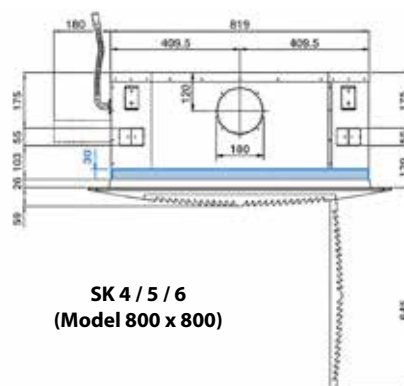
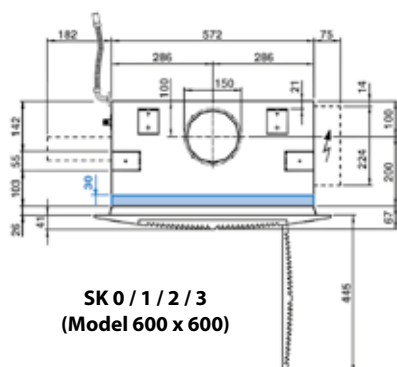

## Electronic wall controls

SK version	
<b>WM-3V</b>	3 speed control
<b>WM-T</b>	3 speed control with electronic thermostat and manual summer/winter switch
<b>WM-TQR</b>	3 speed control with electronic thermostat and centralized/manual summer/winter switch
<b>WM-AU</b>	Automatic speed control with electronic thermostat and summer/winter switch (to be used with UPM-AU or UP-AU only)
<b>T-MB2</b>	Wall control with LCD color display and WiFi (to be used with UPM-AU or UP-AU only)
<b>WM-503-AC-EC</b>	Automatic speed control with electronic thermostat to be mounted in the 503 box (to be used with UP-503-AC-EC only)
<b>T2T</b>	Electromechanical thermostat with summer/winter switch (only for 2 pipe units)
<b>UPM-AU</b>	UP-AU power unit for WM-AU and T-MB2 remote controls, fitted on the unit
<b>UP-AU</b>	UP-AU power unit for WM-AU and T-MB2 remote controls, not fitted on the unit
<b>UP-503-AC-EC</b>	UP-503-AC-EC power unit for WM-503-AC-EC remote control, not fitted on the unit

## Electronic controls

SK-MB version	
<b>T-MB2</b>	Wall control with LCD color display and WiFi (to be used with SK-MB version only)
<b>RCS-RT03</b>	RT03 infra-red remote control with receiver supplied with separate packaging (to be used with SK-MB version only)
<b>RT03</b>	RT03 infra-red remote control supplied with separate packaging (to be used with SK-MB version only)
<b>RCS</b>	Receiver for RT03 infra-red remote control supplied with separate packaging (to be used with SK-MB version only)
<b>RS</b>	Receiver for RT03 infra-red remote control, MD-600 and MD-800 metal diffuser supplied with separate packaging (to be used with SK-MB version only)
<b>PSM-DI</b>	PSM-DI multifunction control panel (to be used with SK-MB version only)
<b>T-DI</b>	T-DI touch screen multifunction control panel (to be used with SK-MB version only)
<b>SabWeb</b>	Web gateway for Sabiana Cloud (to be used with SK-MB version only)

Sabianet management system for a network of fan coils	
<b>Sabianet</b>	Sabianet (to be used with SK-MB version only)
<b>Router-S</b>	Router for Sabianet (default) or for BMS systems not provided by Sabiana
<b>SIOS</b>	Relay output board for Sabianet

## Controls for KNX systems

KNX systems	
<b>WM-KNX</b>	Wall control with electronic thermostat and summer/winter switch (to be used with UP-KNX and PL mounting plate only)
<b>UP-KNX</b>	UP-KNX power unit supplied with separate packaging
<b>PL-503-B</b>	Mounting plate for rectangular box
<b>PL-QUA-B</b>	Mounting plate for wall round or square box

NOTE: for more information about Controls and for full list of main Accessories, please see the dedicated pages.

# SkyStar SK-ECM

Cassette Fan Coil Unit with EC Brushless Electronic Motor and Inverter Board



The **SkyStar SK-ECM** series, available in **5 models**, uses an innovative brushless synchronous permanent magnet electronic motor controlled by an inverter board that is directly installed on the unit.

The air flow can be varied **continuously** with a 1-10 V signal from Sabiana controls or by independent controllers (programmable controllers with a 1-10 V output). The extreme efficiency, also at a low speed, makes it possible to greatly reduce the electric consumption (more **than 75% less** in comparison to a traditional motor) with absorption values, under normal operating conditions, that are **no greater than 10 Watt** in the entire range.



The brushless motor is characterised by a constant synchronous speed, independently of the applied load, that depends only on the motor power supply frequency, which is modulated by the inverter.

**It consumes less because:**

- The motor always works at its point of maximum efficiency.
- In the brushless motor, the rotor's permanent magnets generate the magnetising power autonomously.
- The motor always operates at the synchronous speed, as a result there are no induced currents that reduce efficiency

**The main advantages are**

- Large reduction in energy consumption, thanks to an optimal response to the thermal load of the environment during every moment of the day.
- Operating silence at all rotation speeds.
- Ability to operate at any rotation speed.

**All the SkyStar SK-ECM units can be supplied in MB version.** This version allows a wide range of controls, including the infra-red remote control, which can manage one single unit or several units by using the **Modbus RTU - RS 485** communication protocol.



## Air diffusers

Intake grid, frame and adjustable air distribution louvers on each side, made from ABS.

---

### HTA version

white ABS, RAL 9003



---

### HTB version

intake grid, frame and louvers in a colour of choice



---

### HTC version

intake grid and louvers in a colour of choice, plus white ABS frame RAL 9003

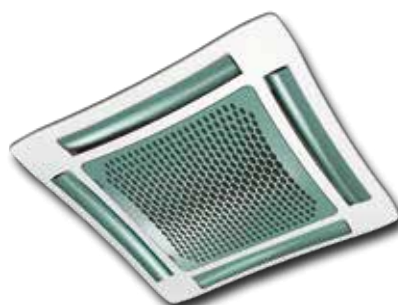

---

### HTD version

louvers in a colour of choice, while the grid and frame are made from ABS, RAL 9003

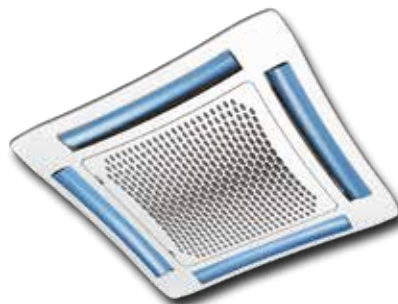

---

### MD-600 / MD-800 version

metal diffuser painted in RAL 9003 white colour to perfectly fit into the false ceiling standard modules without overlapping parts





**Casing:** made from galvanized steel with internal thermal insulation with polyolefin (PO) foam (B-s2-d0 EN 13501-1) and external anti-condensate lining.

**Control equipment:**

**SK-ECM** version: it consists of the pump control circuit board and the inverter circuit board.

**SK-ECM-MB** version: it consists of the MB board (that integrates pump control) and the inverter board.

**Fan assembly:** the fan assembly, which is mounted on anti-vibrating supports, is extremely silent.

The radial fan has been designed to optimise performance, using wing profile blades with a shape that reduces turbulence, increasing efficiency and reducing noise.

The fans are connected to a three phase permanent magnet brushless electronic motor that is controlled with reconstructed current according to a **BLAC** sinusoidal wave.

The inverter board that controls the motor operation is powered by 230 Volt, single-phase and, with a **switching system**, it generates a three-phase frequency modulated, wave form power supply.

The electric power supply required for the machine is therefore single-phase with voltage of **230 - 240 V** and frequency of **50 - 60 Hz**.

**Coil:** made of copper tubes with bonded aluminium fins for maximum transfer contact. The coils have 2 or 3 rows for 2 pipe models and 2+1 rows for 4 pipe models (the heating row is on the inside part of the coil).

For 4 pipe systems two versions are available

- **SK 14, SK 44** supply an higher heating emission
- **SK 26, SK 36, SK 56** supply an higher cooling emission.

The coil is not suitable for use in corrosive atmosphere or in environments where aluminium may be subject to corrosion

**Condensate collection tray:** high density ABS polystyrene foam condensate tray, shaped in order to optimize the air diffusion, fire retardant rating B1 to DIN 4102.

**Air filter:** synthetic washable filter, easily removable.

**Condensate pump:** float switch centrifugal pump with 650 mm of maximum head, built into the unit and wired to the control panel on the outside of the casing

**Valve set:** two or three way valves for ON/OFF operation, with pipe mounting kit and thermostatic actuator.

## SK 12-14 / SK 22-26 / SK 32-36 (Version 600 x 600)

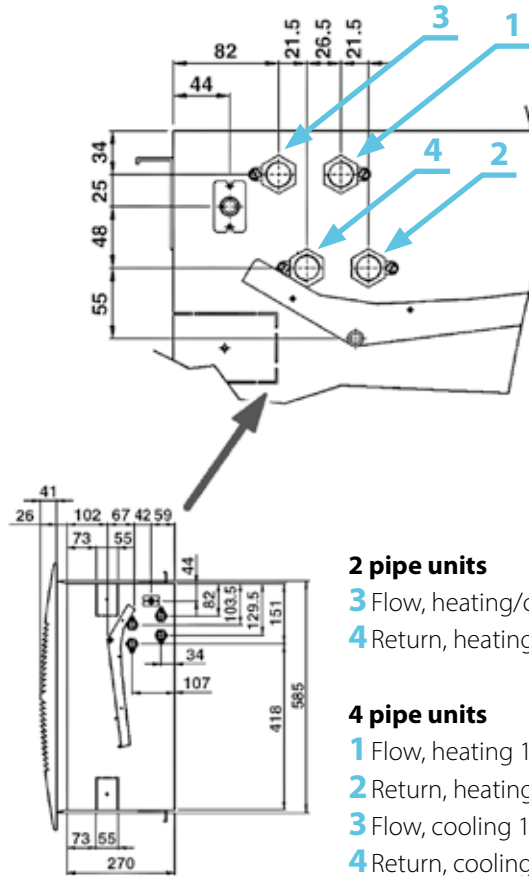
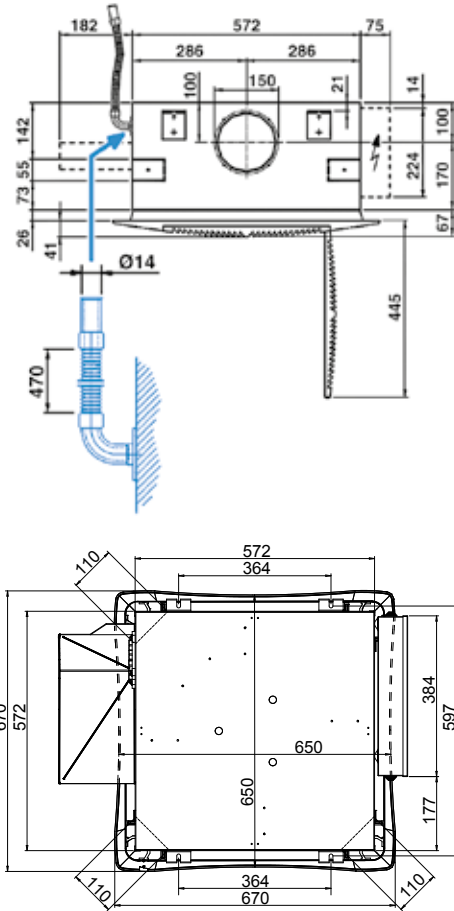

## Metal diffuser

MD-600

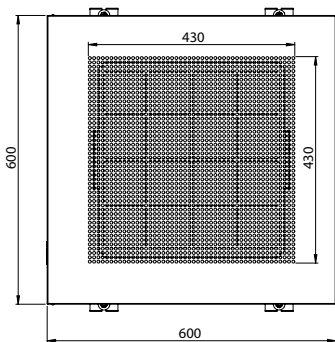

MD-800

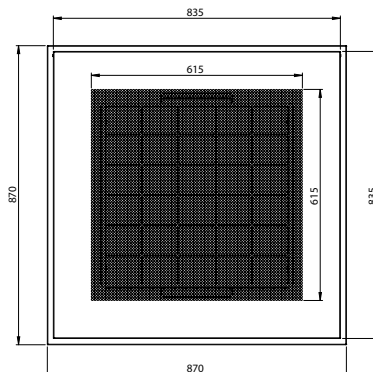

Model	Code
MD-600	9079420
MD-800	9079417

Model	Unit		Diffuser		Packed unit dimensions (mm)			
	Weight packed unit kg	Weight unpacked unit kg	Weight packed unit kg	Weight unpacked unit kg	A	B	C	D
SK 12	28	22	3,5	2,5	790	350	750	150
SK 14	30	24						
SK 22 - 26								
SK 32 - 36								

## DIMENSIONS AND WEIGHT

### SK 42-44 / SK 52-56 (Version 800 x 800)

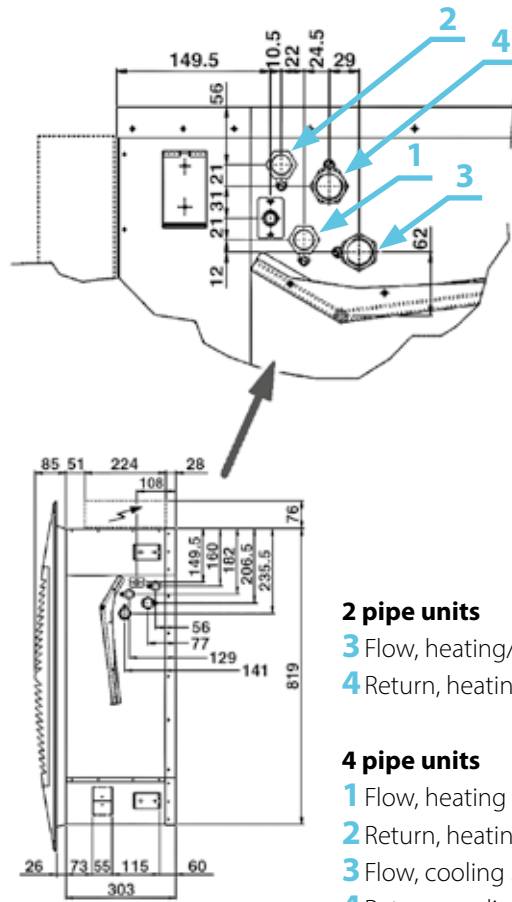
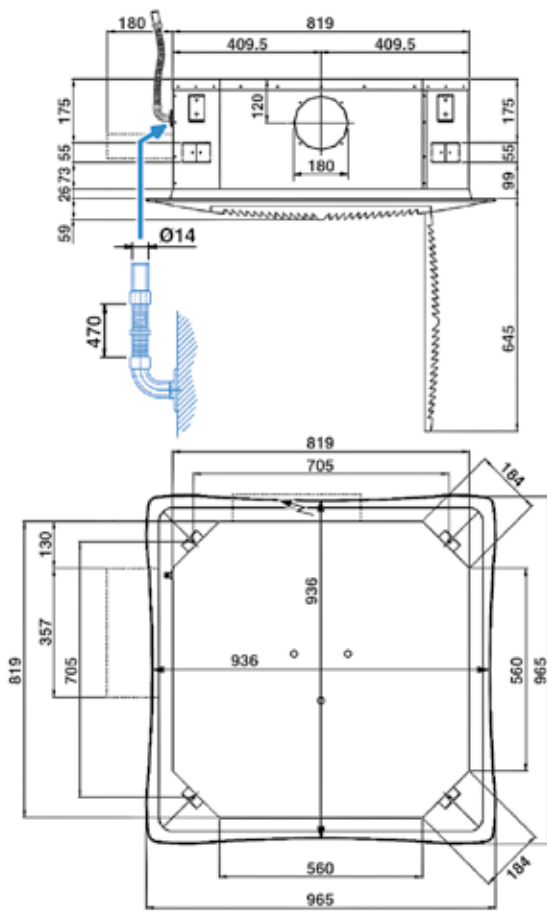

#### 2 pipe units

- 3 Flow, heating/cooling 3/4"
- 4 Return, heating/cooling 3/4"

#### 4 pipe units

- 1 Flow, heating 1/2"
- 2 Return, heating 1/2"
- 3 Flow, cooling 3/4"
- 4 Return, cooling 3/4"

### Unit

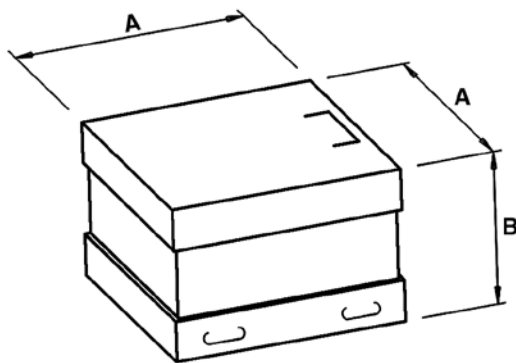

### Diffuser

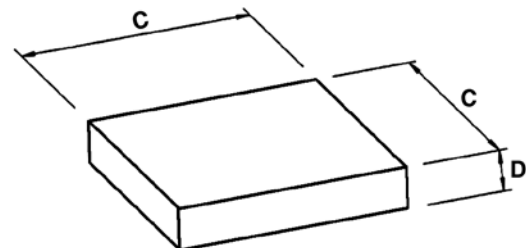

Model	Unit		Diffuser		Packed unit dimensions (mm)			
	Weight packed unit kg	Weight unpacked unit kg	Weight packed unit kg	Weight unpacked unit kg	A	B	C	D
SK 42	44	36	10	6	1050	400	1000	200
SK 44	47	39						
SK 52 - 56								

**2 pipe units.** The following standard rating conditions are used:

**COOLING (summer mode)**

**Entering air temperature:** +27°C d.b.      +19°C w.b.  
**Water temperature:** +7°C E.W.T.      +12°C L.W.T.

**HEATING (winter mode)**

**Entering air temperature:** +20°C  
**Water temperature:** +45°C E.W.T.      +40°C L.W.T.

Model		SK-ECM 12			SK-ECM 22			SK-ECM 32			SK-ECM 42			SK-ECM 52		
		1	5	10	1	5	10	1	5	10	1	5	10	1	5	10
Inverter Power (V)																
Speed		<b>MIN</b>	<b>MED</b>	<b>MAX</b>	<b>MIN</b>	<b>MED</b>	<b>MAX</b>	<b>MIN</b>	<b>MED</b>	<b>MAX</b>	<b>MIN</b>	<b>MED</b>	<b>MAX</b>	<b>MIN</b>	<b>MED</b>	<b>MAX</b>
Air flow	m <sup>3</sup> /h	310	380	535	310	445	710	360	610	880	630	870	1165	710	1130	1770
Cooling total emission (E)	kW	1,84	2,16	2,73	2,24	3,04	4,30	2,55	3,85	4,96	4,20	5,13	6,30	5,28	7,69	10,69
Cooling sensible emission (E)	kW	1,35	1,60	2,07	1,57	2,16	3,15	1,80	2,79	3,68	3,02	3,75	4,69	3,68	5,50	7,83
Heating (E)	kW	1,85	2,22	2,87	2,12	2,98	4,36	2,46	3,85	5,15	4,27	5,30	6,70	4,90	7,34	10,56
Heating - Water 70-60 °C	kW	3,75	4,51	5,82	4,28	6,01	8,81	4,96	7,79	10,42	8,61	10,72	13,54	9,87	14,82	21,37
Dp Cooling (E)	kPa	4,9	6,6	10,1	4,6	11,0	15,1	5,9	12,4	19,7	10,9	15,6	22,7	9,4	18,5	33,0
Dp Heating (E)	kPa	4,3	5,9	9,4	3,6	6,6	13,2	4,7	10,6	17,8	9,6	14,2	21,6	7,0	14,6	28,1
Fan (E)	W	5	8	16	5	11	31	7	21	62	10	17	33	10	32	108
Sound power Lw (E)	dB(A)	33	39	47	33	43	54	37	50	60	33	39	48	34	47	57
Sound pressure Lp (*)	dB(A)	24	30	38	24	34	45	28	41	51	24	30	39	25	38	48
Water content	l	1,4	1,4	1,4	2,1	2,1	2,1	2,1	2,1	2,1	3,0	3,0	3,0	4,0	4,0	4,0
Dimensions	mm	575 x 575 x 275									820 x 820 x 303					

**4 pipe units.** The following standard rating conditions are used:

**COOLING (summer mode)**

**Entering air temperature:** +27°C d.b.      +19°C w.b.  
**Water temperature:** +7°C E.W.T.      +12°C L.W.T.

**HEATING (winter mode)**

**Entering air temperature:** +20°C  
**Water temperature:** +65°C E.W.T.      +55°C L.W.T.

Model		SK-ECM 14			SK-ECM 26			SK-ECM 36			SK-ECM 44			SK-ECM 56		
		1	5	10	1	5	10	1	5	10	1	5	10	1	5	10
Inverter Power (V)																
Speed		<b>MIN</b>	<b>MED</b>	<b>MAX</b>	<b>MIN</b>	<b>MED</b>	<b>MAX</b>	<b>MIN</b>	<b>MED</b>	<b>MAX</b>	<b>MIN</b>	<b>MED</b>	<b>MAX</b>	<b>MIN</b>	<b>MED</b>	<b>MAX</b>
Air flow	m <sup>3</sup> /h	310	380	535	310	445	710	360	610	880	630	870	1165	710	1130	1770
Cooling total emission (E)	kW	1,85	2,17	2,75	2,09	2,81	3,90	2,37	3,51	4,47	4,29	5,29	6,48	4,97	7,14	9,76
Cooling sensible emission (E)	kW	1,20	1,42	1,84	1,49	2,03	2,92	1,70	2,60	3,40	3,07	3,82	4,80	3,51	5,17	7,29
Heating (E)	kW	2,13	2,51	3,18	1,73	2,20	2,91	1,92	2,66	3,29	5,41	6,65	8,24	4,58	6,27	8,33
Dp Cooling (E)	kPa	4,6	6,2	9,5	3,3	5,6	10,3	4,1	8,4	13,1	9,4	13,6	19,8	8,8	17,0	30,1
Dp Heating (E)	kPa	4,6	6,1	9,4	2,6	4,1	6,7	3,2	5,7	8,4	8,5	12,3	18,1	4,9	8,6	14,3
Fan (E)	W	5	8	16	5	11	31	7	21	62	10	17	33	10	32	108
Sound power Lw (E)	dB(A)	33	39	47	33	43	54	37	50	60	33	39	48	34	47	57
Sound pressure Lp (*)	dB(A)	24	30	38	24	34	45	28	41	51	24	30	39	25	38	48
Cooling water content	l	1,4	1,4	1,4	1,7	1,7	1,7	1,7	1,7	1,7	3,0	3,0	3,0	3,6	3,6	3,6
Heating water content	l	0,7	0,7	0,7	0,5	0,5	0,5	0,5	0,5	0,5	1,4	1,4	1,4	1,1	1,1	1,1
Dimensions	mm	575 x 575 x 275									820 x 820 x 303					

(E) = Eurovent certified performance.

(\*) = The sound pressure levels are 9 dB(A) lower than the sound power levels and apply to the reverberant field of a 100 m<sup>3</sup> room and a reverberation time of 0.5 sec.

**SK-ECM-MB** All the SkyStar ECM units can be supplied in MB version.

This version allows a wide range of controls, including the infra-red remote control, which can manage one single unit or several units by using the Modbus RTU - RS 485 communication protocol.



**SK-ECM-E** The Cassette 2 pipe models are available with electric heater that is controlled in place of the heating coil valve. The electric heater is controlled in place of the hot water valve and not as integration to it. The electric heater is hermetically sealed and supplied inside the coil pipes and therefore can be only factory mounted. The electric heater of the units are for single phase 230V supply.

ECM Model	Emission
<b>SK 12-E</b>	1500 W
<b>SK 22-E / SK 32-E</b>	2500 W
<b>SK 42-E / SK 52-E</b>	3000 W

**MCT** The **MCT** version has been designed for all environments where false ceilings are not featured or cannot be constructed. The cover cabinet fits perfectly to the air intake and outlet diffuser, maintaining the appealing design that defines the SkyStar series. The water fittings can be turned to point upwards. The **MCT** series includes 7 models, with an installation height of up to 5 m, thanks to the highly flexible adjustment of the air distribution louvers. All the technical specifications described on the previous pages remain the same, while keeping in mind that the **MCT** series features one coil only (two pipe systems), there is no possibility of fresh air intake, there is no possibility of additional electric heater. The **MCT** version features a special casing delivered in separate packaging; this must only be fitted after having installed the SkyStar unit and completed the water and electrical connections.



## 3 way ON-OFF valves with micrometric lockshield valve

Valve set, 3 ways, ON-OFF, with thermoelectric actuator.  
The set includes connection pipes and holders.



SK 12-14 / 22-26 / 32-36

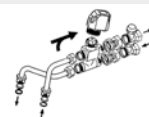

SK 42-44 / 52-56

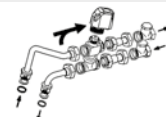

## 2 way ON-OFF valves with micrometric lockshield valve

Valve set, 2 ways, ON-OFF, with thermoelectric actuator.  
The set includes connection pipes and holders.



SK 12-14 / 22-26 / 32-36



SK 42-44 / 52-56



## 3 way ON-OFF valves with simplified kit

Valve set, 3 ways, ON-OFF, with thermoelectric actuator.  
The set includes connection pipes.



SK 12-14 / 22-26 / 32-36

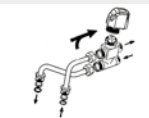

SK 42-44 / 52-56

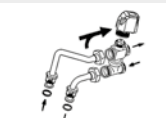

## 2 way ON-OFF valves with simplified kit

Valve set, 2 ways, ON-OFF, with thermoelectric actuator.  
The set includes connection pipes.



SK 12-14 / 22-26 / 32-36



SK 42-44 / 52-56



## V20VSK Balancing valves independent from the system pressure (Oventrop) (for main and additional coil)

## V2DFSK Balancing valves independent from the system pressure (Danfoss) (for main and additional coil)

## CDA Air distribution connection

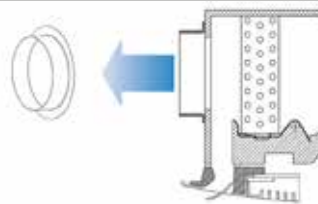

## CAP Fresh air connection

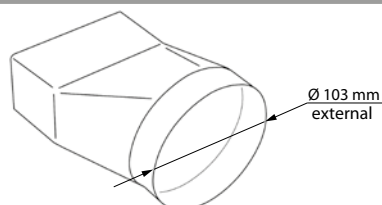

**PRT Fresh air kit**

This is used to introduce fresh air into the environment directly through the diffuser.

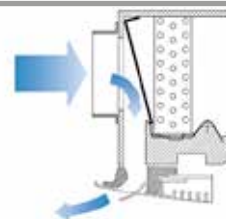

**PM-SK Fitted condensate pump with higher pressure head**

**IAQ accessory** refer to “IAQ accessory” at “SkyStar SK accessories” section pages

**Electronic wall controls**

SK-ECM version	
<b>WM-AU</b>	Automatic speed control with electronic thermostat and summer/winter switch (to be used with UPM-AU or UP-AU only)
<b>T-MB2</b>	Wall control with LCD color display and WiFi (to be used with UPM-AU or UP-AU only)
<b>WM-503-AC-EC</b>	Automatic speed control with electronic thermostat to be mounted in the 503 box (to be used with UP-503-AC-EC only)
<b>WM-S-ECM</b>	Continuous fan speed control with electronic thermostat, summer/winter switch and liquid crystal display
<b>UPM-AU</b>	UP-AU power unit for WM-AU and T-MB2 remote controls, fitted on the unit
<b>UP-AU</b>	UP-AU power unit for WM-AU and T-MB2 remote controls, not fitted on the unit
<b>UP-503-AC-EC</b>	UP-503-AC-EC power unit for WM-503-AC-EC remote control, not fitted on the unit

**Electronic controls**

SK-ECM-MB version	
<b>T-MB2</b>	Wall control with LCD color display and WiFi (to be used with SK-ECM-MB version only)
<b>RCS-RT03</b>	RT03 infra-red remote control with receiver supplied with separate packaging (to be used with SK-ECM-MB version only)
<b>RT03</b>	RT03 infra-red remote control supplied with separate packaging (to be used with SK-ECM-MB version only)
<b>RCS</b>	Receiver for RT03 infra-red remote control supplied with separate packaging (to be used with SK-ECM-MB version only)
<b>RS</b>	Receiver for RT03 infra-red remote control, MD-600 and MD-800 metal diffuser supplied with separate packaging (to be used with SK-ECM-MB version only)
<b>PSM-DI</b>	PSM-DI multifunction control panel (to be used with SK-ECM-MB version only)
<b>T-DI</b>	T-DI touch screen multifunction control panel (to be used with SK-MB version only)
<b>SabWeb</b>	Web gateway for Sabiana Cloud (to be used with SK-MB version only)

Sabianet management system for a network of fan coils	
<b>Sabianet</b>	Sabianet (to be used with SK-ECM-MB version only)
<b>Router-S</b>	Router for Sabianet (default) or for BMS systems not provided by Sabiana
<b>SIOS</b>	Relay output board for Sabianet

**Controls for KNX systems**

KNX systems	
<b>WM-KNX</b>	Wall control with electronic thermostat and summer/winter switch (to be used with UP-KNX and PL mounting plate only)
<b>UP-KNX</b>	UP-KNX power unit supplied with separate packaging
<b>PL-503-B</b>	Mounting plate for rectangular box
<b>PL-QUA-B</b>	Mounting plate for wall round or square box

NOTE: for more information about Controls and for full list of main Accessories, please see the dedicated pages.



A company of Arbonia Group  
**ARBONIA** 

Follow us on



Sabiana app



---

**SABIANA SpA**

Società a socio unico

Via Piave 53 - 20011 Corbetta (MI) Italia

T. +39 02 97203 1 r.a. • F. +39 02 9777282

info@sabiana.it

**www.sabiana.it**