



Multi Variable Air Conditioners Cassette Type Indoor Unit

Owner's Manual

Commercial Air Conditioners

Models:

AMV-R28T/Na-K	AMVL-R28T/Na-K
AMV-R36T/Na-K	AMVL-R36T/Na-K
AMV-R45T/Na-K	AMVL-R45T/Na-K
AMV-R50T/Na-K	AMVL-R50T/Na-K
AMV-R56T/Na-K	AMVL-R56T/Na-K
AMV-R63T/Na-K	AMVL-R63T/Na-K
AMV-R71T/Na-K	AMVL-R71T/Na-K
AMV-R80T/Na-K	AMVL-R80T/Na-K
AMV-R90T/Na-K	AMVL-R90T/Na-K
AMV-R100T/Na-K	AMVL-R100T/Na-K
AMV-R112T/Na-K	AMVL-R112T/Na-K
AMV-R125T/Na-K	AMVL-R125T/Na-K
AMV-R140T/Na-K	AMVL-R140T/Na-K

Thank you for choosing Commercial Air Conditioners, please read this owner's manual carefully before operation and retain it for future reference.

USER NOTICES

- ☆ When operating, the entire capacity of the cooperating indoor units should be no larger than that of the outdoor unit; otherwise, it would cause the shortage of cooling (heating) capacity.
- ☆ A breaker (or fuse) needs to be installed in every indoor unit, its capacity should accord with the indoor unit's electrical parameter and it is capable of preventing short circuits and abnormal overload. All the indoor units are required to be centralized controlled by a main switch, which can cut off the electric power supply in case of emergency. Before carrying out the clearing and maintenance work to the indoor units, it is necessary to turn off the main power supply switch.
- ☆ In order to turn on the units successfully, the main power switch should be switched on 8 hours before the operation.
- ☆ After receiving the turn-off signal, every indoor unit will continue to work for another 20-70s to make use of the rest cool air or the rest heat air in the heat exchanger for preparing for the next operation, which is absolutely normal.
- ☆ When the operating mode of the indoor unit clashes with that of the outdoor unit, the malfunction light will blink after 5s on the indoor unit, then the indoor unit will stop. At this time, change the operation mode of the indoor unit to the one that would be compatible with that of the outdoor unit so as to make the operation return to normal. The cooling mode won't clash with the dry mode, while the fan mode won't clash with any mode.
- ☆ The appliance shall not be installed in the laundry.
- ☆ An all-pole disconnection switch having a contact separation of at least 3mm among all poles should be connected in the fixed wiring.
- ☆ The main switch provided by the end user should be black or gray and be locked in the "OFF" position with the padlock.
- ☆ The main disconnection device should be explained in the user manual and the height should be recommended at 0.6-1.7m. Also, over current protection is required (EN 60947-3, EN 60947-2).
- ☆ Do not dispose this product as unsorted municipal waste. Collection of such waste separately for special treatment is necessary.
- ☆ Before obtaining access to terminals, all supply circuits must be disconnected.
- ☆ This appliance is not intended for use by persons (including children) with reduced physical, sensory or mental capabilities, or lack of experience and knowledge, unless they have been given supervision or instruction concerning use of the appliance by a person responsible for their safety.
- ☆ Children should be supervised to ensure that they do not play with this appliance.

CONTENTS

1 Safety Information	1
2 Installation of the Cassette Type Indoor Unit.....	2
2.1 Schematic Diagram of Installation Spaces	2
2.2 Selection of the Installation Location of the Indoor Unit.....	2
2.3 Important Notices.....	3
2.4 Dimension of the Ceiling Opening and Location of the Hoisting Screw (M10)	3
2.5 Main body for Hoisting the Air Conditioner.....	4
2.6 Connection of the Refrigerant Pipe.....	5
2.7 Drainage Hose	5
2.8 Drain Raising Pipe	7
2.9 Drainage Check	7
2.10 Electrical Wiring	7
2.11 Function Description of Functional DIP Switch S7	8
2.12 Installation of the Panel.....	9
3 Structure and Part Name of the Cassette Type Indoor Unit	11
4 Working Temperature Range.....	11
5 Wired Controller and Wireless Controller	12
5.1 Wired Controller	12
5.2 Wireless Controller.....	18
6 Operation Method in Case of Emergency	22
7 Troubleshooting.....	23
8 Maintenance	24

1 Safety Information

- (1). Please read this manual carefully before using this unit, and operate it correctly according to the guide in this manual.
- (2). Please take special note of the meaning of two marks below.

 **Warning!** This mark means that it may cause casualty or badly hurt if the operation is incorrect.

 **Note!** This mark means that it may cause casualty or property loss if the operation is incorrect.

 **Warning!**

- Do not use the fuse with unsuitable capacity or iron thread instead of the fuse, otherwise some malfunction or fire may happen.
- Cut down the main power switch immediately if some malfunction happens (such as burning odor etc.).
- Maintain ventilation to prevent oxygen depletion in the room.
- Don't insert finger or stick like things into the discharge vent or outlet grill.
- Please make sure that the unit is installed in the place which can bear the weight of it adequately. If the place is not strong enough, the air conditioner may drop and cause a casualty event.
- Don't spray or smear any oil paint or insecticide on the surface of the unit, otherwise, fire may be caused.
- Do not refit the conditioner. Please contact the agency or professional personnel to repair or move the conditioner.

 **Note!**

Please check and make sure that the cord, drainage pipe and tubes are connected in the correct way to prevent leakage of water, refrigerant, electric shock or fire.

- The main power must be connectable to the earth in order to assure the conditioner earthed effectively and to prevent electric shock. Please don't connect the earth lead with the gas pipe, water pipe, lightning rod or the telephone line.
- The air conditioner should be turned off at least after 5 minutes' operation; otherwise it would affect the duration of the unit.
- Don't let the children operate the air conditioner.
- Please don't operate the unit by wet hands.
- Please turn off the main power of the unit before cleaning the conditioner or change the filter.
- Please cut off the main power if the conditioner is not to be used for long time.

2 Installation of the Cassette Type Indoor Unit

2.1 Schematic Diagram of Installation Spaces

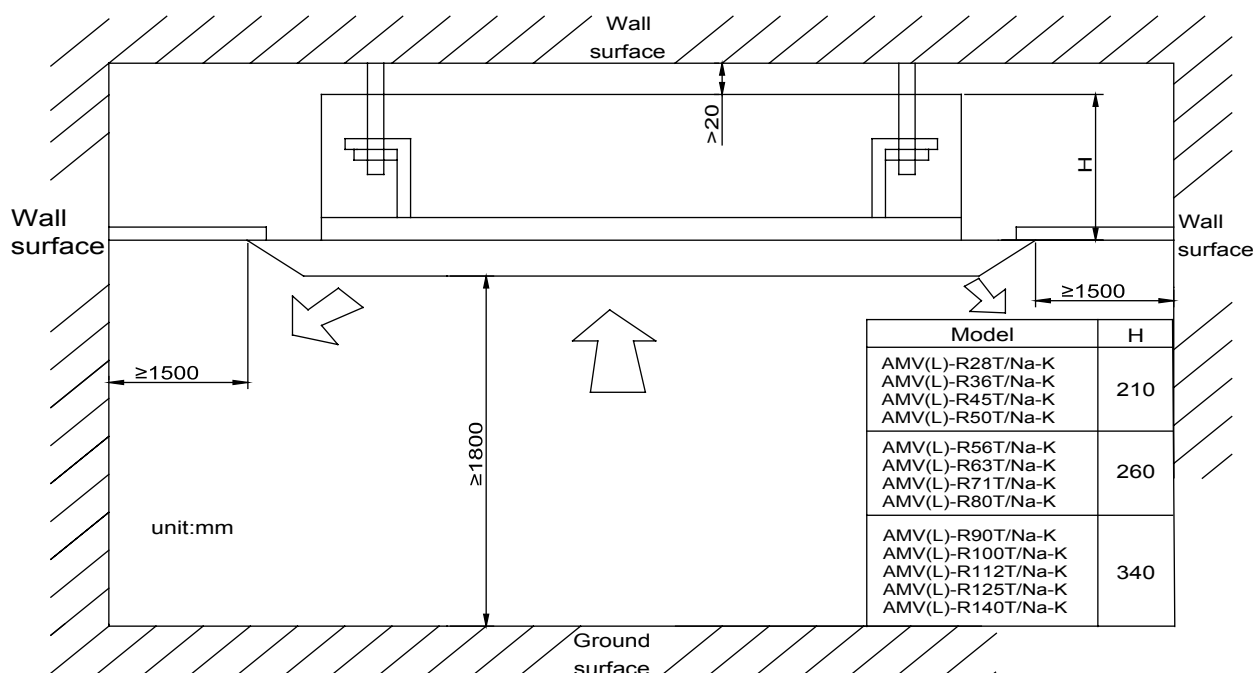

2.2 Selection of the Installation Location of the Indoor Unit

- (1). Obstruct should be put away from the intake or outlet vent of the indoor unit so that the airflow can be blown through all the room.
- (2). Make sure that the installation accords with the requirement of the schematic diagram of installation spaces.
- (3). Select the place where can stand 4 times of the weight of the indoor unit and will not increase the operating noise and vibration.
- (4). The installation place should be guaranteed to be horizontal.
- (5). Select the place where condensate water can easily be drained out and access to the outdoor unit.
- (6). Make sure that there is enough space for care and maintenance and the height between the indoor unit and ground is above 1800mm.
- (7). When installing the steeve bolt, check if the installation place can stand 4 times of the weight of the unit. If not, reinforce it before installation. (Refer to the installation cardboard and find where should be reinforced)

⚠ Note!

① . There will be lots of lampblack and dust stuck to the heat exchanger and water pump in the dining room and kitchen, which would reduce the capacity of the heat exchanger and lead water leakage and abnormal operation of the water pump. The following treatment should be taken under this circumstance:

② . Ensure that the smoke trap above the cooker is capable of preventing indraft of lampblack by the air conditioner.

③ . Keep the air conditioner far from the kitchen so that the lampblack would not be taken in by the air conditioner.

2.3 Important Notices

- (1). To guarantee the good performance, the unit shall be installed by professional personnel according to this instruction.
- (2). Please contact the local ASAMI nominated service center before installation. Any malfunction caused by the unit that is installed not by ASAMI nominated service center would not be dealt with on time owing to inconvenience of the business contact.

2.4 Dimension of the Ceiling Opening and Location of the Hoisting Screw (M10)

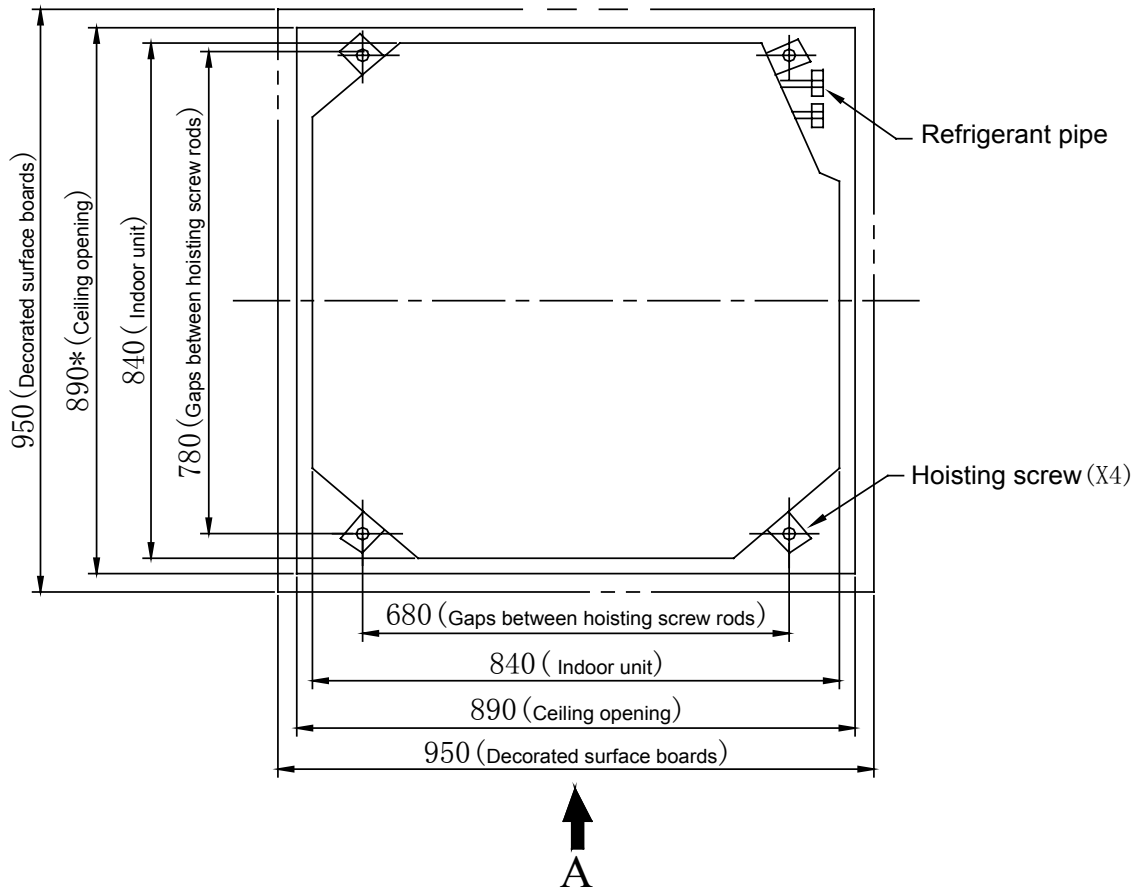

Fig. 1 Installation Dimensions

AMV(L)-R28T/ Na-K~AMV(L)-R140T/Na-K,

The drilling of holes in the ceiling must be done by the professional personnel.

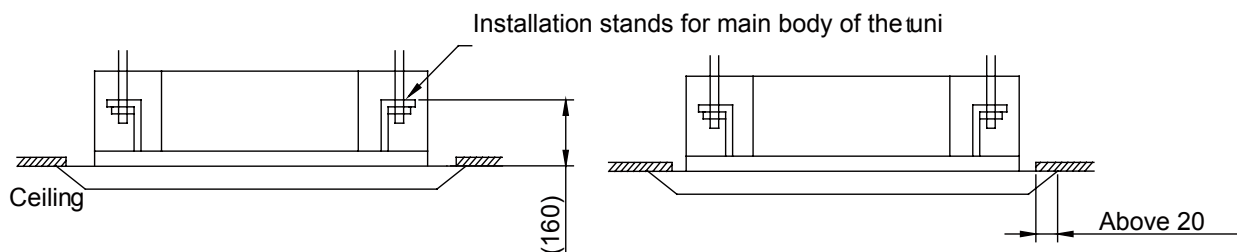

Fig. 2

⚠ Note! The dimension for the ceiling openings with * marks can be as large as 910mm, but the overlapping section of the ceiling and the decorated surface boards should be maintained no less than 20mm.

2.5 Main body for Hoisting the Air Conditioner

- (1). Primary Step for Installing the Indoor Unit
 - When attaching the hoisting stand on the hoisting screw, do use nuts and gaskets individually at the upper and lower of the hoisting stand to fix it. The use of the gasket anchor board can prevent the gasket from breaking off.
- (2). Use of the Installation Reference Cardboard
 - Please refer to the reference cardboard about the dimensions of the ceiling opening.
 - The center of the ceiling opening is marked on the reference cardboard.
 - Install the reference cardboard on the unit by bolts (3 pieces), and fix the corners of the drainage pipe at the outlet vent by bolts.
- (3). Adjust the unit to the suitable installation place. (Refer to Fig. 3)
- (4). Check if the unit is horizontal.
 - The inner drainage pump and the float switch are included in the indoor unit. Check if 4 corners of every unit are horizontal to water level. (If the unit is slant toward the opposite of the condensate water flow, the float switch may malfunction and may cause water drop.)
 - Backout the gasket anchor board used to prevent the gasket from breaking off and tighten the nut on it.
- (5). Backout the reference cardboard.

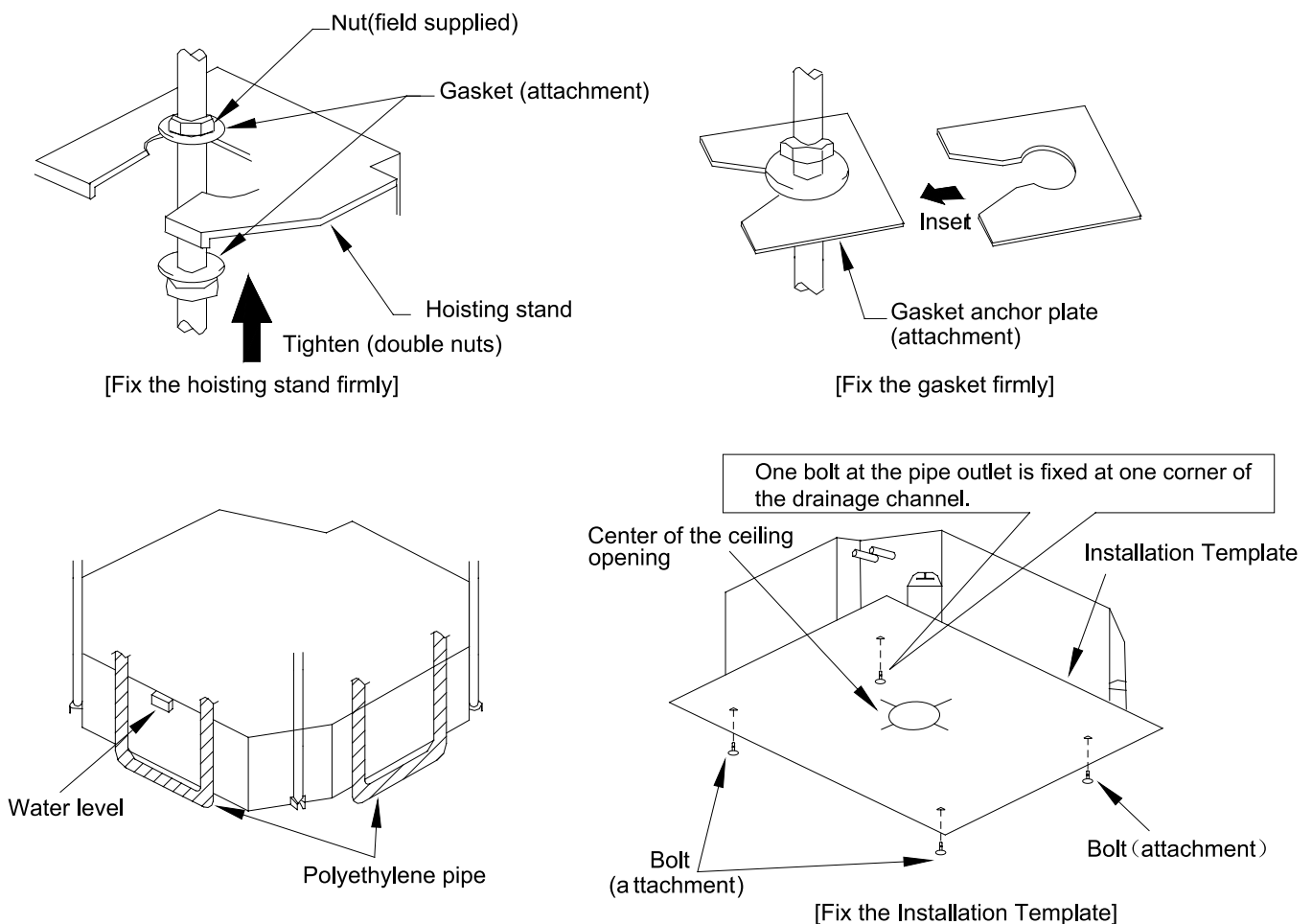

Fig.3

⚠ Note! Please do tighten the nuts and bolts to prevent the air conditioner break off.

2.6 Connection of the Refrigerant Pipe

- ◆ When connecting the pipe to the unit or backout it from the unit, please do use both the spanner and the torque wrench, as shown in Fig.4.
- ◆ When connecting, smear both inside and outside of the flare nut with refrigeration oil, screw it hand tight and then tighten it with the spanner.
- ◆ Refer to Table 1 to check if the wrench has been tightened properly (too tight would mangle the nut and lead to leakage).
- ◆ Examine the connection pipe to see if it leaks, then take the treatment of heat insulation, as shown in Fig. 4.
- ◆ Only use the medium-sized sponge to entwine the connector of the gas pipe and heat insulation sheath of the gas header.

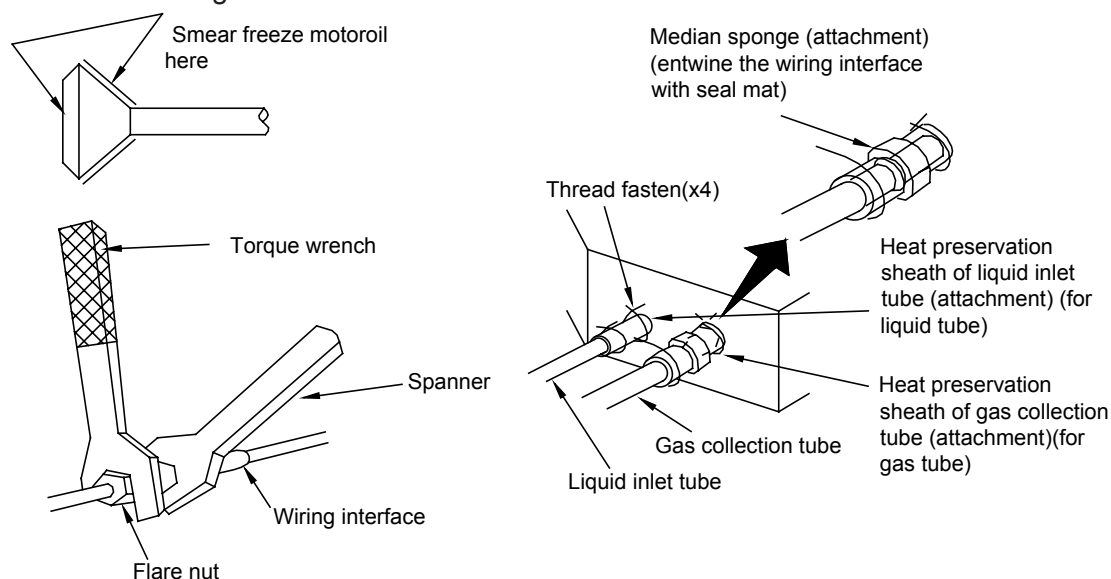

Fig. 4

Table 1: Tightening Torques Needed for Tightening Nut

Diameter(Inch)	Surface thickness(mm)	Tightening torque (N·m)
φ1/4"	≥0.5	15-30 (N·m)
φ3/8"	≥0.71	30-40 (N·m)
φ1/2"	≥1	45-50 (N·m)
φ5/8"	≥1	60-65 (N·m)
φ3/4"	≥1	70-75 (N·m)

2.7 Drainage Hose

- ◆ The diameter of the drain hose should be equal or larger than the connection pipe's. (polythene pipe: outer diameter 25mm; surface thickness ≥1.5mm)
- ◆ The drain hose should be as short as possible and should slant downward at a minimum gradient of 1/100 to prevent formation of air pockets.
- ◆ If the gradient of the drain hose is too small, a raising pipe should be added.
- ◆ To prevent the drain hose from bending, the distance between the hoisting stands should be 1 to 1.5m.

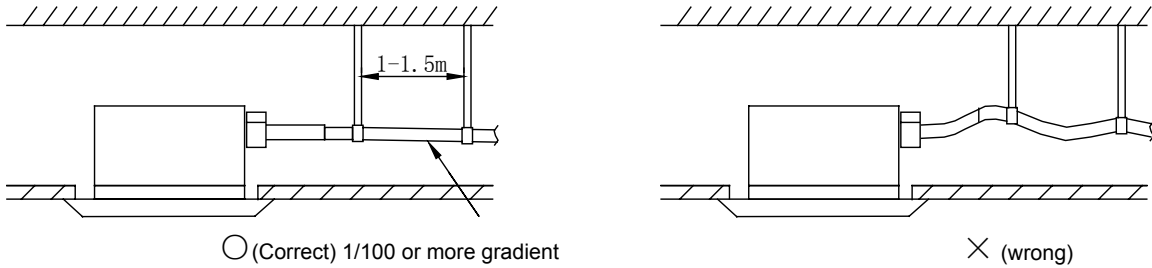

Fig. 5

- ◆ Insert the drain hose to the drain outlet and then tighten the clamp attached.
- ◆ Entwine the large-sized sponge on the clamp of the drain hose for heat insulation.
- ◆ Heat insulation should be done to the indoor drain hose.

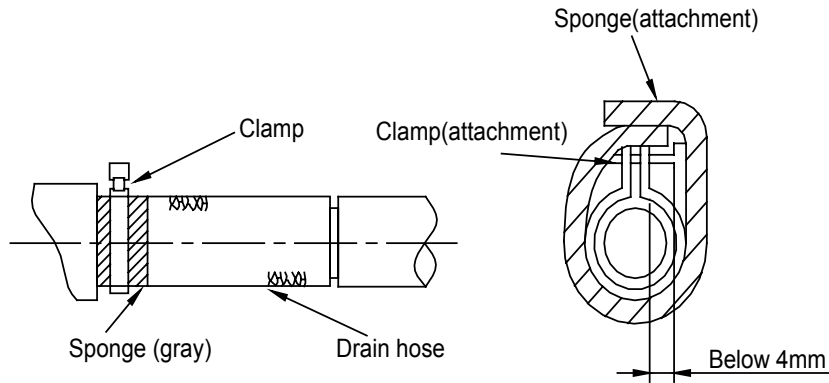
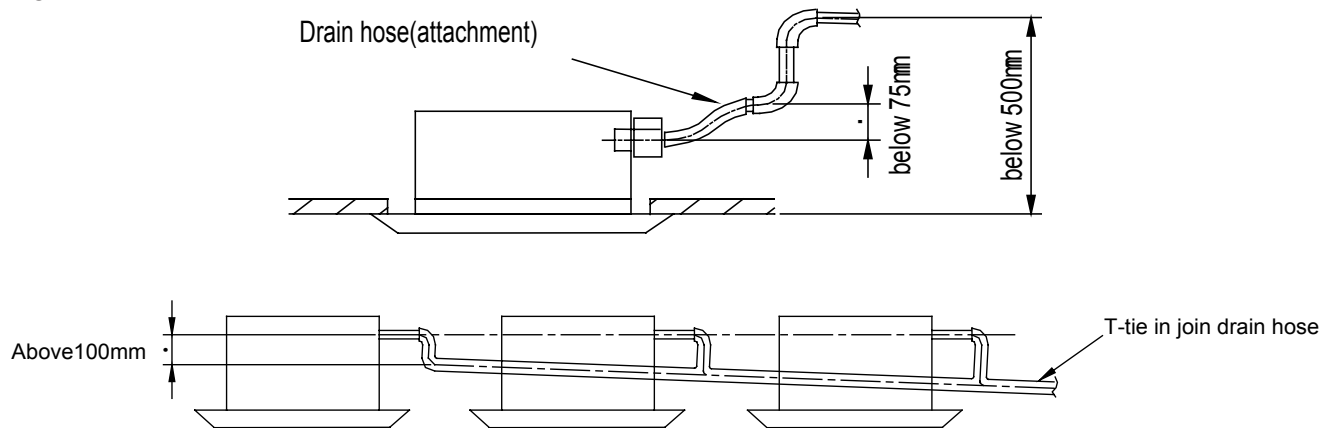

Fig. 6

- ◆ The slant gradient of the attached drain hose should be within 75mm so that the drain hole won't have to endure the unnecessary outside force.
- ◆ Please install the drain hose according to the following process if several drain hoses join together.



The specs of the selected join drain hose should fits the running capacity of the unit.

Fig. 7

2.8 Drain Raising Pipe

- ◆ The installation height of the raising pipe should be less than 280mm.
- ◆ The drain raising pipe should form a right angle with the unit, and distance to unit should not be larger than 300mm.

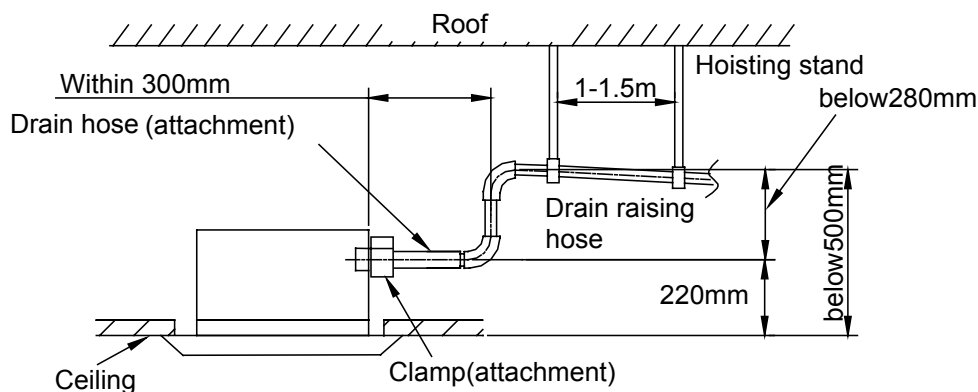

Fig. 8

2.9 Drainage Check

Check the smoothness of drainage after installation.

- ◆ Check the drainage state by injecting 600cc water slowly from the outlet vent or test hole.
- ◆ After electric wiring, check the drainage state when the unit is performing cooling.

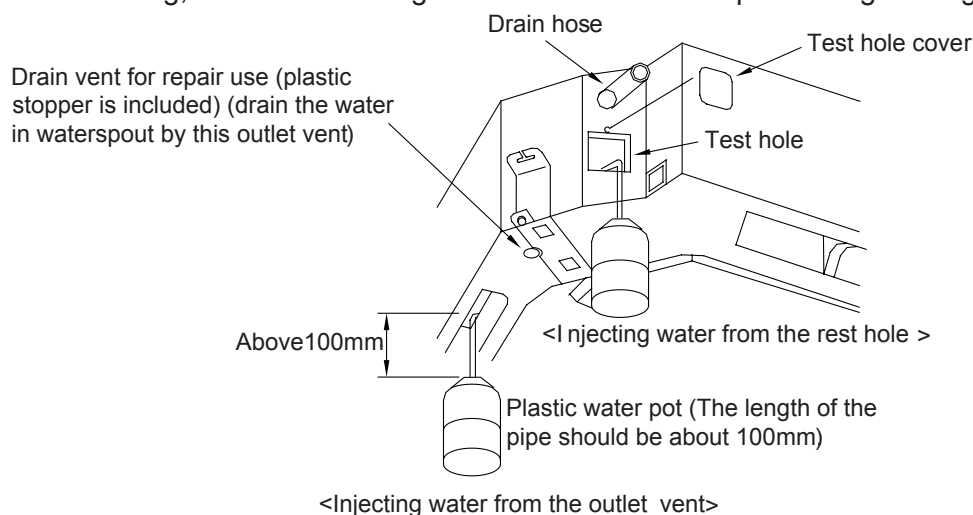

Fig. 9

2.10 Electrical Wiring

⚠ Note! The entire indoor unit shall have the uniform power supply.

- ◆ About the electrical wiring, please see the circuit diagram attached to the unit.
- ◆ All electrical wiring shall be done by professional personnel.
- ◆ Please do take the earthing treatment.

Wiring method of the unit and the controller

- ◆ Connection wiring (communication):

(1). Open the electric box cover(1), drag the wiring (communication) from the rubber plug A, and secure them well individually by fasteners.

(2). Wiring according to the indoor side circuit diagram.

- ◆ Fix the fasteners after connection.
- ◆ Wrap the small-sized sponge on the electric wire (do entwine it to prevent condensation).
- ◆ Secure the electric wire by fasteners after connection and then fit them on the electric box (1) and (2).
- ◆ Connect the 3-wire rubber-covered cable to the corresponding terminal on the terminal board.

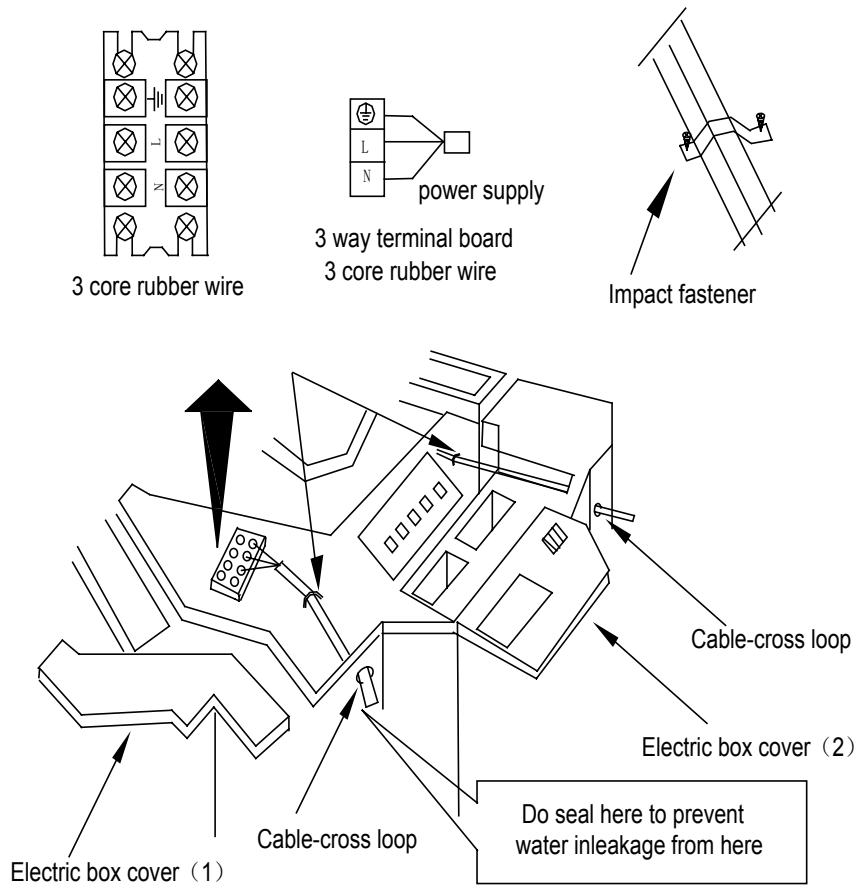

Fig. 10

2.11 Function Description of Functional DIP Switch S7

- (1). The 3-bit DIP switch must be set before the main board is energized and it determines the running state of the indoor unit.
- (2). DIP switch functions are described as below.

DIP Switch	Function	ON	OFF
1(S/R)	Selection of the memory mode: ① . Selection between reset mode and standby mode after energizing ② . This function is available without the wired controller.	Standby	Restore
2(L/I)	Selection between the wired controller and the receiver ① . If the wired controller is selected, the remote control function of the receiver will be disabled. ② . If the receiver is selected, the wired controller will be deactivated.	Wired Controller	Receiver
3(M/S)	Setting of the master and slave indoor units ① . Resolution for the conflict among the modes. ② . This function is available without the wired controller.	Master Indoor Unit	Slave Indoor Unit

2.12 Installation of the Panel

- (1). Set the panel to the indoor unit body by matching the position of the swing flap motor of the panel to the piping position of the panel of the indoor unit as shown in Fig. 11.
- (2). Installation of the Panel
 - 1). Install the panel on the indoor unit temporarily. When installing, hang the latch on the hook that is located on the opposite side of the swing flap on the panel of the indoor unit. (2 positions)
 - 2). Hang the remaining 2 latches to the hooks on the sides of the indoor unit. (Be careful not to let the swing motor lead wire get caught in the sealing material.)
 - 3). Screw the 4 hexagon head screws under the latches inward by about 15mm. (The panel would rise)
 - 4). Adjust the panel by turning it toward the direction pointed by the arrow as shown in Fig. 11 so that the panel can match the ceiling very well.
 - 5). Tighten the screws until the thickness of the sealing material between the panel and the indoor unit is reduced to 5-8mm.

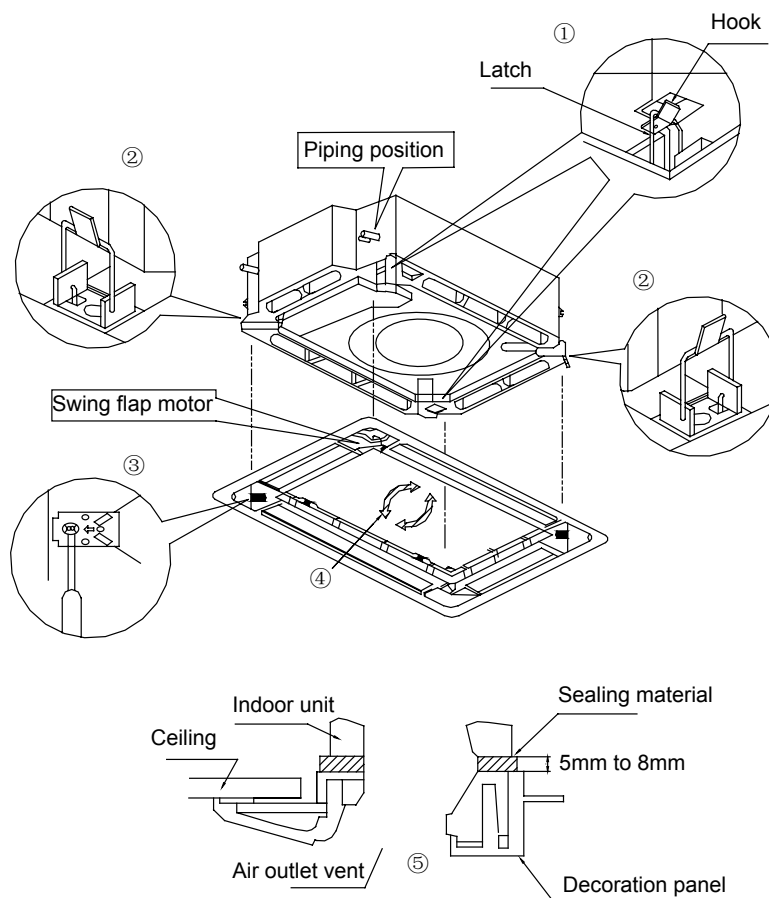

Fig. 11

⚠ Note!

- ① . Improper screwing of the screws may cause the troubles shown in Fig. 12.

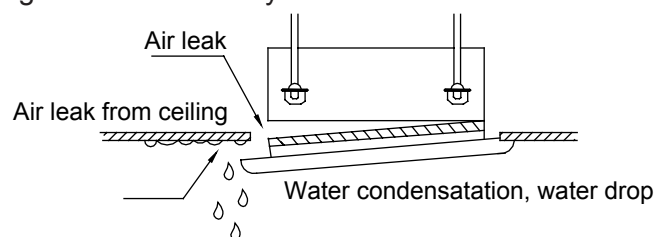

Fig. 12

- ② . If the gap still exists between the ceiling and the decoration panel after tightening the screws, readjust the height of the indoor unit. (As shown in Fig. 13)

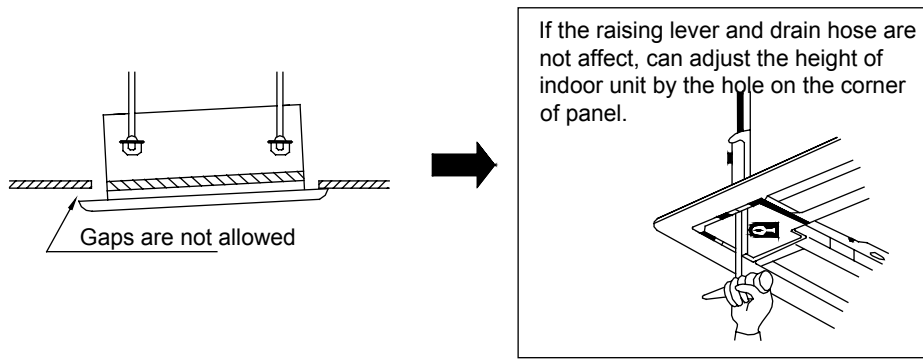

Fig. 13

③ . After fixing, be sure no gap left between the ceiling and the panel.

(3). Wiring of the Decoration Panel (Fig. 14)

◆ Connect the joints for the swing flap motor lead wire (at 2 places) installed on the panel.

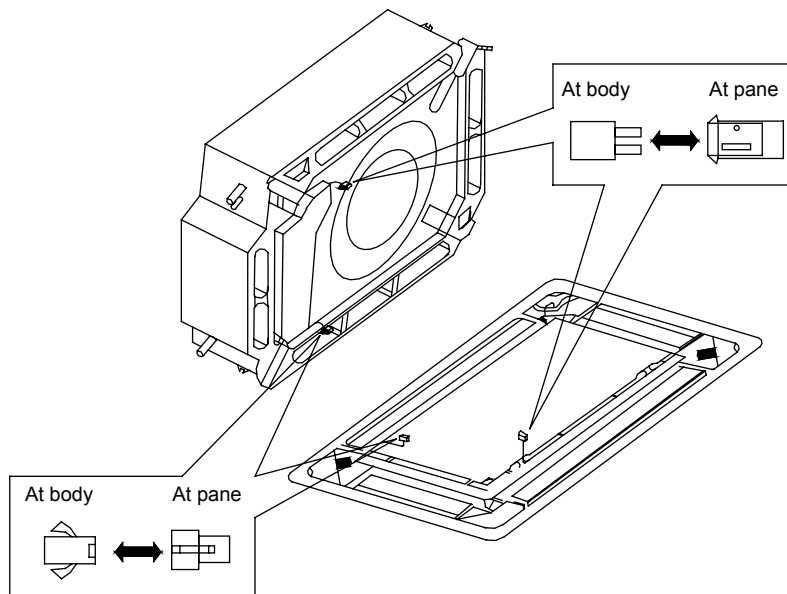
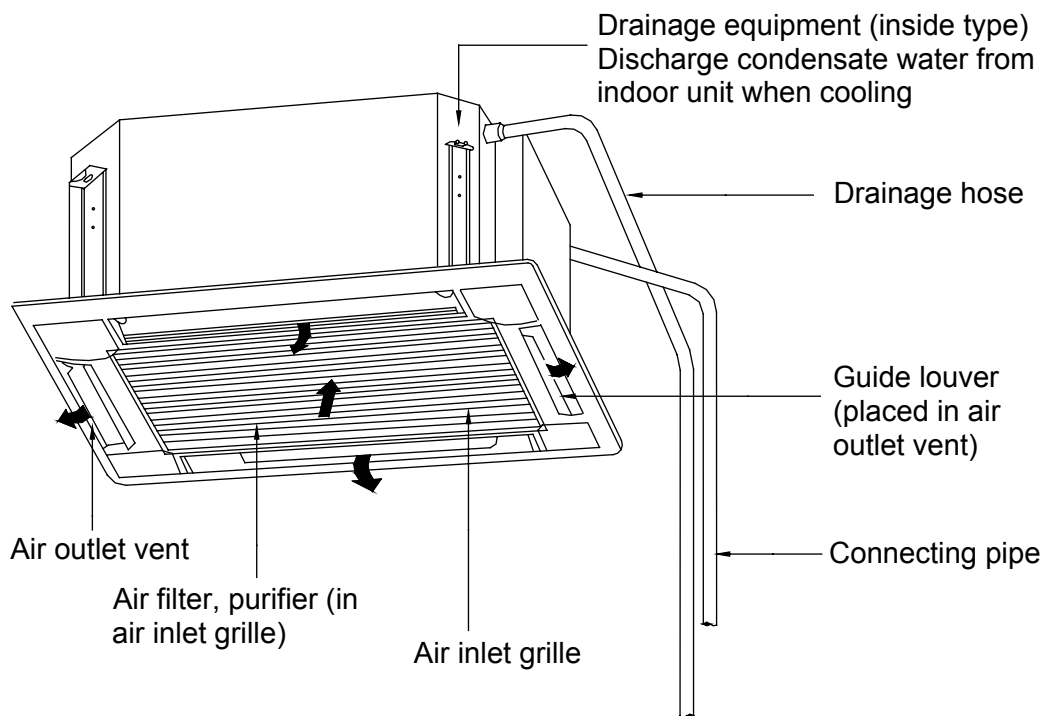

Fig. 14

3 Structure and Part Name of the Cassette Type Indoor Unit



AMV-R28T/Na-K	AMVL-R28T/ Na-K	AMV-R36T/Na-K	AMVL-R36T/ Na-K
AMV-R45T/Na-K	AMVL-R45T/ Na-K	AMV-R50T/Na-K	AMVL-R50T/ Na-K
AMV-R56T/Na-K	AMVL-R56T/ Na-K	AMV-R63T/Na-K	AMVL-R63T/ Na-K
AMV-R71T/Na-K	AMVL-R71T/ Na-K	AMV-R80T/Na-K	AMVL-R80T/ Na-K
AMV-R90T/Na-K	AMVL-R90T/ Na-K	AMV-R100T/Na-K	AMVL-R100T/ Na-K
AMV-R112T/Na-K	AMVL-R112T/ Na-K	AMV-R125T/Na-K	AMVL-R125T/ Na-K
AMV-R140T/Na-K	AMVL-R140T/ Na-K		

4 Working Temperature Range

Working Temperature Range

	Indoor side state		Outdoor side state	
	Dry bulb temp. °C	Wet bulb temp. °C	Dry bulb temp. °C	Wet bulb temp. °C
Rated cooling	27	19	35	24
Max. cooling	32	23	43	26
Min. cooling	21	15	18	—
Rated heating	20	15	7	6
Max. heating	27	—	24	18
Min. heating	20	15	-15	-16

5 Wired Controller and Wireless Controller

5.1 Wired Controller

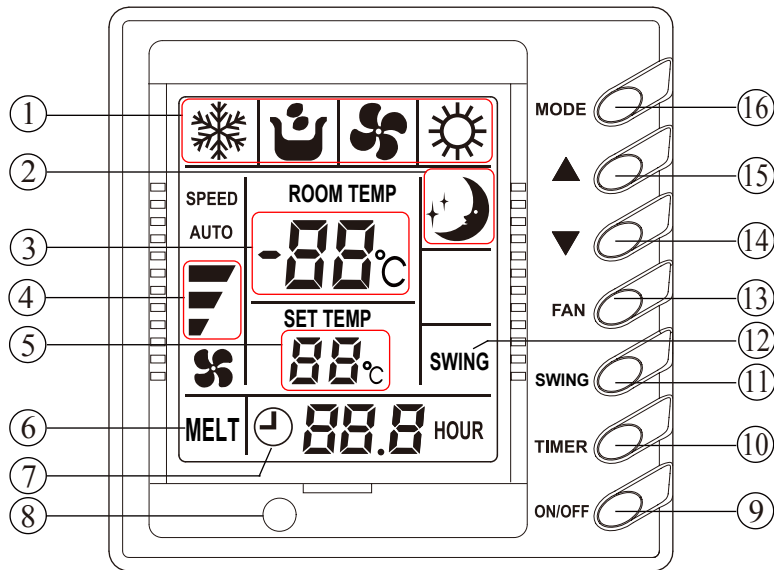

Fig. 15

Every Part of the Wired Controller			
1	Operating mode display (Cool, Dry, Fan, Heat)	9	On/Off button
2	Sleep mode display	10	Timer button
3	Environmental temp. display /Malfunction display	11	Swing button
4	Fan control display (automatic, high, medium, low)	12	Swing display
5	Set Temp. display	13	Fan control button
6	Defrosting display	14	Temp./ Timer decrease button
7	Timer display	15	Temp./ Timer increase button
8	Signal receiver	16	Mode button

◆ On/Off (Fig. 16)

- When pressing the ON/OFF button, the unit will start.
- When pressing the ON/OFF button again, the unit will stop.

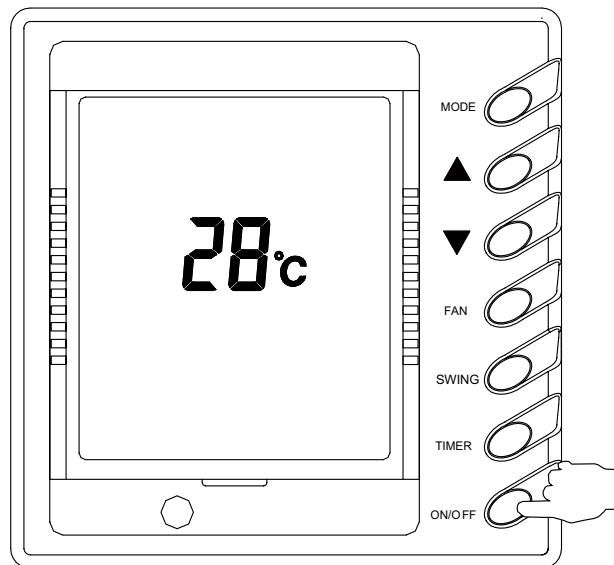

Fig. 16

⚠Note! The display in Fig. 16 is the turn-off state after the power supply is applied. When the power supply is applied and the communication is normal, the environmental temperature will be displayed on LCD no matter the unit is turned on or off. At this time, as shown in Fig. 3 there is no graticule displayed on LCD, which means that the air conditioner is turned off.

◆ Timer setting (Fig. 17):

- Press TIMER under the OFF state to set the ON time and press TIMER under the ON state to set the OFF time.

- Under the circumstance without the setting time (there isn't information in the Timer Zone), press TIMER, then the LCD will display the pattern of “⌚ xx.x HOUR”, and also the “⌚”and“HOUR”will keep blinking for 0.5 s, after that, press the button“▲”or“▼”to adjust the set time, next repress TIMER once more and the pattern“⌚”and “HOUR” will no longer blink, which indicates that TIMER has been set.

- Press TIMER once the unit is energized, and “⌚ 0.5 HOUR” will be displayed and both patterns will blink on the LCD, next, repress TIMER once again, then the TIMER pattern will disappear, which indicates that the TIMER setting has been cancelled.

- Under the circumstance that the TIMER time has been set (i.e. the state that “⌚”and“HOUR”don't blink), repress TIMER, then the “⌚ xx.x HOUR” will be displayed on the LCD again (note:“xx.x” indicates the set time last time, and will be cancelled after the controller is energized), and both “⌚”and “HOUR” will blink, at this time, adjust “▲”or“▼”to reset timer, or repress TIMER to confirm the TIMER setting.

- The TIMER setting ranges from 0.5-24 hours. Every single press of“▲”or“▼” will make the setting increased or decreased by 0.5 hour, and the long-term press will make the setting increased or decreased by 0.5 hour every 0.5 s, ranging from 0.5 to 24.

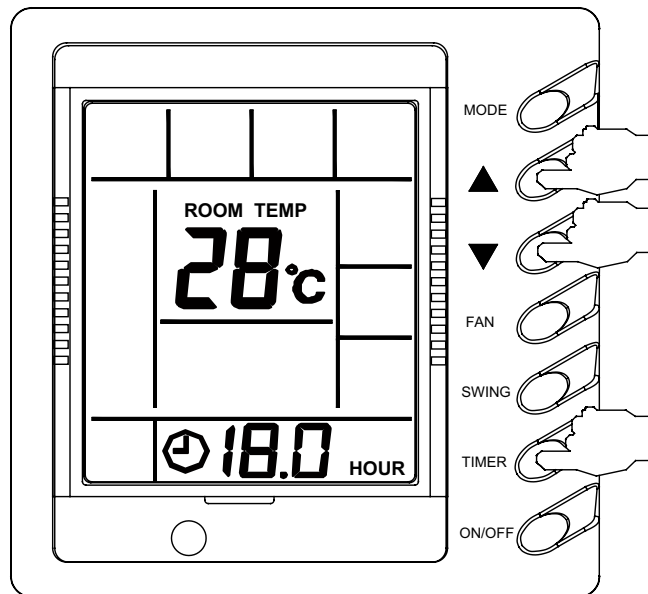
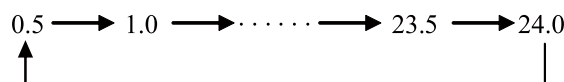
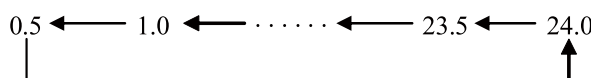

Fig. 17

◆ “▲”button



◆ “▼”button



◆ SLEEP Setting (Fig. 18)

- Under the COOL or DRY mode, after receiving the SLEEP order for 1 hour, the previous set temperature will rise by 1°C, and another 1°C after 2 hours, that is, the temperature rises by 2°C within 2 hours. Then the unit will run at this set temperature.

- Under the HEAT mode, after receiving the SLEEP order for 1 hour, the previous set temperature will drop by 1°C, and another 1°C after 2 hours, that is, the temperature drops by 2°C within 2 hours. Then the unit will run at this set temperature.

- There is no SLEEP mode under the FAN mode.

Note: The SLEEP button is not available for the wired controller. If required, this function should be performed through the wireless controller.

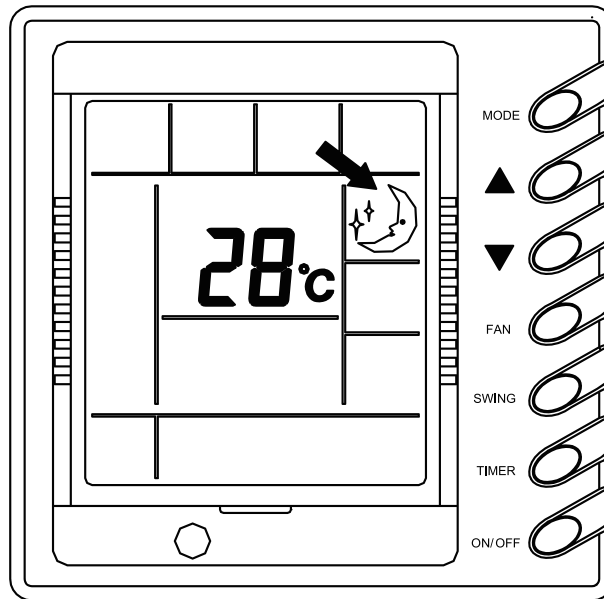

Fig. 18

◆ Swing Control(Fig. 19)

- Press the Swing button and then the swing mode will be operated by the air conditioner.

- Repress the Swing button once to stop the swing mode.

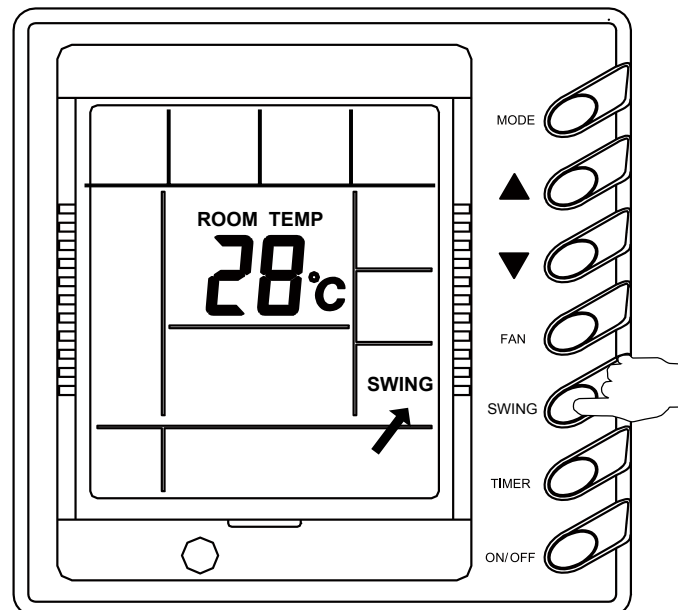
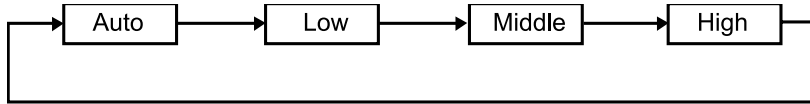

Fig. 19

⚠ Note! There is no swing mode for the duct type indoor unit

◆ Fan Speed Control(Fig. 20)

- Every press of the fan speed button will change the fan speed according to the following order:



- Under the DRY mode: The fan will be set to the low speed automatically.

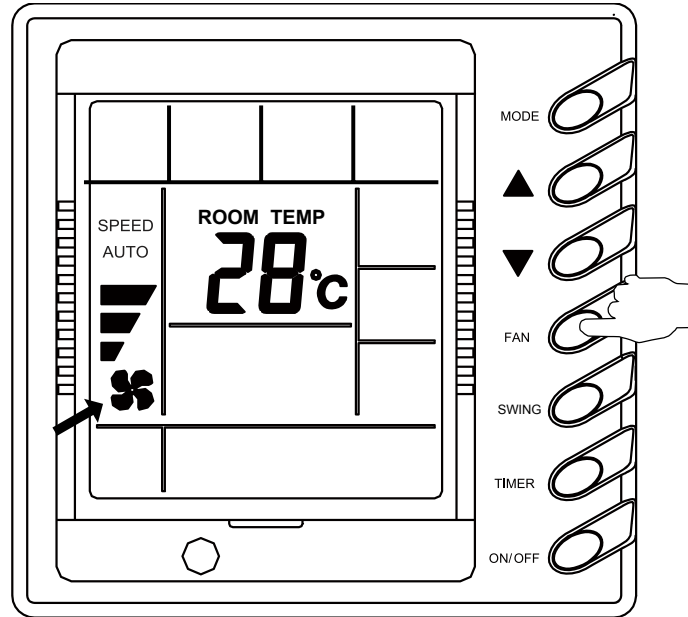

Fig. 20

◆ Temperature Adjustment (Fig. 21)

- Under the state without the time setting, press“▲”and“▼”to adjust the temperature.

▲:To rise the set temperature.

▼:To reduce set temperature.

(Every press of this button will increase or decrease the temperature by 1°C.)

- Temperature adjustment ranges 16°C~30°C under any running mode.

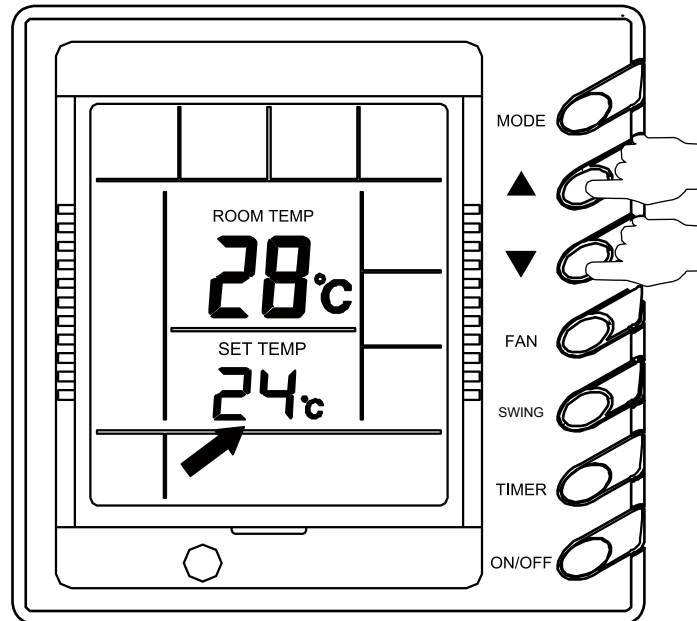

Fig. 21

◆ Setting of the Running Mode (Fig. 22)

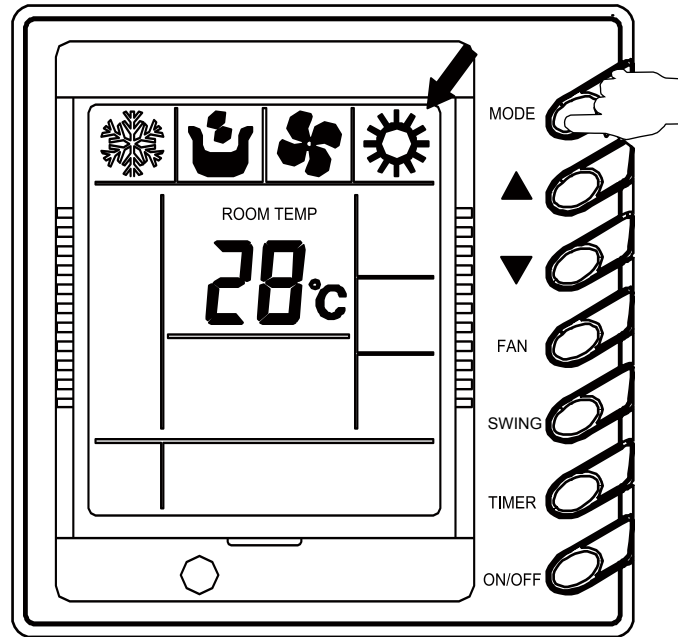
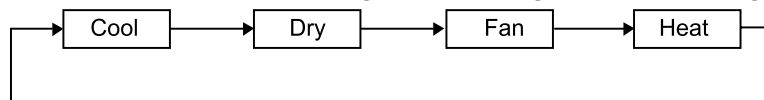

Fig. 22

- Every press of the Mode button will change the running mode according to the following order:



- Under the COOL mode, the display of the COOL icon will on. The set temperature should be lower than the present room temp. If not, the air conditioner would not perform cooling.

- Under the DRY mode, the display of the DRY icon will on. Fan will run at the low speed in some certain temperature range. The efficiency under this mode is better than that under the COOL mode and saves more energy.

- Under the HEAT mode, the display of the HEAT icon will on. The set temperature should be higher than the room; If not, the air conditioner would not perform heating.

- Under the FAN mode, the display of the FAN icon will on.

◆ Error Display (Fig.23)

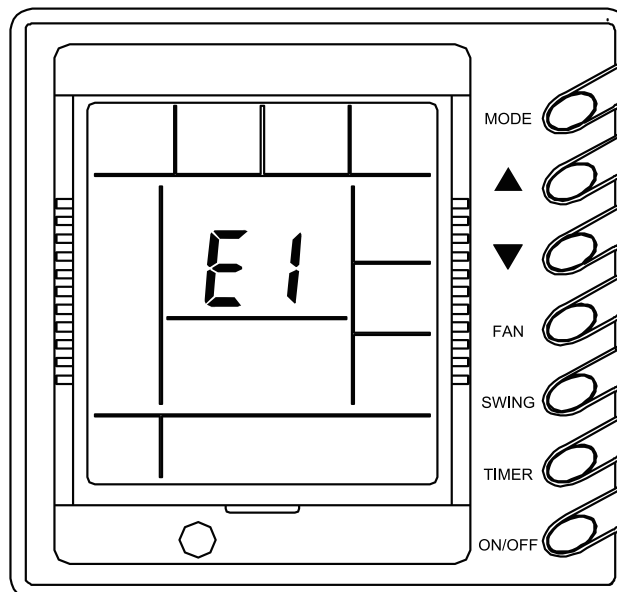

Fig. 23

- When some error happens, the error code will be shown in the environmental temperature display zone. Fig. 23 indicates that the compressor is under high pressure protection.
- Under the COOL, DRY and HEAT modes, if some error happens, the indoor unit will stop immediately; but it will run for another one minute under the FAN mode.
- When some error is displayed on the controller, please turn off the unit to stop and has it repaired by the specialized personnel.

The meaning of each error code is described

Error Code	Description
E1	High pressure protection of the compressor
E2	Indoor anti-freeze protection
E3	Low pressure protection of the compressor
E4	Discharge temperature protection of the compressor
E5	Compressor overload protection
E6	Communication error
E7	Modes conflict
E9	Full water protection
EH	Auxiliary electric heater error
F0	Indoor environment temperature sensor error
F1	Indoor coil inlet temperature sensor error
F2	Indoor coil mid-way temperature sensor error
F3	Indoor coil outlet temperature sensor error
F4	Outdoor environment temperature sensor error
F5	Outdoor coil inlet temperature sensor error
F6	Outdoor coil mid-way temperature sensor error
F7	Outdoor coil outlet temperature sensor error
F8	Discharge temperature sensor 1 (rated frequency) error
F9	Discharge temperature sensor 2 (digital) error
FA	Oil temperature sensor 1 (rated frequency) error
Fb	Oil temperature sensor 2 (digital) error
Fc	High pressure sensor error
Fd	Low pressure sensor error

5.2 Wireless Controller

⚠ CAUTION!

- ☆ Make sure there is no obstruction between the wireless controller and the signal receiver.
- ☆ The signal receiving distance of the wireless controller can be up to 10 metres.
- ☆ Never drop or throw the wireless controller randomly.
- ☆ Never let any liquid flow into the wireless controller.
- ☆ Never expose the wireless controller under the sunlight directly or where it is very hot.
- ☆ The wireless controller for the duct type indoor unit is an optional part.

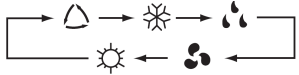













Fig. 24

5.2.1 Control Panel of the Wireless Controller

Table 6

Name	Function Description
ON/OFF button	<ul style="list-style-type: none"> ● Press this button, and the unit will be turned on; press it once more, and the unit will be turned off. When turning on or turning off the unit, the Timer, Sleep function will be canceled, but the presetting time is still remained.
- button	<ul style="list-style-type: none"> ● Preset temperature can be decreased by pressing this button. Continuous pressing this button for more than two seconds can make the temperature changed quickly until release this button and then transmit this order, in which case, °C (°F) will be displayed all the time. The temperature adjustment is unavailable under the Auto mode, but the order can be sent by pressing this button.

<p>+ button</p>	<ul style="list-style-type: none"> The preset temperature can be increased by pressing this button. Continuously pressing this button for more than 2 seconds can make the temperature changed quickly until release the button and then transmit this order, in which case, °C (°F) is displaying all the time. The temperature adjustment is unavailable under the Auto mode, but the order can be sent by pressing this button. Centigrade setting range: 16-30; Fahrenheit scale setting range 61-86.
<p>X-FAN button</p>	<ul style="list-style-type: none"> Pressing X-FAN button in COOL or DRY mode, the icon “☼” is displayed and the indoor fan will continue operation for 10 minutes in order to dry the indoor unit even though you have turned off the unit. After energization, X-FAN OFF is defaulted. X-FAN is not available in AUTO, FAN and HEAT mode.
<p>MODE button</p>	<ul style="list-style-type: none"> By pressing this button, Auto, Cool, Dry, Fan, Heat mode can be selected circularly. Auto mode is default after power on. Under the Auto mode, the temperature will not be displayed; Under the Heat mode, the initial value is 28 °C (82 °F); Under other modes, the initial value is 25 °C (77 °F).  <p>△ AUTO ; ☼ COOL; ☼ DRY; ☼ FAN; ☼ HEAT (only for cooling and heating unit)</p>
<p>SWING UP/ DOWN button</p>	<ul style="list-style-type: none"> Press this button to set up the swing angle, which circularly changes as below:  <p>This is a universal wireless controller. When it receives any of the swing control commands of ☼ the swing status keeps at ☼</p> <p>When the guide louver starts to swing up and down, if SWING functions is deactivated, the air guide louver will stop and remains at the current position.</p> <p>☼ indicates the guide louver swings up and down among those five directions.</p>
<p>FAN button</p>	<ul style="list-style-type: none"> By pressing this button, Auto, Low, Middle, High speed can be circularly selected. After power on, Auto fan speed is default. Under the Dry mode, the unit can only run at the low fan speed.  <p>▲ Low fan ▲▲ Middle fan ▲▲▲ High fan</p> <p>Note: Under the DRY mode, the fan will be kept running at the low speed even though the wireless control displays that the fan speed is changed.</p>

CLOCK button	<ul style="list-style-type: none"> By pressing this button, the clock is allowed to be set,  with blinking, and then press the +/- button to adjust the clock within 5 seconds. If the CLOCK button is pressed down constantly for more than 2 seconds, the clock setting will increase 10 minutes every 0.5 seconds. After that, another press on the CLOCK button will make the symbol  indicate the setting time and blink. 12:00 is the default when the wireless controller is energized with the symbol  indicating the current clock time.
TIMER ON button	<ul style="list-style-type: none"> When TIMER ON is activated, "ON" will blink while the symbol  will disappear. Within 5 seconds it is allowed to set the "ON time by pressing the +/- button. Each press will make the time increase or decrease one minute. Besides, the time can also be set by pressing the +/- button constantly. that is, in the early 2.5 seconds, the time will increase/decrease quickly per single minute, and in the late 2.5, the time will increase/decrease per ten minutes. After the desired time value is set, press TIMER ON again to conform the setting within five seconds. After that, another press on TIMER on will cancel the setting. Prior to this setting, the clock shall be set to the actual time.
TIMER OFF button	<ul style="list-style-type: none"> By pressing this button it is available to go to the TIMER OFF setting state with the same setting method as that of the TIMER ON, in which case the TIMER OFF symbol will blink.
TEMP button	<ul style="list-style-type: none"> By pressing this button it is allowed to select the temperature option, the indoor setting temperature or the indoor ambient temperature. However, when there is no any temperature symbol on the wireless control, the current temperature option will be kept unchanged. (Indoor setting temperature is default after the indoor unit is energized initially) By pressing the TEMP button, when the temperature symbol  is displayed, the wireless control will show the indoor setting temperature; when  is displayed, it will show the indoor ambient temperature; when  is displayed, it will keep the current temperature option.
TURBO button	<ul style="list-style-type: none"> In the Cool or Heat mode, pressing this button can activate or deactivate the TURBO function. When the TURBO function is activated, its symbol will be displayed; when the running mode or the fan speed is changed, this function will be canceled automatically.
SLEEP button	<ul style="list-style-type: none"> By pressing this button, Sleep On and Sleep Off can be selected. After powered on, Sleep Off is defaulted. Once the unit is turned off, the Sleep function is canceled. When Sleep is set to On, the symbol of SLEEP will display. In this mode, the time of timer can be adjusted. Under the Fan and Auto modes, this function is not available.
LIGHT button	<ul style="list-style-type: none"> Press this button to select LIGHT on or off. When the LIGHT is set to on, the icon  will be displayed and the indicating LED in the display will light up. When the LIGHT is set to off, the icon  will be displayed and the indicating LED in the display will light off.

5.2.2 Introduction to Special Functions

☆ About X-FAN function

This function indicates that the indoor fan will continue its operation for another 10 minutes after the unit is turned off in order to dry the evaporator of the indoor unit.

① . Having set X-FAN function on: After turning off the unit by pressing ON/OFF button indoor fan will continue running for about 10 min. at low speed. In this period, press X-FAN button to stop indoor fan directly.

② . Having set X-FAN function off: After turning off the unit by pressing ON/OFF button, the complete unit will be off directly.

☆ About TURBO function

If the TURBO function is activated, the unit will run at high fan speed to perform cooling or heating quickly so that the ambient temperature will approach the preset temperature as soon as possible.

☆ About After-Heat Elimination (This function is applicable to some special models)

When the air conditioner is turned off under the Heat or Auto mode, the compressor and outdoor fan will stop running directly and the upper and lower guide board rotate to the horizontal position, while the indoor fan will run for another 10 seconds at the low speed and then stop.

☆ About LOCK

Press + and - buttons simultaneously to lock or unlock the keyboard. If the wireless controller is locked, the icon  will be displayed on it, in which case, any press will get no response but with the mark blinking for three times. If the keyboard is unlocked, the mark will disappear.

☆ About SWING UP/DOWN

① . Press the Swing Up/Down button  for more than 2 seconds and then the louvre will swing up and down. After releasing the button, the louvre will stop swinging and keep the current status.

② . When the louvre starts swinging, by pressing the Swing Up/Down button 2 seconds later, the louvre will stop swinging directly; while, by pressing the Swing Up/Down button within 2 seconds, the louver will keep swinging.

☆ About Changeover between Fahrenheit and Centigrade

Under the OFF state of the unit, press MODE and - buttons simultaneously to switch between °C and °F .

5.2.3 Replacement of Batteries

- (1). Slightly press the place with  along the arrowhead direction and push the back cover of the wireless remote controller. (As shown in the figure)
- (2). Take out the used batteries. (As shown in the figure)
- (3). Insert two new AAA 1.5V dry cell batteries and pay attention to their polarity. (As shown in the figure)
- (4). Put back the cover of the wireless remote controller. (As shown in the figure)

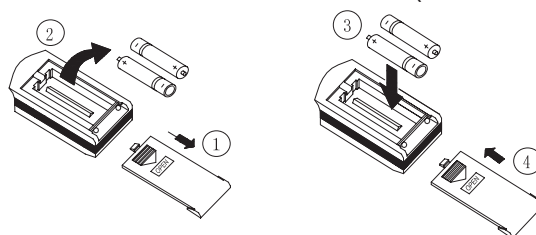

Fig. 25

Note!

- ① . When changing the batteries, do not use the used or different-type batteries, otherwise, it would cause some malfunction of the wireless remote control.
- ② . If the wireless remote control is not to be used for a long period, please take them out, and don't let the battery liquid damage the wireless remote control.
- ③ . The operation should be within the signal receiving range.
- ④ . It should be placed 1m away from the TV set or stereo sound sets.
- ⑤ . If the wireless remote control can not operate normally, please take them out, after 30s later and reinsert them, if the anomaly persists, please change them.

6 Operation Method in Case of Emergency

When the Wireless controller is lost or damaged, the following method could be adopted to control the cassette type indoor unit:

◆ When the unit is turned off, press the AUTO button on corner outer cover II, then the unit begin operate in cooling with the fan run in high speed. The temp. will be set to 26°C automatically.

◆ When the unit is turned off, press the TEST button on the corner outer coverII, then the unit begin running in heating and the fan is running in high speed. The temp. will be set to 20°C automatically.

◆ When the unit is running, press the AUTO button on corner outer cover II, then the unit stops running; under the running state of heating, press TEST button on corner outer cover II, then the unit stops running.

Note!

Prevent using the operating method for meeting an emergency when the Wireless controller could be used in normal. There are 3 lights on corner outer cover II, red for power, green for running, and yellow for timer.

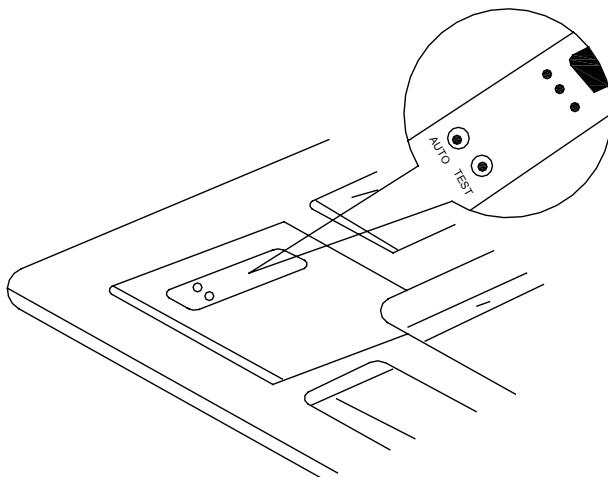

7 Troubleshooting

Warning!

• When some malfunction happens (such as burning odor etc.), please switch off the main power switch immediately and then contact the service center. If the abnormal state continues, the unit may be damaged or electric shock or fire may happen.

• Do not refit the conditioner. In any case, please contact the service center to repair or move the conditioner.

• Check the following items before contacting the service center.

Phenomena	Causes	Remedial Measures
Air conditioner doesn't run at all	The fuse or breaker is broken	Change the fuse or close the breaker
	Power failure	Restart when power supply is restored
	Power supply does not connect through	Connect the power well
	Low-voltage batteries	Replace the batteries
	The Wireless controller is beyond the remote control range.	The controller should be put within the control range
Air conditioner starts but then stops immediately	Blockage in the inlet or outlet vent of the indoor or outdoor unit	Clean away the blockage
Abnormal cooling or heating	Blockage in the inlet or outlet vent of the indoor or outdoor unit	Clean away the blockage
	Improper temperature setting	Adjust the settings in Wireless controller
	Low fan speed	Adjust the settings in Wireless controller
	Incorrect wind direction	Adjust the settings in Wireless controller
	Door or window opened	Close the door or window
	Direct sunlight	Hang the curtain or jalousie before windows
	Too many people in the room	
	Too many heat source in the room	
	This filter is blocked by dirt	Clean the filter

If it still fails to find out where the problem is, please contact the service center and inform the phenomena and unit model.

Cassette Type Indoor Unit

- The following circumstances can not be considered to be malfunctions.

Malfunction		Causes
The air conditioner doesn't run	Start the unit soon after it is turned off	The overload protection switch acts and the restart is 3 minutes delayed.
Mist is blown out from the air conditioner	When cooling	The high humidity air in the room is cooled rapidly
Noise is generated	Slight click sound once the unit begins running	It is caused during the initialization of the electronic expansion valve.
	Continuous hissing sound when cooling	It is caused when the gas refrigerant is flowing in the unit
	Hissing sound when starting or stopping the unit	It is caused when the gas refrigerant flow stops
	Slight hissing sound when the unit is running after running	It is caused when the drainage system is running.
	Creak sound when the unit is running or after running	It is caused by expansion of the panel and other parts owing to temperature change.
Dust is blown out from the air conditioner	Restart the unit when it has not run for a long time.	Dust in the indoor unit is blown out.
Odor gives out from the air conditioner	When running	Odors or cigarette smoke once sucked in is discharged out again.

- After-sales Service

When quality or other problems are raised upon the purchased air conditioner, please contact the local service center.

8 Maintenance

When the air conditioner is not to be used for long time, please cut off the main power supply to the air conditioner.

Warning!

①. Do not turn off the unit and cut off the main power supply when cleaning the air conditioner, otherwise electric shock or harm may happen.

②. It is forbidden to wash the air conditioner by water rinsing, otherwise electric shock may happen.

◆ Cleaning the Air Filter

When the usage environment has lots of dust, the air filter should be cleaned more frequently (about once every 6 months).

(1). Opening the Air Inlet Grille

Pull the 2 handle on air inlet grille at the same time with the direction showed by arrow in fig.26, pull down slowly. (Reverse when closing)

(2). Disassembling the Air Filter

As shown in Fig.27, pull the handle behind the air inlet grille, raise and disassemble it, and then remove 3 purifiers fixed on the filter.

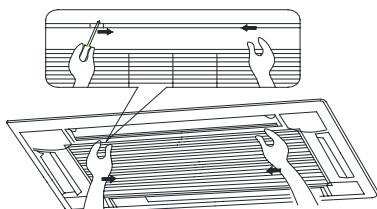

Fig. 26

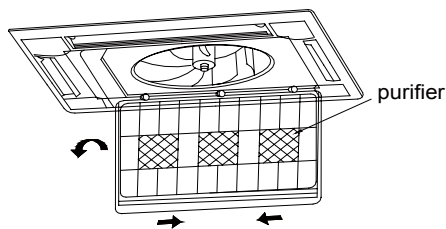

Fig. 27

(3). Cleaning

User cleaner or water to wash the filter. If the filter is too dirty (like there is oil stain on it), use warm water (lower than 45°C) with the neutral cleaner to clean it, then dry it in the shade.

⚠ Note!

① .Do not clean the filter by hot water whose temperature is higher than 45°C to prevent fade or deformation.

② .Do not burn it on fire, otherwise the filter would catches fire or deformation.

(4). Installing the Air Filter

Fix those 3 purifiers on the filter, install the filter on the several bulges on top of the air inlet grille, and pull the handle behind the air inlet grille toward inside to fix the filter, as shown in Fig.28.

(5). Closing the Air Inlet Grille (Refer to step 1)

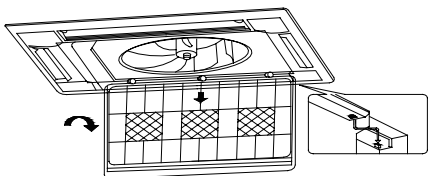

Fig. 28

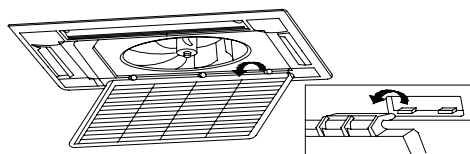

Fig. 29

◆ Cleaning the Air Inlet Grille

(1). Open the air inlet grille (the same with the 1st step of Clean Air Filter)

(2). Take out the air filter (the same with the 2nd step of Clean Air Filter)

(3). Take out the air inlet grille

(4). Open the air inlet grille for an angle of 45°, as shown in Fig.29, and then raise it.

(5). Clean it through a soft brush, water and neutral cleanser, and hen dry it.

⚠ Note! Do not use water above 45°C to wash the panel to prevent fade or deformation.

(6). Install the air inlet grille (refer to 3rd step)

(7). Install the air filter (refer to the 4th step of Clean Air Filter)

(8). Close the air inlet grille (refer to the 1st step)

◆ Installing and Replacing the Air Purifier

(1). Open the air inlet grille (the same the 1st step of Clean Air Filter)

(2). Disassemble the purifier

As shown in Fig.30, disassemble the air filter, screw out the fixing bolts fixed on the purifier on the filter, and finally the purifier can be disassembled.

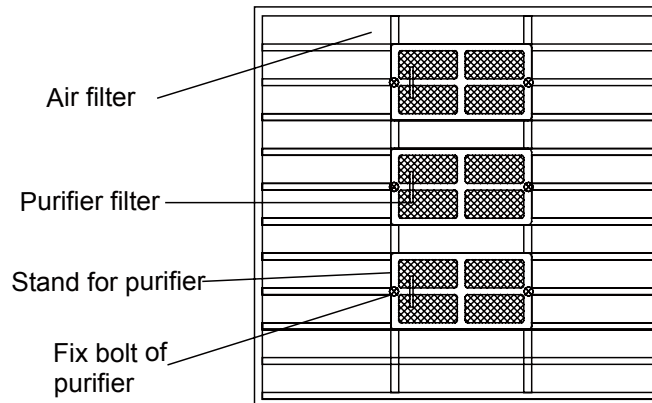

Fig. 30

- (3). Take out the package sack of the static fiber net filter, next install the filter in place of the purifier, and then fix the purifier on the air filter.
- (4). Install air filter (the same with the 4th step of Clean Air Filter).

Function and Usage Period for the Air Purifier

- Capable of adsorbing CO, CO₂, benzene, aldehydes and odor of gasoline etc..
- Capable of adsorbing deleterious material that is smaller than 1μm in air, like dust, pollen, bacteria, and virus.
- Service life is 6 months to 1 year. If it is necessary to be replaced, purchase a new purifier in the nearest ASAMI service center.

Cleaning the Outlet Vent and the Surface Panel

- Clean the surface panel by soft dry cloth or wet cloth with neutral cleaner.
- It is forbidden to clean the surface panel by gasoline, benzene, thinner, cleansing powder etc..
- If the guide louver is too dirty, it needs to be removed for cleaning. (As described below)

◆ Disassemble and install the guide louver

(1). Disassembling the Guide Louver

Unscrew bolts in both ends of the guide louver.

⚠ **Note!**

Do not wipe the guide louver forcibly when cleaning, otherwise fluff on the surface would fall off.

(2). Installing the Guide Louver

Rotate guide louver slightly could install the protruding edge of both end into grooves on both end of guide louver, and then tighten bolts.

◆ Maintenance before or after the Usage Season

Check before the Usage Season

- Check if there is blockage in the inlet or outlet vent of the air conditioner.
- Check if the earthing wire has been earthed reliably.
- Check if the air filter has been installed well.
- In order to start up the air conditioner smoothly after long time's turned off, energize the unit 8 hours before turning it on.

Maintenance after the Usage Season

- Clean the filter and the body of the air conditioner.
- Cut off the main power supply of the air conditioner.



66129911519