



Owner's Manual

Original Instructions

Modbus Gateway(Pro)

Models:ME30-24/E5(M)

To Users

Thank you for selecting Gree's product. Please read this instruction manual carefully before installing and using the product, so as to master and correctly use the product. In order to guide you to correctly install and use our product and achieve expected operating effect, we hereby instruct as below:



- (1) This appliance is not intended for use by persons (including children) with reduced physical, sensory or mental capabilities, or lack of experience and knowledge, unless they have been given supervision or instruction concerning use of the appliance by a person responsible for their safety. Children should be supervised to ensure that they do not play with the appliance.
- (2) This instruction manual is a universal manual, some functions are only applicable to particular product. All the illustrations and information in the instruction manual are only for reference, and control interface should be subject to actual operation.
- (3) In order to make the product better, we will continuously conduct improvement and innovation. We have the right to make necessary revision to the product from time to time due to the reason of sales or production, and reserve the right to revise the contents without further notice.
- (4) For personal injury or property loss and damage caused by improper operation such as improper installation and debugging, unnecessary maintenance, violation of related national laws and rules and industrial standard, and violation of this instruction manual, etc., we will bear no liability.
- (5) The final right to interpret for this instruction manual belongs to Gree Electric Appliances Inc. of Zhuhai.



User Notice

Dear customer:

Please read this manual carefully prior to installation and operation and strictly observe all installation and operation instructions covered in the manual.

Special attentions shall be paid to the following marks:

 WARNING!	This mark indicates operation, which if improperly performed, might lead to the death or serious injury of the users.
 Notice!	This mark indicates operation, which if improperly performed, might possibly result in damage to the device.

 WARNING!	
(1)	Installation shall be performed by the qualified personnel; otherwise it would result in a fire hazard or electric shock.
(2)	Do not place the plug of the power supply into the socket before it is dried and cleaned.
(3)	Cut off the power supply before touching the electric element.
(4)	Do not touch this device with wet hands; otherwise it would result in electric shock.
(5)	Do use the power cable specified in this manual; otherwise it would result in a fire hazard.
(6)	When the power cable is reversely connected or the power supply is beyond the rated range, it would result in a fire hazard or even damages to this device.
(7)	Do install this device inside the electric control cabinet which is located indoor and then is locked.
(8)	Do install this device where it will not be subject to the electromagnetic interference or heavy dust.
 Notice!	
(1)	Be sure the specified adaptor is used; otherwise this device would work improperly or even be damaged.
(2)	Be sure this device is setup in place; otherwise it would result in communication fault.
(3)	Be sure the communication line is connected to the correct interface; otherwise it would result in communication fault.

(4) After connection, lines should be protected with insulating tape to avoid oxidation and short circuits.

(5) Normal working conditions for Modbus Gateway(Pro):

① Temperature : -20~+60℃;

② Humidity: less than 85%

③ Location: indoor (it is highly recommended to install this product in the electric control cabinet), not subject to direct sunlight, rain and snow etc.

(6) Graphics in the instruction manual are for reference only.

Contents

1 Safety Notices (Please be sure to abide)	1
2 Function	1
2.1 General Functions	1
3 Composition	2
4 Detailed Instruction of Modbus Gateway(Pro)	3
4.1 Interfaces	3
4.2 LED display.....	6
4.3 DIP Switches	6
5 Application.....	10
5.1 Building Management System (BMS)	10
5.2 Internet topological graph.....	11
5.3 Topology Introduction:	11
6 Installation	12
6.1 Product Dimension and Installation Space of Electric Control Cabinet	12
6.2 Communication Connection	13
7 Annex: DIP Address	19

1 Safety Notices (Please be sure to abide)



Warning: If not abide strictly, it may cause severe damage to the unit or the people.



Note: If not abide strictly, it may cause slight or medium damage to the unit or the people.



This sign indicates that the operation must be prohibited. Improper operation may cause severe damage or death to people.



This sign indicates that the items must be observed. Improper operation may cause damage to people or property.



WARNING!

This product can't be installed at corrosive , inflammable or explosive environment or the place with special requirements, such as kitchen. Otherwise, it will affect the normal operation or shorten the service life of the unit, or even cause fire hazard or serious injury. As for above special places, please adopt special air conditioner with anti-corrosive or anti-explosion function .

2 Function

2.1 General Functions

Gree Modbus Gateway(Pro) are intended to realize the data exchange between the air conditioner and BMS, and provides ten I/Os (five inputs are DI1, DI2, DI3, DI4, DI5 and five outputs are DO1, DO2, DO3, DO4, DO5). DI1 is the fire alarm interface. The status of other I/Os is mapped to the specific objects of the Modbus bus and is defined by the user. This gateway is applicable for Gree multi VRF system which adopts CAN protocol.



3 Composition

The product contains following items. Please check them prior to installation.

Modbus Gateway(Pro)	1 set
Owner' s Manual	1 set

4 Detailed Instruction of Modbus Gateway(Pro)

4.1 Interfaces

4.1.1 Interface Function Drawing

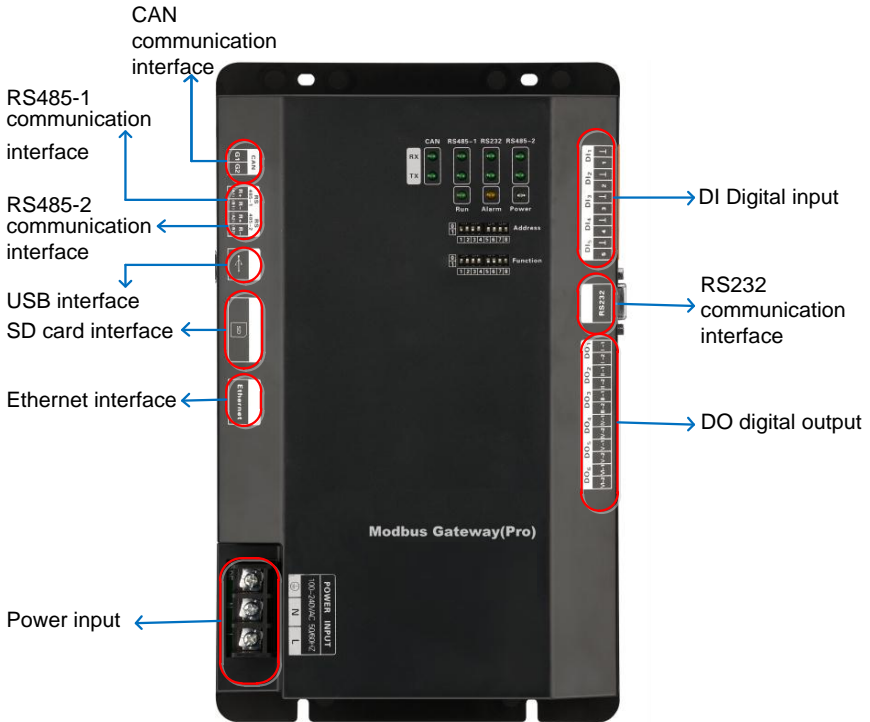

4.1.2 Power

The input power is 100VAC-240VAC and 50/60Hz.

⚠ WARNING!

Protective grounding of power input must be connected, otherwise a hazard may happen; in addition, do not touch the power input when the gateway is energized.



⚠ Notice! Power cord should be secured with the equipped wire clip, as shown in the figure.

4.1.3 Communication interfaces



CAN communication interface: It is connected to air conditioner through two-core connection wire, to realize communication between Modbus Gateway(Pro) and air conditioner.

RS485-1 communication interface: It is connected to BMS through two-core connection wire, to realize communication between Modbus Gateway(Pro) and BMS.

RS485-2 communication interface: This device doesn't use this communication interface currently.

Interface of USB or SD card: This device doesn't use this interface currently.

Ethernet interface: This device doesn't use this interface currently.

4.1.4 DI/DO Digital Input/Output

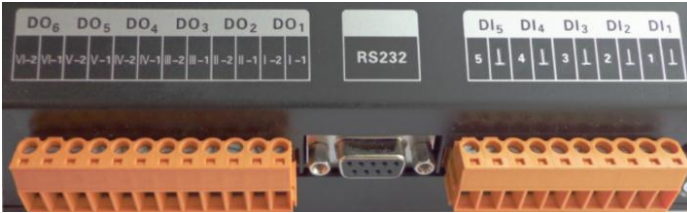

This gateway supports 5 DIs(digital inputs) and 5 DOs(digital outputs); DO6 is reserved.

DI1...DI5

Digital inputs: 0/1 digital signals(binary system), applicable for those with power supply

DI1: in CAN2 network, fire alarm signal, connect “1” to the power of 12V, input fire alarm signal “1” in DI 1 port, then Modbus gateway(Pro) will give out control, all units stop operation immediately;disconnect “1” or connect to “0” , input signal “0” in DI 1 port,resume operation of all ODU.

In CAN1 network, fire alarm signal, connect “1” to the power of 12V, input fire alarm signal “1” in DI 1 port, then Modbus gateway(Pro) will give out control, all units stop operation immediately;disconnect “1” or connect to “0”, input signal “0” in DI 1 port,resume operation of IDUs manually.

DI2...DI5: Defined by the user.

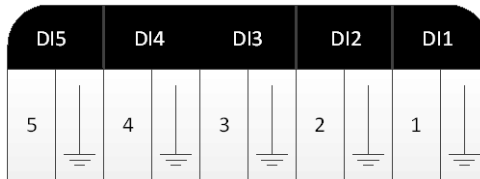

DO1...DO5 digital outputs: Relay output, normally-open contact

Max admissible power: 250VAC, 3A; 30VDC, 3A

Example: write “1” into DO5 of Modbus protocol and the two contacts of DO5 relay will be closed; write “0” into DO5 of Modbus protocol and the two contacts of DO5 relay will be cut off.

4.2 LED display



LED indicators shown in the above figure are divided into two parts: status indicators (operation, alarm, power) and communication indicators(CAN, RS485, RS232). Operation status of each indicator is shown in the following table.

CAN	RX	When the data from the equipment (e.g. air conditioner) connected with Modbus Gateway(Pro) is received, it will flash.
CAN	TX	When the data is transferred to the equipment (e.g. air conditioner) connected with Modbus Gateway(Pro), it will flash.
RS485-1	RX	When the data from the Modbus bus is received, it will flash.
RS485-1	TX	When the data is transferred to the Modbus bus, it will flash.
RS232	RX	This device does not use this LED indicator.
RS232	TX	This device does not use this LED indicator.
RS485-2	RX	This device does not use this LED indicator.
RS485-2	TX	This device does not use this LED indicator.
Power		When power supply of Modbus Gateway(Pro) is normal, it will be always on..
Run		When Modbus Gateway(Pro) works normally, it will blink.
Alarm		This device doesn't use this LED indicator.

4.3 DIP Switches



Notice! Please set DIP switches before using this device, otherwise this device cannot operate normally!

This gateway includes two kinds of DIP switches, address DIP switch and function DIP switch.



4.3.1 Diagram of DIP Switches

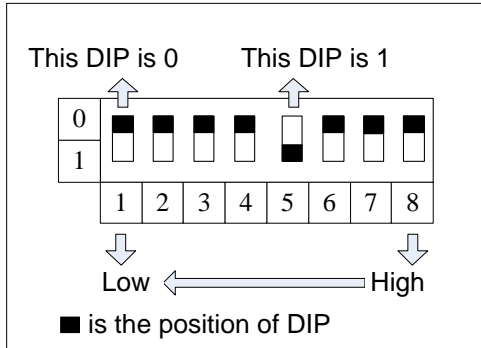

4.3.2 Address DIP Switch-Address Setting of Modbus Gateway(Pro)

Address DIP switch is used for setting the device address of Modbus Gateway(Pro).

! Notice! Please set the address DIP switches before using this gateway. The network DIP switch address of the same bus cannot be repeated, otherwise communication error may happen.

Address setting range: 1~255.

Address setting example:

Setting method of address 11 is shown as below:

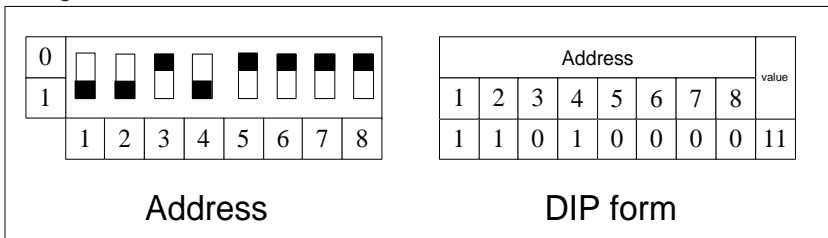

Setting method of address 43 is shown as below:

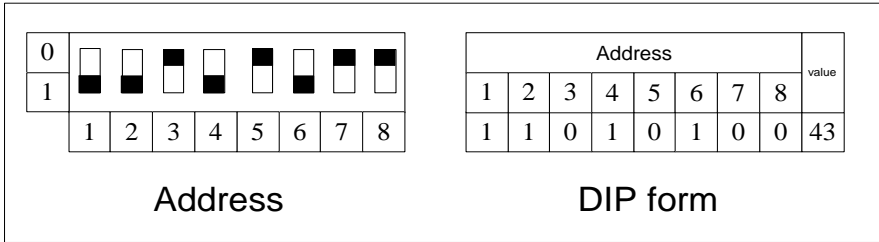

4.3.3 The Seventh Switch of Function DIP Switch-Setting of Modbus Bus Matched Resistance

! Notice! Master outdoor unit or gateway of the system which is at the end of Modbus bus must be set as with the matched resistance, otherwise communication will be abnormal!

Modbus bus: Detailed meaning please refer to topology introduction.

The seventh switch of function DIP switch is used for setting the Modbus bus matched resistance of this gateway.

If the gateway is at the end of Modbus bus, the gateway shall be set as with the matched resistance, which means set the seventh DIP switch to 0;

If the gateway is not at the end of Modbus bus, the gateway shall be set as without the matched resistance, which means set this DIP switch to 1.

DIP switch of matched resistance is shown as below:

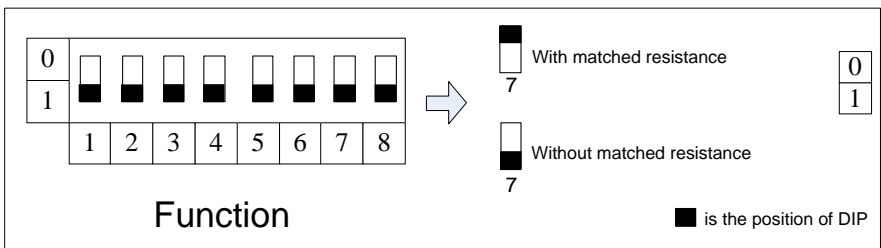

4.3.4 The Eighth Switch of Function DIP Switch – Setting of CAN2 Bus Matched Resistance

! Notice! Master outdoor unit or gateway of the system which is at the end of CAN2 bus must be set as with the matched resistance, otherwise communication will be abnormal!

※CAN2 bus: Detailed meaning please refer to topology introduction.

The eighth switch of function DIP switch is used for setting the CAN2 bus matched resistance of this gateway.

If the gateway is at the end of CAN2 bus, the gateway shall be set as with the matched resistance, which means set the eighth DIP switch to 0;

If the gateway is not at the end of CAN2 bus, the gateway shall be set as without the matched resistance, which means set the eighth DIP switch to 1.

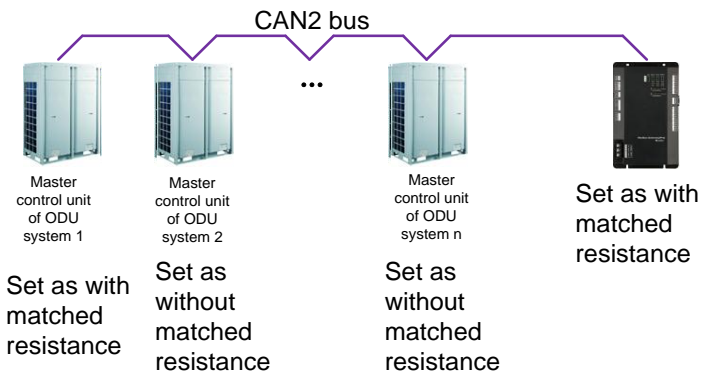
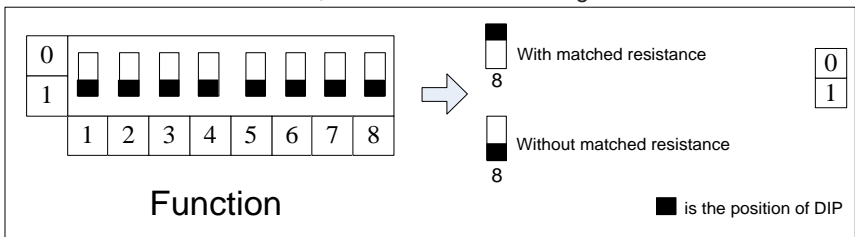

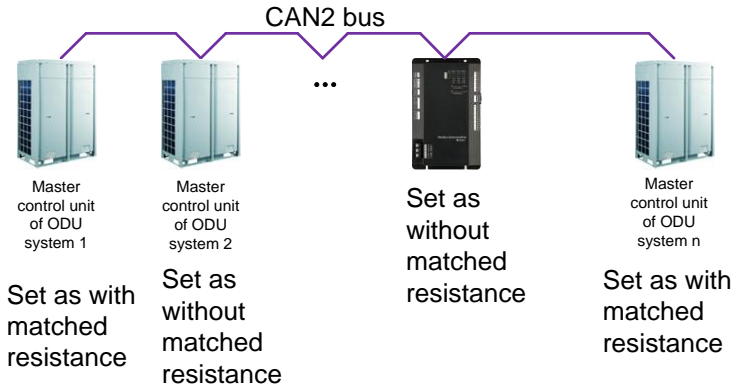

5 Application

Modbus Gateway(Pro) is usually applicable for Building Management System.

5.1 Building Management System (BMS)

This gateway adopts Modbus standard protocol, which can be used as the interface of BMS. It is applicable for Gree multi VRF which adopts CAN protocol when the VRF is connected to the BMS, to achieve monitoring of Gree multi VRF with BMS.

5.2 Internet topological graph

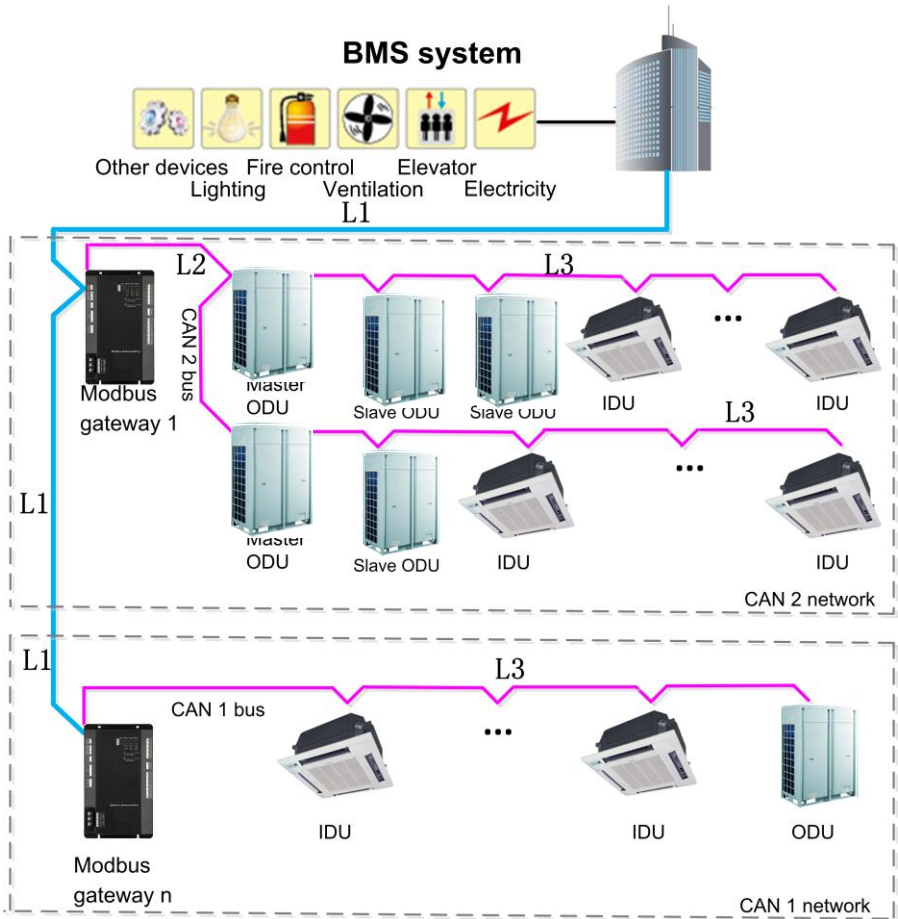

5.3 Topology Introduction:

Modbus bus: L1 shown in the figure is the Modbus bus.

CAN1 network: which is consist of Modbus Gateway(Pro) and all IDUs and ODUs of the system. One CAN1 network can be connected to maximum 80 IDUs.

CAN2 network: which is consist of Modbus Gateway(Pro) and main control ODU of the system. One CAN2 network can be connected to maximum 16 systems and 255 IDUs.

System: One system consists of one set of outdoor unit (one set of outdoor unit is a module group consisting of 1~4 modules, that is 1~4 outdoor units) and it'

s connected indoor units.

Connectable unit quantity of Modbus Gateway(Pro): one Modbus Gateway(Pro) can be connected with 16 systems and 255 indoor units in maximum.

6 Installation

6.1 Product Dimension and Installation Space of Electric Control Cabinet

6.1.1 Product Dimension

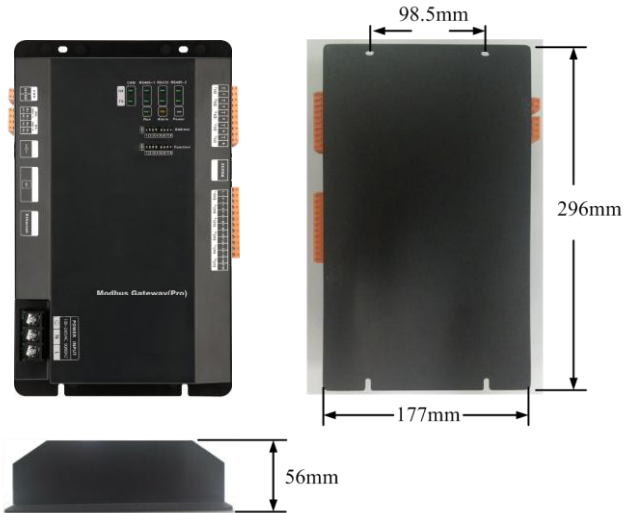

L x W x H: 296x177x56 (mm)

6.1.2 Installation Space of Electric Control Cabinet

Modbus Gateway(Pro) shall be installed in the electric control cabinet. The front side of gateway shall be hung upwards and secured by four screws. Required installation space is shown as below (only for reference).

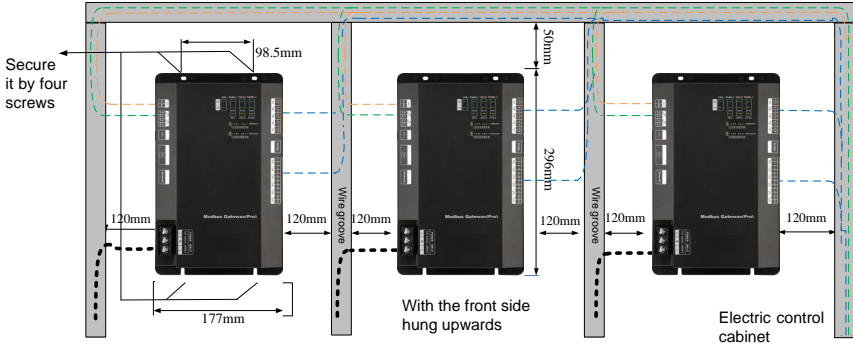

6.2 Communication Connection

Communication system of Modbus Gateway(Pro) includes:

- (1) Communication between Modbus Gateway(Pro) and BMS;
- (2) Communication between Modbus Gateway(Pro) and air conditioner.

6.2.1 Material Selection of Communication Cable

Communication system	Material of cable	Communication cable L(m)	Cable diameter (mm ²)	Material standard	Remark
Modbus Gateway(Pro) and BMS	Light/Ordinary PVC sheathed twisted pair copper wire(60227 IEC52/60227 IEC53)	L ≤ 800	≥ 2×0.75	IEC60227-5 :2007	When communication distance exceeds 800m, photoelectric isolation repeater shall be added
Modbus Gateway(Pro) and air conditioner	Light/Ordinary PVC sheathed twisted pair copper wire(60227 IEC52/60227 IEC53)	L ≤ 500	≥ 2×0.75	IEC60227-5 :2007	The length of communication cable shall not exceed 500m

6.2.2 Communication Connection Way

! Notice! All communication cables of Modbus Gateway(Pro) must be connected in series instead of in star mode.

(1) Communicaiton connection between Modbus and BMS;

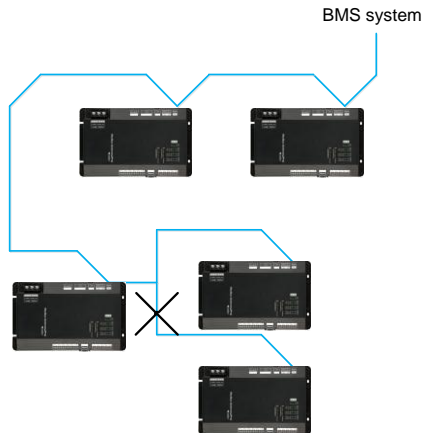
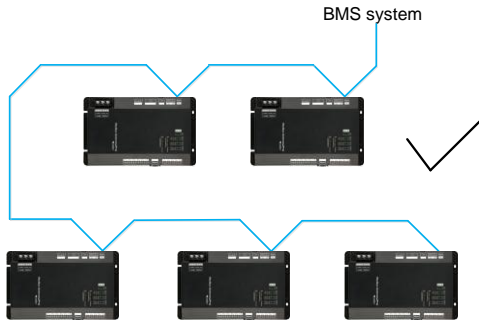

Modbus Gateway(Pro)

(2) Communicaiton connection between Modbus Gateway(Pro) and air conditioner (n is air conditioner quantity, $n \leq 255$);

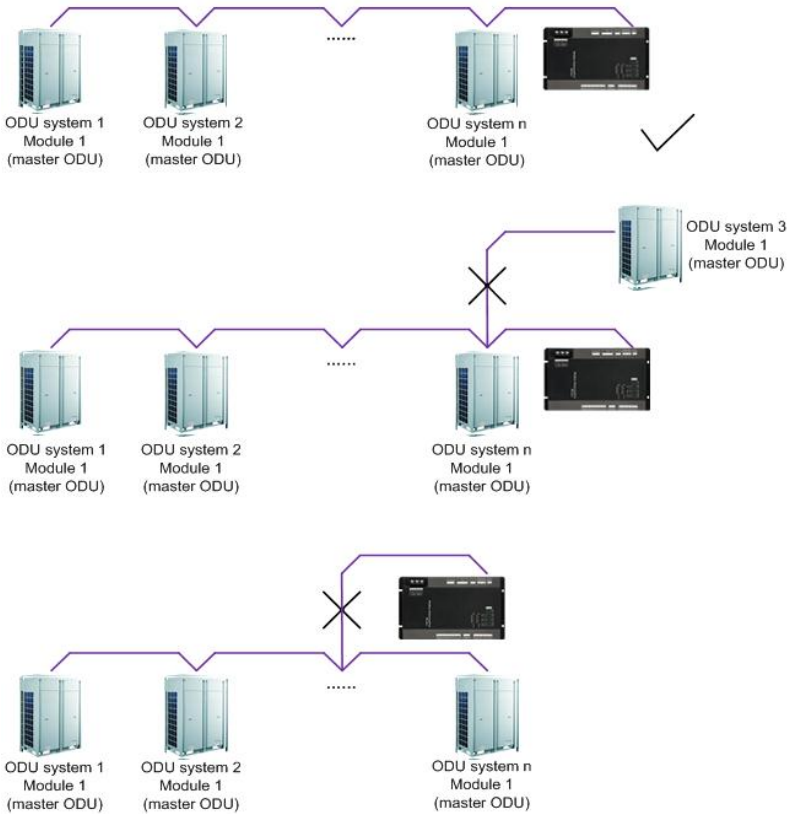

6.2.3 Setting of Communication Connection

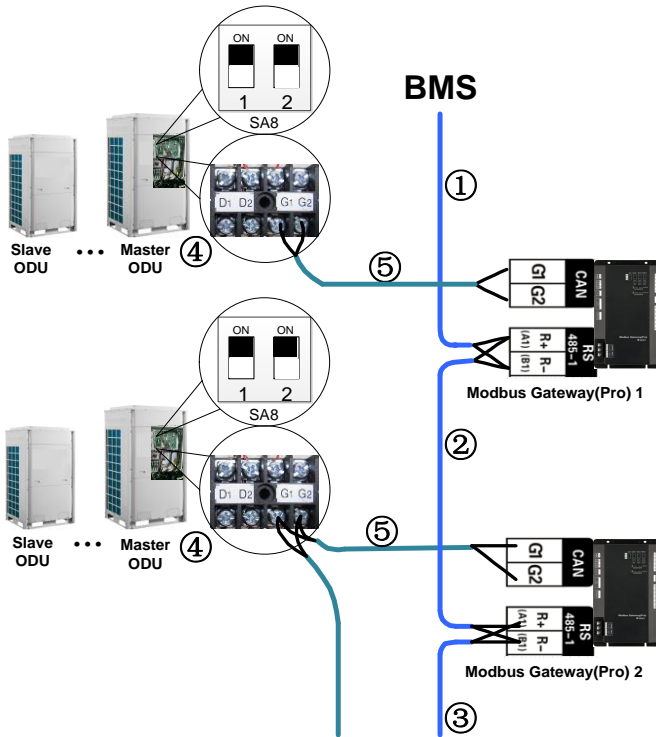

(1) Communication wire connection between Modbus Gateway(Pro) and BMS:

Step 1: Confirm the first Modbus Gateway(Pro) (Modbus Gateway(Pro)1 as shown in the figure) that needs to be connected to BMS. Connect the R+ and R- port of RS485-1 communication interface of this gateway and the BMS with communication cable, as shown in step ① in the figure.

Step 2: Connect the R+ and R- port of RS485-1 communication interface of Modbus Gateway(Pro)(Modbus Gateway(Pro)1) and the R+ and R- port of RS485-1 communication interface of the second Modbus Gateway(Pro)(Modbus Gateway(Pro)2 as shown in the figure) with communication cable, as shown in step ② in the figure. If several Modbus Gateways(Pro) shall be connected, please connect them in this way.

Modbus Gateway(Pro)

(2) Communication wire connection between Modbus Gateway(Pro) and air conditioner:

Step 1: Confirm the master ODU that each Modbus Gateway(Pro) shall be connected. Please refer to “6.2.2(2) Communicaiton connection between Modbus Gateway(Pro) and air conditioner” and adopt series connection, as shown in step ④ in the figure.

Step 2: Connect the G1 and G2 port of CAN communication interface of Modbus Gateway(Pro) and the G1 and G2 port of wiring board of corresponding master ODU with communication cable, as shown in step ⑤ in the figure.

(3) DIP switch of Modbus Gateway(Pro):

Step 1: Set address DIP switch of Modbus Gateway(Pro) by referring to chapter 4.3.2.

Step 2: Set matched resistance of Modbus Gateway(Pro) by referring to chapter 4.3.3 - 4.3.4.

Note:

① In Modbus bus, if the connected Modbus Gateway(Pro) exceeds 30 or communication distance exceeds 800m, one photoelectric isolation repeater shall be added. Connect the R+ and R- port of photoelectric isolation repeater with the R+ and R- port of RS485-1 communication interface of nearby Modbus Gateway(Pro).

30 Modbus gateways in maximum between two repeaters



Total accumulative length of communication cable between two repeaters shall not exceed 800m

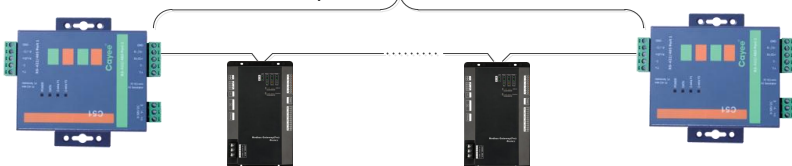

② In “The eighth switch of function DIP switch – setting of CAN2 bus matched resistance”, the setting method of matched resistance of Modbus Gateway(Pro) is introduced. Meanwhile, the master ODU in the first and end systems of CAN2 bus shall be set as with matched resistance. In the following, the detailed setting position and method of matched resistance of GMV 5 DC inverter multi VRF are taken as example.

Master ODU

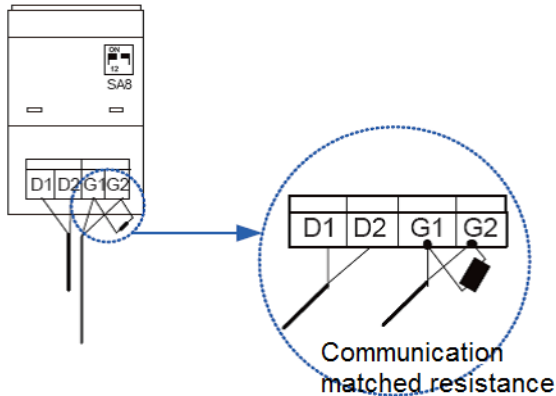

※CAN2 bus: Detailed meaning please refer to topology introduction.

7 Annex: DIP Address

0~31 DIP address table									32~63 DIP address table								
1	2	3	4	5	6	7	8	addr	1	2	3	4	5	6	7	8	addr
0	0	0	0	0	0	0	0	\	0	0	0	0	0	1	0	0	32
1	0	0	0	0	0	0	0	1	1	0	0	0	0	1	0	0	33
0	1	0	0	0	0	0	0	2	0	1	0	0	0	1	0	0	34
1	1	0	0	0	0	0	0	3	1	1	0	0	0	1	0	0	35
0	0	1	0	0	0	0	0	4	0	0	1	0	0	1	0	0	36
1	0	1	0	0	0	0	0	5	1	0	1	0	0	1	0	0	37
0	1	1	0	0	0	0	0	6	0	1	1	0	0	1	0	0	38
1	1	1	0	0	0	0	0	7	1	1	1	0	0	1	0	0	39
0	0	0	1	0	0	0	0	8	0	0	0	1	0	1	0	0	40
1	0	0	1	0	0	0	0	9	1	0	0	1	0	1	0	0	41
0	1	0	1	0	0	0	0	10	0	1	0	1	0	1	0	0	42
1	1	0	1	0	0	0	0	11	1	1	0	1	0	1	0	0	43
0	0	1	1	0	0	0	0	12	0	0	1	1	0	1	0	0	44
1	0	1	1	0	0	0	0	13	1	0	1	1	0	1	0	0	45
0	1	1	1	0	0	0	0	14	0	1	1	1	0	1	0	0	46
1	1	1	1	0	0	0	0	15	1	1	1	1	0	1	0	0	47
0	0	0	0	1	0	0	0	16	0	0	0	0	1	1	0	0	48
1	0	0	0	1	0	0	0	17	1	0	0	0	1	1	0	0	49
0	1	0	0	1	0	0	0	18	0	1	0	0	1	1	0	0	50
1	1	0	0	1	0	0	0	19	1	1	0	0	1	1	0	0	51
0	0	1	0	1	0	0	0	20	0	0	1	0	1	1	0	0	52
1	0	1	0	1	0	0	0	21	1	0	1	0	1	1	0	0	53
0	1	1	0	1	0	0	0	22	0	1	1	0	1	1	0	0	54
1	1	1	0	1	0	0	0	23	1	1	1	0	1	1	0	0	55
0	0	0	1	1	0	0	0	24	0	0	0	1	1	1	0	0	56
1	0	0	1	1	0	0	0	25	1	0	0	1	1	1	0	0	57
0	1	0	1	1	0	0	0	26	0	1	0	1	1	1	0	0	58
1	1	0	1	1	0	0	0	27	1	1	0	1	1	1	0	0	59
0	0	1	1	1	0	0	0	28	0	0	1	1	1	1	0	0	60
1	0	1	1	1	0	0	0	29	1	0	1	1	1	1	0	0	61
0	1	1	1	1	0	0	0	30	0	1	1	1	1	1	0	0	62
1	1	1	1	1	0	0	0	31	1	1	1	1	1	1	0	0	63

64~95 DIP address table									96~127 DIP address table								
1	2	3	4	5	6	7	8	addr	1	2	3	4	5	6	7	8	addr
0	0	0	0	0	0	1	0	64	0	0	0	0	0	1	1	0	96
1	0	0	0	0	0	1	0	65	1	0	0	0	0	1	1	0	97
0	1	0	0	0	0	1	0	66	0	1	0	0	0	1	1	0	98
1	1	0	0	0	0	1	0	67	1	1	0	0	0	1	1	0	99
0	0	1	0	0	0	1	0	68	0	0	1	0	0	1	1	0	100
1	0	1	0	0	0	1	0	69	1	0	1	0	0	1	1	0	101
0	1	1	0	0	0	1	0	70	0	1	1	0	0	1	1	0	102
1	1	1	0	0	0	1	0	71	1	1	1	0	0	1	1	0	103
0	0	0	1	0	0	1	0	72	0	0	0	1	0	1	1	0	104
1	0	0	1	0	0	1	0	73	1	0	0	1	0	1	1	0	105
0	1	0	1	0	0	1	0	74	0	1	0	1	0	1	1	0	106
1	1	0	1	0	0	1	0	75	1	1	0	1	0	1	1	0	107
0	0	1	1	0	0	1	0	76	0	0	1	1	0	1	1	0	108
1	0	1	1	0	0	1	0	77	1	0	1	1	0	1	1	0	109
0	1	1	1	0	0	1	0	78	0	1	1	1	0	1	1	0	110
1	1	1	1	0	0	1	0	79	1	1	1	1	0	1	1	0	111
0	0	0	0	1	0	1	0	80	0	0	0	0	1	1	1	0	112
1	0	0	0	1	0	1	0	81	1	0	0	0	1	1	1	0	113
0	1	0	0	1	0	1	0	82	0	1	0	0	1	1	1	0	114
1	1	0	0	1	0	1	0	83	1	1	0	0	1	1	1	0	115
0	0	1	0	1	0	1	0	84	0	0	1	0	1	1	1	0	116
1	0	1	0	1	0	1	0	85	1	0	1	0	1	1	1	0	117
0	1	1	0	1	0	1	0	86	0	1	1	0	1	1	1	0	118
1	1	1	0	1	0	1	0	87	1	1	1	0	1	1	1	0	119
0	0	0	1	1	0	1	0	88	0	0	0	1	1	1	1	0	120
1	0	0	1	1	0	1	0	89	1	0	0	1	1	1	1	0	121
0	1	0	1	1	0	1	0	90	0	1	0	1	1	1	1	0	122
1	1	0	1	1	0	1	0	91	1	1	0	1	1	1	1	0	123
0	0	1	1	1	0	1	0	92	0	0	1	1	1	1	1	0	124
1	0	1	1	1	0	1	0	93	1	0	1	1	1	1	1	0	125
0	1	1	1	1	0	1	0	94	0	1	1	1	1	1	1	0	126
1	1	1	1	1	0	1	0	95	1	1	1	1	1	1	1	0	127

Modbus Gateway(Pro)

128~159 DIP address table									160~191 DIP address table								
1	2	3	4	5	6	7	8	addr	1	2	3	4	5	6	7	8	addr
0	0	0	0	0	0	0	1	128	0	0	0	0	0	1	0	1	160
1	0	0	0	0	0	0	1	129	1	0	0	0	0	1	0	1	161
0	1	0	0	0	0	0	1	130	0	1	0	0	0	1	0	1	162
1	1	0	0	0	0	0	1	131	1	1	0	0	0	1	0	1	163
0	0	1	0	0	0	0	1	132	0	0	1	0	0	1	0	1	164
1	0	1	0	0	0	0	1	133	1	0	1	0	0	1	0	1	165
0	1	1	0	0	0	0	1	134	0	1	1	0	0	1	0	1	166
1	1	1	0	0	0	0	1	135	1	1	1	0	0	1	0	1	167
0	0	0	1	0	0	0	1	136	0	0	0	1	0	1	0	1	168
1	0	0	1	0	0	0	1	137	1	0	0	1	0	1	0	1	169
0	1	0	1	0	0	0	1	138	0	1	0	1	0	1	0	1	170
1	1	0	1	0	0	0	1	139	1	1	0	1	0	1	0	1	171
0	0	1	1	0	0	0	1	140	0	0	1	1	0	1	0	1	172
1	0	1	1	0	0	0	1	141	1	0	1	1	0	1	0	1	173
0	1	1	1	0	0	0	1	142	0	1	1	1	0	1	0	1	174
1	1	1	1	0	0	0	1	143	1	1	1	1	0	1	0	1	175
0	0	0	0	1	0	0	1	144	0	0	0	0	1	1	0	1	176
1	0	0	0	1	0	0	1	145	1	0	0	0	1	1	0	1	177
0	1	0	0	1	0	0	1	146	0	1	0	0	1	1	0	1	178
1	1	0	0	1	0	0	1	147	1	1	0	0	1	1	0	1	179
0	0	1	0	1	0	0	1	148	0	0	1	0	1	1	0	1	180
1	0	1	0	1	0	0	1	149	1	0	1	0	1	1	0	1	181
0	1	1	0	1	0	0	1	150	0	1	1	0	1	1	0	1	182
1	1	1	0	1	0	0	1	151	1	1	1	0	1	1	0	1	183
0	0	0	1	1	0	0	1	152	0	0	0	1	1	1	0	1	184
1	0	0	1	1	0	0	1	153	1	0	0	1	1	1	0	1	185
0	1	0	1	1	0	0	1	154	0	1	0	1	1	1	0	1	186
1	1	0	1	1	0	0	1	155	1	1	0	1	1	1	0	1	187
0	0	1	1	1	0	0	1	156	0	0	1	1	1	1	0	1	188
1	0	1	1	1	0	0	1	157	1	0	1	1	1	1	0	1	189
0	1	1	1	1	0	0	1	158	0	1	1	1	1	1	0	1	190
1	1	1	1	1	0	0	1	159	1	1	1	1	1	1	0	1	191

192~223 DIP address table									224~255 DIP address table								
1	2	3	4	5	6	7	8	addr	1	2	3	4	5	6	7	8	addr
0	0	0	0	0	0	1	1	192	0	0	0	0	0	1	1	1	224
1	0	0	0	0	0	1	1	193	1	0	0	0	0	1	1	1	225
0	1	0	0	0	0	1	1	194	0	1	0	0	0	1	1	1	226
1	1	0	0	0	0	1	1	195	1	1	0	0	0	1	1	1	227
0	0	1	0	0	0	1	1	196	0	0	1	0	0	1	1	1	228
1	0	1	0	0	0	1	1	197	1	0	1	0	0	1	1	1	229
0	1	1	0	0	0	1	1	198	0	1	1	0	0	1	1	1	230
1	1	1	0	0	0	1	1	199	1	1	1	0	0	1	1	1	231
0	0	0	1	0	0	1	1	200	0	0	0	1	0	1	1	1	232
1	0	0	1	0	0	1	1	201	1	0	0	1	0	1	1	1	233
0	1	0	1	0	0	1	1	202	0	1	0	1	0	1	1	1	234
1	1	0	1	0	0	1	1	203	1	1	0	1	0	1	1	1	235
0	0	1	1	0	0	1	1	204	0	0	1	1	0	1	1	1	236
1	0	1	1	0	0	1	1	205	1	0	1	1	0	1	1	1	237
0	1	1	1	0	0	1	1	206	0	1	1	1	0	1	1	1	238
1	1	1	1	0	0	1	1	207	1	1	1	1	0	1	1	1	239
0	0	0	0	1	0	1	1	208	0	0	0	0	1	1	1	1	240
1	0	0	0	1	0	1	1	209	1	0	0	0	1	1	1	1	241
0	1	0	0	1	0	1	1	210	0	1	0	0	1	1	1	1	242
1	1	0	0	1	0	1	1	211	1	1	0	0	1	1	1	1	243
0	0	1	0	1	0	1	1	212	0	0	1	0	1	1	1	1	244
1	0	1	0	1	0	1	1	213	1	0	1	0	1	1	1	1	245
0	1	1	0	1	0	1	1	214	0	1	1	0	1	1	1	1	246
1	1	1	0	1	0	1	1	215	1	1	1	0	1	1	1	1	247
0	0	0	1	1	0	1	1	216	0	0	0	1	1	1	1	1	248
1	0	0	1	1	0	1	1	217	1	0	0	1	1	1	1	1	249
0	1	0	1	1	0	1	1	218	0	1	0	1	1	1	1	1	250
1	1	0	1	1	0	1	1	219	1	1	0	1	1	1	1	1	251
0	0	1	1	1	0	1	1	220	0	0	1	1	1	1	1	1	252
1	0	1	1	1	0	1	1	221	1	0	1	1	1	1	1	1	253
0	1	1	1	1	0	1	1	222	0	1	1	1	1	1	1	1	254
1	1	1	1	1	0	1	1	223	1	1	1	1	1	1	1	1	255



600005060050