



Owner's Manual

Original Instructions

BACnet Gateway



Models:ME30-24/D4(B)



User Notice

Dear customer:

Please read this manual carefully prior to installation and operation and strictly observe all installation and operation instructions covered in the manual.

Special attentions shall be paid to the following marks:

 WARNING!	This mark indicates operation, which if improperly performed, might lead to the death or serious injury of the users.
 CAUTION!	This mark indicates operation, which if improperly performed, might possibly result in damage to the device.

 WARNING!	
(1)	Installation shall be performed by the qualified personnel; otherwise it would result in a fire hazard or electric shock.
(2)	Do not place the plug of the power supply into the socket before it is dried and cleaned.
(3)	Cut off the power supply before touching the electric element.
(4)	Do not touch this device with wet hands; otherwise it would result in electric shock.
(5)	Do use the power cable specified in this manual; otherwise it would result in a fire hazard.
(6)	When the power cable is reversely connected or the power supply is beyond the rated range, it would result in a fire hazard or even damages to this device.
(7)	For PLUGGABLE EQUIPMENT, the socket-outlet shall be installed near the equipment and shall be easily accessible.
(8)	Do install this device inside the electric control cabinet which is located indoor and then is locked.
(9)	Do install this device where it will not be subject to the electromagnetic interference or heavy dust.
 CAUTION!	
(1)	Be sure the specified adaptor is used; otherwise this device would work improperly or even be damaged.
(2)	Be sure this device is setup in place; otherwise it would result in communication fault.
(3)	Be sure the communication line is connected to the correct interface; otherwise

it would result in communication fault.

(4) After connection, lines should be protected with insulating tape to avoid oxidation and short circuits.

(5) Risk of explosion if battery is replaced by an incorrect type, dispose of used batteries according to the instructions.

(6) Normal working conditions for BACnet gateway:

① Temperature : 0~55℃;

② Humidity: less than 95%

③ Location: indoor (it is highly recommended to install this product in the electric control cabinet), not subject to direct sunlight, rain and snow etc.

(7) Graphics in the instruction manual are for reference only.

Contents

1 FUNCTION AND PARAMETER.....	1
1.1 FUNCTIONAL OVERVIEW.....	1
1.2 PARAMETER SPECIFICATIONS	1
2 PARTS AND ASSEMBLY	2
3 INTRODUCTION FOR BACNET GATEWAY	2
3.1 INTERFACE	2
3.2 LED DISPLAY.....	5
3.3 DIAL-UP.....	5
4 APPLICATION.....	8
4.1 (BMS)BUILDING MANAGEMENT SYSTEM (BMS).....	8
4.2 INTERNET TOPOLOGICAL GRAPH.....	8
5 PRODUCT INSTALLATION.....	10
5.1 PRODUCT SIZE AND SPATIAL SIZE FOR ELECTRIC CONTROL CABINET INSTALLATION.....	10
5.2 COMMUNICATION CONNECTION	11
6 BACNET PROTOCOL	16
6.1 STRUCTURE OF BACNET PROTOCOL.....	16
6.2 OBJECT AND PROPERTY OF BACNET PROTOCOL	16
ATTACHMENT A PARAMETER OF AIR CONDITIONER (PROTOCOL VERSION V1.0.0)	18
ATTACHMENT B TCP/IP SETTING.....	25

1 Function and parameter

1.1 Functional overview

GMV BACnet gateway kit ME30-24/D4(B) is intended to realize the data exchange between the air conditioning unit and BAS system, and providing standard BACnet/IP building interface and 10 I/Os (five inputs are DI1, DI2, DI3, DI4, DI5 and five outputs are DO1, DO2, DO3, DO4, DO5). DI1 is the fire alarm interface. The status of other I/Os are mapped to the specific objects of the BACnet/IP bus and are defined by the user. This gateway applies to the GMV using CAN protocol.



1.2 Parameter specifications

1.2.1 BACnet gateway TCP/IP parameter (default)

IP Address: 192.168.1.150;

Subnet Mask: 255.255.255.0;

Default gateway: 192.168.1.1。

CAUTION!

Please reenergize the gateway to make the modified TCP/IP data effective.

1.2.2 BACnet gateway building interface parameter

Parameters of all kinds of supportive air conditioners shall refer to Attachment A: Parameter of Air Conditioner.

2 Parts and assembly

This kit includes the following parts. Please check before installation.

BACnet gateway	1 set
Instruction manual	1 set

3 Introduction for BACnet gateway

3.1 Interface

3.1.1 Diagram of interface function

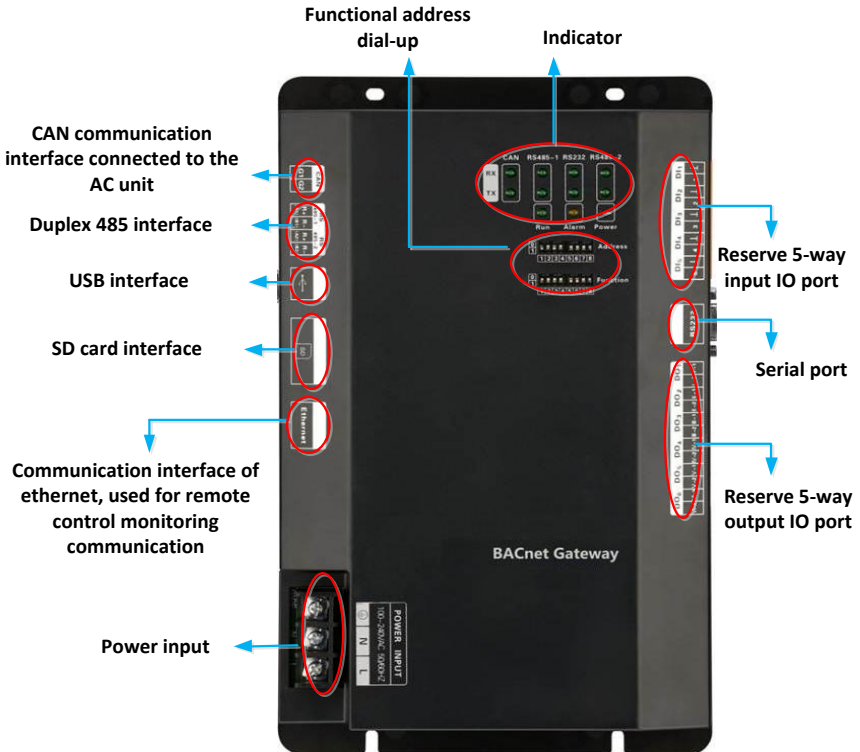

3.1.2 Power

The input power is 100VAC-240VAC and 50/60Hz

⚠ WARNING! The ground protection of power input port must be connected, otherwise it might be dangerous; besides, when the gateway is energized, don't touch the power input.



Note! the power cord shall be fixed with bonding clamp in the kit, as shown in the fig.

3.1.3 Communication interface



CAN communication interface: connect it to the AC unit through the 2-core communication line to realize the communication between BACnet gateway and the AC which adopts CAN protocol.

RS485-1 communication interface: this device will not use this communication interface temporarily.

RS485-2 communication interface: this device will not use this communication interface temporarily.

USB and SD card interface: this device will not use this interface temporarily.

Ethernet interface: realize communication through network cable and BMS.

3.1.4 Input/output of DI/DO digital quantity



So far, this gateway supports 5 DIs (digital input) and 5 Dos (digital output), DO6 is reserved.

DI1...DI5

Digital input 0/1 digital signal (binary system), apply to active input.

DI 1: in CAN2 network, fire alarm signal, connect “1” to the power of 12V, input fire alarm signal “1” in DI 1 port, then BACnet gateway will give out control, all units stop operation immediately; disconnect “1” or connect to “0”, input signal “0” in DI 1 port, resume operation of all ODUs.

In CAN1 network, fire alarm signal, connect “1” to the power of 12V, input fire alarm signal “1” in DI 1 port, then BACnet gateway will give out control, all units stop operation immediately; disconnect “1” or connect to “0”, input signal “0” in DI 1 port, resume operation of IDUs manually.

DI 2...DI 5:Defined by the user.

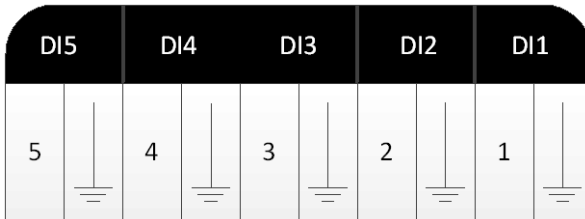

DO1...DO5

Digital output Relay output, turn on the contactor oftentimes

Maximum admissible electric quantity: 250VAC, 3A; 30VDC, 3A

Usage example: Input “1” in DO 5 of BACnet protocol, the two contactors of DO5 relay will close; input “0” in DO 5 of BACnet, the two contactors of DO 5 will cut off.

3.2 LED display

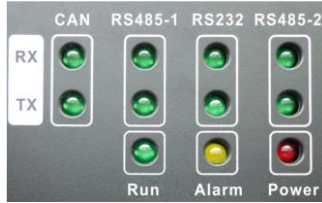

The above LED indicator is mainly consist of two parts: status indicator (run, alarm, power) and communication indicator (CAN, RS485, RS2332). The following table is the working status of each indicator.

CAN	RX	When receiving the data of equipment (eg. AC unit) which connects to BACnet gateway, it blinks.
CAN	TX	When transmitting data to the equipment (eg. AC unit) which connects to BACnet gateway, it blinks.
RS485-1	RX	This device does not use this LED indicator.
RS485-1	TX	This device does not use this LED indicator.
RS232	RX	This device does not use this LED indicator.
RS232	TX	This device does not use this LED indicator.
RS485-2	RX	This device does not use this LED indicator.
RS485-2	TX	This device does not use this LED indicator.
Power		When power supply of BACnet gateway is normal, it is on.
Run		When BACnet gateway is running normally, it blinks.
Alarm		This device does not use this LED indicator.

3.3 Dial-up

! Notice!

Before using this device, please conduct dial-up setting first, otherwise the unit will not function normally!

Gateway dial-up setting area is consisting of address dial-up machine and function dial-up machine.



3.3.1 Diagram of dial-up machine

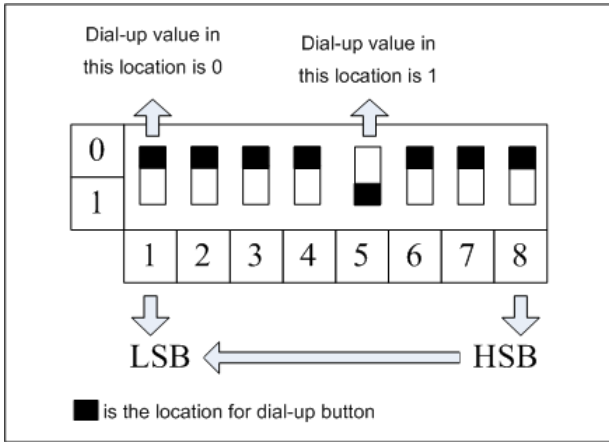

3.3.2 8 address dial-up buttons--gateway reset configuration

If information such as BACnet gateway IP address configured on the webpage, subnet mask, default gateway, gateway name and gateway ID are mistaken, and the webpage cannot be visited, dial up the 8 address dial-up buttons to “1”, after all indicating lights (except power indicating light) are blinking, reset the dial-up button and restart the gateway, then the default information in gateway manufacture setting can be restored.

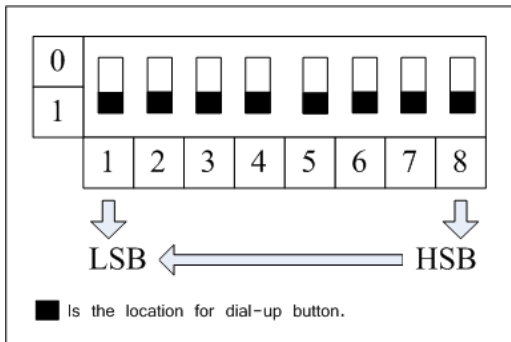

3.3.3 No.8 of functional dial-up machine--matched resistance setting of CAN bus

! Notice! Main control ODU or gateway at the top/end of CAN bus must be with matched resistance; otherwise the communication might be wrong!

※ CAN bus: specific meaning shall refer to the specification in Fig 4.2

Internet topological graph.

The No.8 dial-up button in function dial-up machine shall be used in the setting in the matched resistance of CAN bus in this gateway.

When the gateway is at the top/end of CAN bus, the gateway shall be with the matched resistance, then dial the No.8 function dial-up machine to 0;

When the gateway is not at the top/end of CAN bus, the gateway is not with the matched resistance, then dial it to 1.

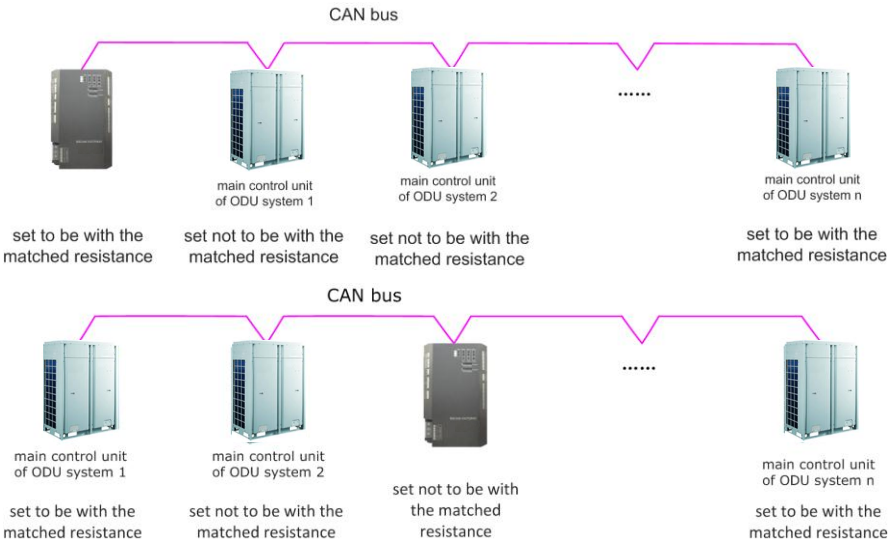

“n” stands for the quantity of ODU system, $n \leq 16$.

Dial-up setting graph for the matched resistance:

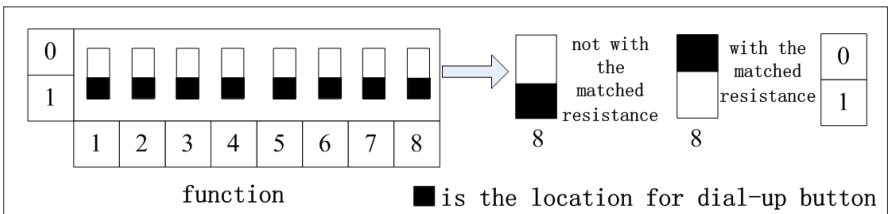

4 Application

Generally, the application occasion for BACnet gateway is building management system.

4.1 (BMS)Building Management System (BMS)

This gateway adopts BACnet standard protocol. It can connect to BAS system and Building Management System (BMS, Building Management System). It realizes the monitor of building management system to GMV through BACnet gateway.

4.2 Internet topological graph

Internet topological graph statement :

CAN2 bus internet: the red wire is CAN2 bus, which is consist of BACnet gateway and main control ODU of the system. One CAN2 internet can be connected to maximum 16 systems and 255 IDUs.

CAN1 bus internet: the black wire is CAN1 bus, which is consist of BACnet gateway and all IDUs and ODUs of the system. One CAN1 internet can be connected to maximum 80 IDUs.

System: one system is consisting of a set of ODU (a set of ODU is a module which is consist of 1-4 modules, namely 1-4 ODUs) and the affiliated IDUs.

The admissible unit quantity for BACnet gateway: one BACnet gateway can be connected to maximum 16 systems and 255 IDUs.

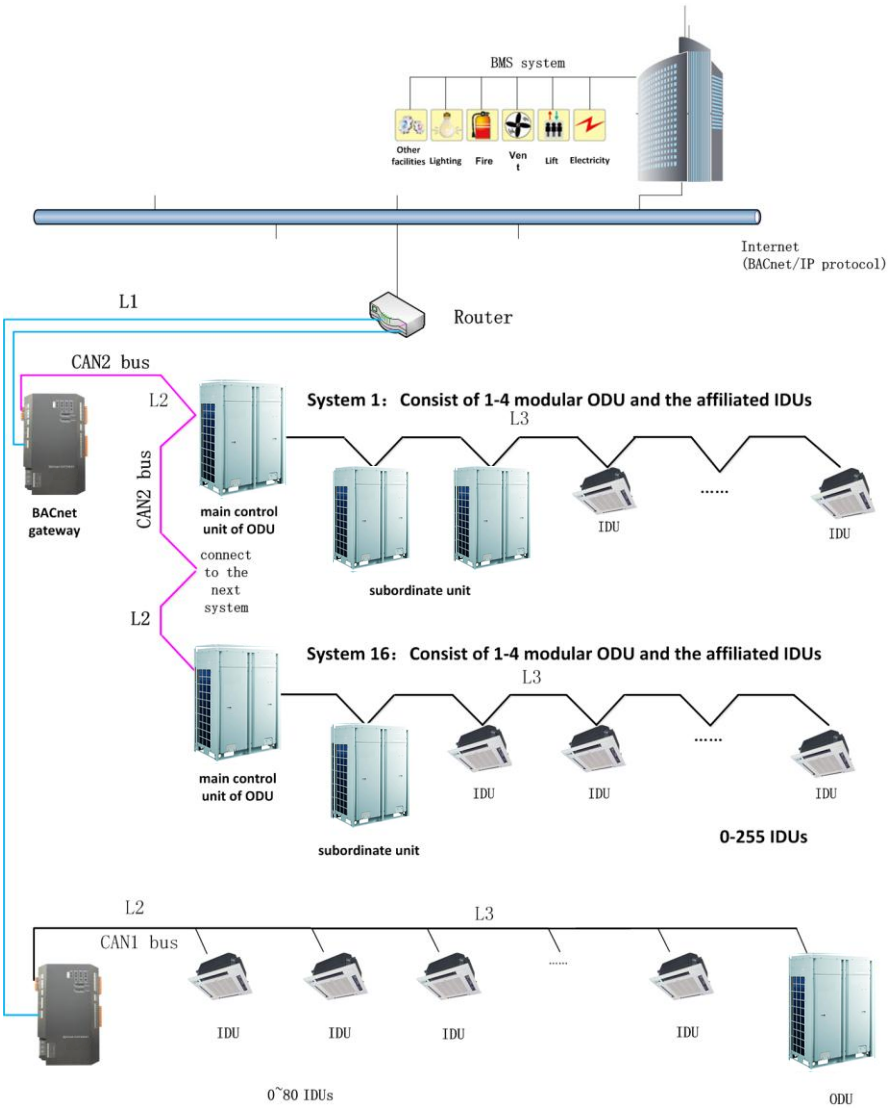

5 Product installation

5.1 Product size and spatial size for electric control cabinet installation

5.1.1 Product size

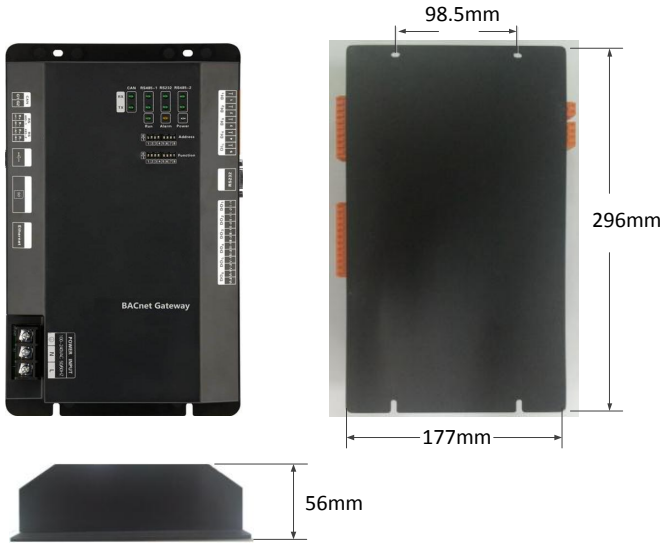

L x W x H: 296x177x56 (mm)

5.1.2 Spatial size for electric control cabinet installation

BACnet gateway shall be installed in electric control cabinet; the front of gateway shall be hung upward and fixed with 4 screws. See the following fig (for reference).

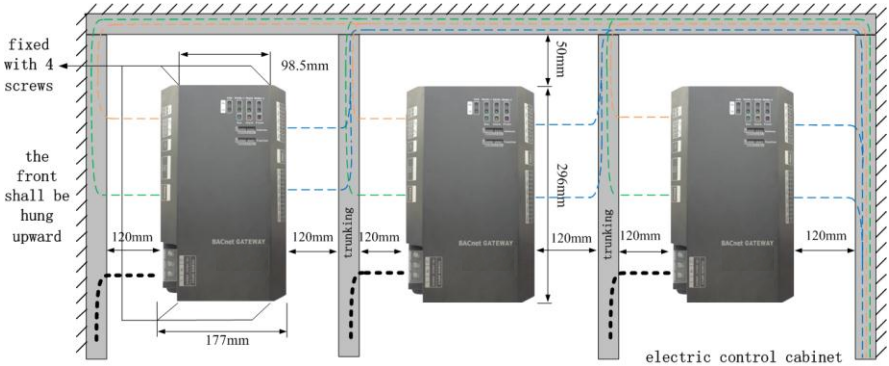

Warning! Power cord and communication line of BACnet gateway must conduct routing separately(the distance shall be over 15cm); otherwise, it might lead to BACnet gateway communication malfunction!

The thin dotted line is communication line and the thick dotted line is the heavy current wire, the routing shown is for reference only.

5.2 Communication connection

BACnet gateway communication system includes:

- (1) The communication between BACnet gateway and BMS;
- (2) The communication between BACnet gateway and AC units.

5.2.1 Material selection for communication line

(1) Model selection of BACnet gateway and BMS communication line shall use standard Ethernet communication line, the length of network cable between gateway and router (computer, switchboard, etc.) shall not exceed 80m;

(2) Communication line model selection for BACnet gateway and AC unit

Wire type	L(m)Communication line between gateway and AC units	Wire diameter(m ²)	Wire standard	Remark
Light-weight/normal PVC jacket twisted copper wire(RVV)	$L \leq 500$	$\geq 2 \times 0.75$	GB/T 5023.5-2008	Total communication length shall not exceed 500m

5.2.2 Communication connection method

(1) Communication connection between BACnet gateway and BMS;

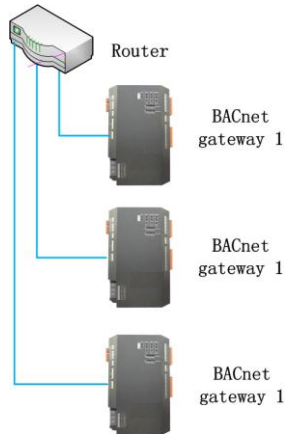

(2) Communication connection between BACnet gateway and AC units (n is the quantity of ODU system, $n \leq 16$);

! Notice! All communication connection lines under BACnet gateway must be in series connection, star connection shall not be adopted.



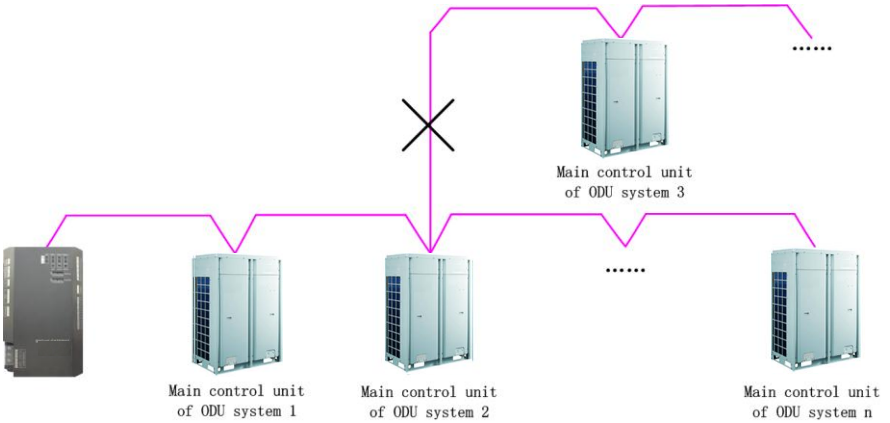
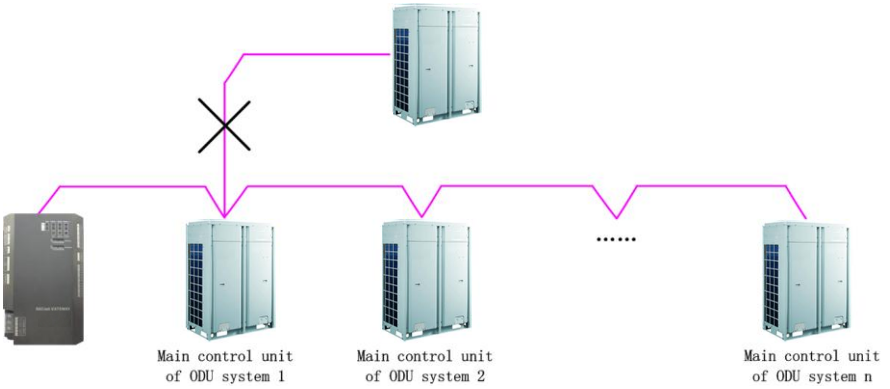

5.2.3 Communication connection configuration

(1) Communication line connection between BACnet gateway and PC:

Connection diagram between BACnet gateway and PC user side:

- 1) Adopt cross connection network cable, BACnet gateway shall directly connect to PC.

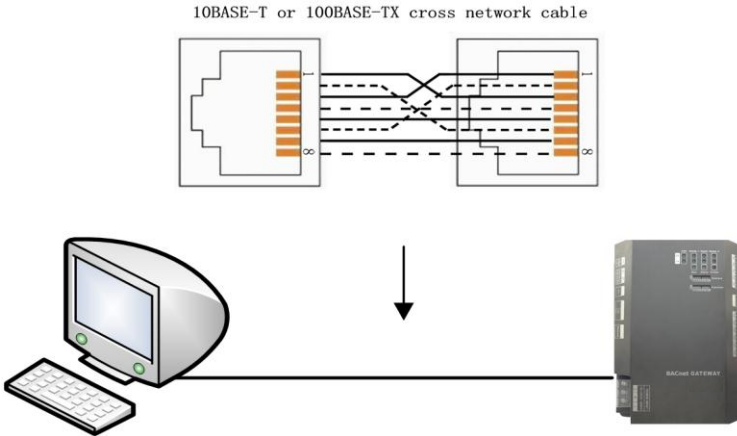

- 2) Adopt parallel network cable, BACnet gateway shall go through router to connect to PC.

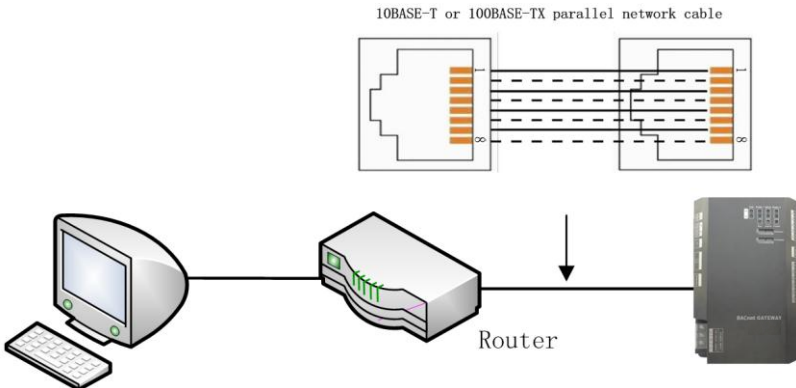

(2) Communication line connection between BACnet gateway and AC units:

When gateway is connected to main control unit of ODU, ODU with the address dial-up of 0 must be connected.

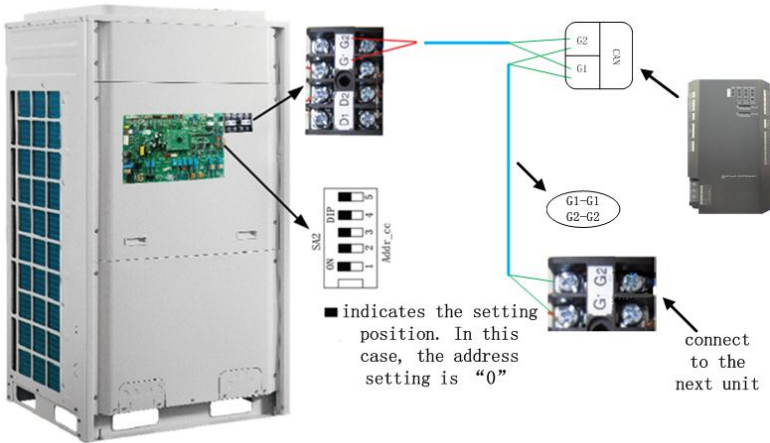

(3) BACnet gateway configuration:

One BACnet gateway connects 16 systems and 255 IDUs at the same time. The gateway parameter shall be configured after its installation, however, before this please set the IP address of the PC the same with that of the BACnet gateway, see Attachment A; then open browser(IE10 or higher, Firefox or Google), input the default IP address into the address field: <http://192.168.1.150>, the default user name and password are both "config"; refer to the following fig.

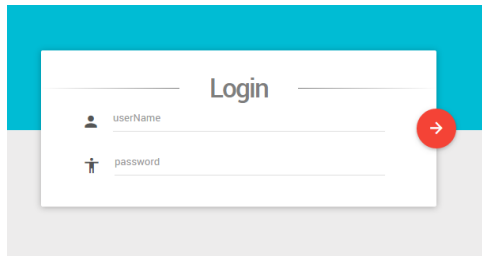

After input, press the button to go to the setting page.

The configurable parameters include BACnet gateway IP address, gateway subnet mask code, default gateway, gateway name, gateway ID. The user can conduct configuration at his will, after that, click button and it will take effect after resarted Gateway.

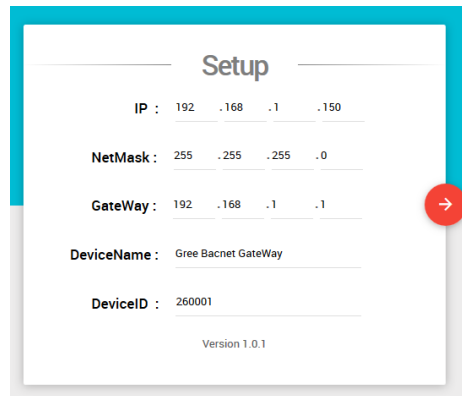

6 BACnet protocol

6.1 Structure of BACnet protocol

The structure of BACnet standard protocol is specific to building self-control system characteristics, a simplified 4-layer structure from OSI 7-layer structure; this 4-layer is corresponding to the application layer, network layer, data link and physical layer in OSI model. BACnet standard protocol defines its application layer and network layer, and provides the following 5 solutions to its data link and physical layers.

BACnet Layers				Equivalent OSI Layers
BACnet Application Layer				Application
BACnet Network Layer				Network
ISO8802-2 (IEEE802.2) Type1	MS/TP	PTP	LonTalk	Data Link
ISO8802-3 (IEEE802.3)	ARCNET	EIA-485 (RS485)		EIA-232 (RS232)

6.2 Object and property of BACnet protocol

6.2.1 Definition of BACnet object

BACnet defines a group of objects with property to represent any functions of building self-control equipment, thus provide a standard method to represent building self-control equipment. The BACnet gateway defines 9 objects, the enumeration number, name and application sample of these objects are introduced as follows.

No.	Object name	Application sample
0	Analog Input	Sensor input
1	Analog Output	Control output
2	Analog Value	The set valve value or other analog control system parameter
3	Binary Input	Switch input
4	Binary Output	Relay output
5	Binary Value	Digital control system parameter
13	Multi-state Input	Indicate a multi-state processing program situation, such as open/close refrigerator and defrosting cycle etc.
14	Multi-state Output	Indicate a multi-state processing program expectation status, e.g. started cooling time for refrigerator.
19	Multi-state Value	Indicate a multi-state processing program parameter, such as AC fan speed setting and mode setting, etc.

Each object has a set of property, the property value describes the features and functions of the objects.

6.2.2 Table of BACnet protocol point

One BACnet object ID is consist of the following 5 parts:

BACnet object ID (32bits)				
10 bits	3 bits	2 bits	9 bits	8 bits
Object type(T)	Model series (assigned to be 0)(M)	Equipment type(01,02,03)(D)	Equipment migration(N)	Parameter No.(P)

Object type: it indicates the BACnet object type, like AI, BO, etc, among which, T means the enumeration number of AI and BO.

Equipment type: include the gateway itself (0), IDU(1), ODU(2) and IO module(3).

Equipment migration: for IDU object, it means the IDU No.;

Parameter number: the sequence of parameter number after data conversion;

ID value of BACnet object:

$$\text{BACnet ID} = P + N * 256 + D * 256 * 512 + M * 256 * 512 * 4 + T * 256 * 512 * 32;$$

For example indoor ambient temperature of object

(IndoorUnitAmbientTemp_01_01_01) , its BACnet object ID is

(IndoorUnitAmbientTemp_01_01_01) with the following meaning:

BACnet object ID(32bits)				
10 bits	3 bits	2 bits	9 bits	8 bits
Object type(T)	Model series (assigned to be 0)(M)	Equipment type(01,02,03)(D)	Equipment migration(N)	Parameter No.(P)
0: AI	0: Multi VRF	1:IDU	1	1

If the value of initial IDU engineering code object (FirstIndoorUnitNum_01_00_00 with object ID of 1) of this BACnet gateway is M, then IndoorUnitAmbientTemp_01_01_01 (131329) represents a IDU parameter with the engineering code of (M+1).

Attachment A Parameter of air conditioner (Protocol version V1.0.0)

Equipment	Object type	Parameter name	Instance No.	Current value
IDU	Indoor ambient temperature	AI	(N-1)*256+131072	Actual value:-30~138;
	Temperature setting	AV	(N-1)*256+131072	Actual value:16.0~30.0;
	Lower limit temperature setting for cooling energy saving	AV	(N-1)*256+131073	Actual value:16.0~30.0;
	Lower limit temperature setting for heating energy saving	AV	(N-1)*256+131074	Actual value:16.0~30.0;
	Lower limit temperature setting for dehumidifying energy saving	AV	(N-1)*256+131075	Actual value:16.0~30.0;
	With IDU or not	BI	(N-1)*256+131072	0: No, 1: Yes
	Other malfunctions	BI	(N-1)*256+131073	0: No, 1: Yes
	Communication error between gateway and IDU	BI	(N-1)*256+131074	0: No, 1: Yes
	IDU general error	BI	(N-1)*256+131075	0: No, 1: Yes
	IDU protection	BI	(N-1)*256+131076	0: No, 1: Yes
	Indoor fan protection	BI	(N-1)*256+131077	0: No, 1: Yes
	Full water protection	BI	(N-1)*256+131078	0: No, 1: Yes
	Power supply overload protection	BI	(N-1)*256+131079	0: No, 1: Yes
	Anti freezing protection	BI	(N-1)*256+131080	0: No, 1: Yes
	Mode conflict	BI	(N-1)*256+131081	0: No, 1: Yes
	Malfunction of indoor circuit board	BI	(N-1)*256+131082	0: No, 1: Yes
	IDU temperature sensor malfunction	BI	(N-1)*256+131083	0: No, 1: Yes
	Ambient temperature sensor malfunction	BI	(N-1)*256+131084	0: No, 1: Yes
	Inlet temperature sensor malfunction	BI	(N-1)*256+131085	0: No, 1: Yes
	Outlet temperature sensor malfunction	BI	(N-1)*256+131086	0: No, 1: Yes
	Humidity sensor malfunction	BI	(N-1)*256+131087	0: No, 1: Yes
Communication malfunction	BI	(N-1)*256+131088	0: No, 1: Yes	
Engineering number conflict of IDU	BI	(N-1)*256+131089	0: No, 1: Yes	
Missing main IDU	BI	(N-1)*256+131090	0: No, 1: Yes	

BACnet Gateway Owner's Manual

Equipment	Object type	Parameter name	Instance No.	Current value
	One controller for multiple units, and the number of IDU is inconsistent (HBS)	BI	(N-1)*256+131091	0: No, 1: Yes
	Main mode of IDU/subordinate mode of IDU	BI	(N-1)*256+131092	0: Slave IDU, 1: Master IDU
	Auxiliary electrical heating of IDU	BI	(N-1)*256+131093	0: Off, 1: On
	ON/OFF	BV	(N-1)*256+131072	0: Off, 1: On
	Energy saving setting	BV	(N-1)*256+131073	0: Off, 1: On
	Long distance shield energy saving function	BV	(N-1)*256+131074	0: No shield, 1: Shield
	Long distance shield temperature setting function	BV	(N-1)*256+131075	0: No shield, 1: Shield
	Long distance shield mode function	BV	(N-1)*256+131076	0: No shield, 1: Shield
	Long distance shield on/off function	BV	(N-1)*256+131077	0: No shield, 1: Shield
	Long distance lock function	BV	(N-1)*256+131078	0: Unlock, 1: Lock
	IDU memory	BV	(N-1)*256+131079	0: Standby, 1: Power-failure memory
	Give priority to IDU when supplying power	BV	(N-1)*256+131080	0: No, 1: Yes
	8°C heating function setting	BV	(N-1)*256+131081	0: Cancel 8°C heating, 1: Start 8°C heating
	Dry	BV	(N-1)*256+131082	0: Off, 1: On
	Ventilation	BV	(N-1)*256+131083	0: Off, 1: On
	Shield ON	BV	(N-1)*256+131084	0: No shield, 1: Shield
	Shield OFF	BV	(N-1)*256+131085	0: No shield, 1: Shield
	Shield timer	BV	(N-1)*256+131086	0: No shield, 1: Shield
	Forbid opening auxiliary heating	BV	(N-1)*256+131087	0: Cancel low-temperature dehumidification, 1: Start low-temperature dehumidification
	Dehumidifying under low temperature	BV	(N-1)*256+131088	0: Auxiliary heating is allowable, 1: Auxiliary heating is not allowable
	Cancel filter cleaning remind	BV	(N-1)*256+131089	0: No, 1: Yes
	All IDUs open	BO	(N-1)*256+131072	0: Invalid, 1: All on
	All IDUs closed	BO	(N-1)*256+131073	0: All off; 1: Invalid
	The subordinated ODU No. of IDU	MI	(N-1)*256+131072	Actual value: 1-16
	Rated capacity of IDU	AI	(N-1)*256+131073	Actual value(KW): 2.2;2.5;2.8;3.2;3.6;4.0;4.5;5.0; 5.6; 6.3;7.1;8.0;9.0;10.0;11.2;12.5; 14.0;1 6.0;18.0;22.4;25.0;28.0;33.5;3 5.0;40.0;45.0;50.0;56.0;

Equipment	Object type	Parameter name	Instance No.	Current value
	Gate control status	MI	(N-1)*256+131073	Actual value: 0:Invalid; 1:Without door control; 2: Card is inserted; 3:Card is disconnected
	Operation mode setting	MV	(N-1)*256+131072	Actual value: 0:Invalid; 1:Cooling; 2:Dehumidifying; 3:Fan; 4:Heating; 5:Auto; 6:Floor heating; 7:Rapid heating; 8:Heat supply
	Fan speed setting	MV	(N-1)*256+131073	Actual value: 0:Invalid; 1:Auto fan speed; 2:Low; 3:Medium-low; 4:Medium; 5:Medium-high;6:High; 7:Turbo
	Vertical swing	MV	(N-1)*256+131074	Range: 0~255; 0:Invalid; 1:Off; 2:15 swing; 3:1 position; 4:2 position; 5:3 position; 6:4 position; 7:5 position; 8:35 swing; 9:23 swing; 10:24 swing; 11:14 swing; 12:13 swing; others are reserved
	Horizontal swing	MV	(N-1)*256+131075	Range: 0~255; 0:Invalid; 1:Off; 2:Homodromous swing; 3:1 position; 4:2 position; 5:3 position; 6:4 position; 7:5 position; 13:15 position; 14:Opponent swing; others are reserved
	Quiet	MV	(N-1)*256+131076	Range: 0:Invalid data; 1:Quiet off; 2:Auto quiet;3:Quiet
	Sleep	MV	(N-1)*256+131077	Range: 0:Invalid data; 1:Sleep off; 2:Sleep 1; 3:Sleep 2; 4:Sleep 3
ODU	Outdoor ambient temperature	AI	(N-1)*256+262144	Actual value:-30~155
	Module 1 effective value of power grid side phase voltage	AI	(N-1)*256+262145	Actual value(V):0~510
	Module 1 PV DC bus voltage	AI	(N-1)*256+262146	Actual value(V):0~65535
	Module 1 power grid side current	AI	(N-1)*256+262147	Actual value(A)
	Module 1 power grid side grid connection power	AI	(N-1)*256+262148	Actual value(KW):-327.68~327.67
	Module 1 PV power	AI	(N-1)*256+262149	Actual value(KW):0~655.35
	Module 1 quantity of side grid connection	AI	(N-1)*256+262150	Actual value(KWH):-9.102~9.102

BACnet Gateway Owner's Manual

Equip ment	Object type	Paramet er name	Instance No.	Current value
	Module 1 quantity of PV power generation	AI	(N-1)*256+262151	Actual value(KWH):0~18.204
	Module 1 PV side input current	AI	(N-1)*256+262152	Actual value(A)
	Module 2 effective value of power grid side phase voltage	AI	(N-1)*256+262153	Actual value(V):0~510
	Module 2 PV DC bus voltage	AI	(N-1)*256+262154	Actual value(V):0~65535
	Module 2 power grid side current	AI	(N-1)*256+262155	Actual value(A)
	Module 2 power grid side grid connection power	AI	(N-1)*256+262156	Actual value(KW):-327.68~327.67
	Module 2 PV power	AI	(N-1)*256+262157	Actual value(KW):0~655.35
	Module 2 quantity of side grid connection	AI	(N-1)*256+262158	Actual value(KWH):-9.102~9.102
	Module 2 quantity of PV power generation	AI	(N-1)*256+262159	Actual value(KWH):0~18.204
	Module 2 PV side input current	AI	(N-1)*256+262160	Actual value(A)
	Module 3 effective value of power grid side phase voltage	AI	(N-1)*256+262161	Actual value(V):0~510
	Module 3 PV DC bus voltage	AI	(N-1)*256+262162	Actual value(V):0~65535
	Module 3 power grid side current	AI	(N-1)*256+262163	Actual value(A)
	Module 3 power grid side grid connection power	AI	(N-1)*256+262164	Actual value(KW):-327.68~327.67
	Module 3 PV power	AI	(N-1)*256+262165	Actual value(KW):0~655.35
	Module 3 quantity of side grid connection	AI	(N-1)*256+262166	Actual value(KWH):-9.102~9.102
	Module 3 quantity of PV power generation	AI	(N-1)*256+262167	Actual value(KWH):0~18.204
	Module 3 PV side input current	AI	(N-1)*256+262168	Actual value(A)
	Module 4 effective value of power grid side phase voltage	AI	(N-1)*256+262169	Actual value(V):0~510
	Module 4 PV DC bus voltage	AI	(N-1)*256+262170	Actual value(V):0~65535
	Module 4 power grid side current	AI	(N-1)*256+262171	Actual value(A)
	Module 4 power grid side grid connection power	AI	(N-1)*256+262172	Actual value(KW):-327.68~327.67
	Module 4 PV power	AI	(N-1)*256+262173	Actual value(KW):0~655.35
	Module 4 quantity of side grid connection	AI	(N-1)*256+262174	Actual value(KWH):-9.102~9.102
	Module 4 quantity of PV power generation	AI	(N-1)*256+262175	Actual value(KWH):0~18.204
	Module 4 PV side input current	AI	(N-1)*256+262176	Actual value(A)
	Module 1 percentage setting for PV side limit power	AV	(N-1)*256+262144	Actual value(%)
	Module 2 percentage setting for PV side limit power	AV	(N-1)*256+262145	Actual value(%)
	Module 3 percentage setting for PV side limit power	AV	(N-1)*256+262146	Actual value(%)
	Module 4 percentage setting	AV	(N-1)*256+262147	Actual value(%)

Equipment	Object type	Parameter name	Instance No.	Current value
	for PV side limit power			
	Communication malfunction between gateway and ODU	BI	(N-1)*256+262144	0: No, 1: Yes
	With ODU or not	BI	(N-1)*256+262145	0: No, 1: Yes
	Other malfunctions	BI	(N-1)*256+262146	0: No, 1: Yes
	Back flow protection for 4-way valve	BI	(N-1)*256+262147	0: No, 1: Yes
	Pressure ratio is abnormal	BI	(N-1)*256+262148	0: No, 1: Yes
	High pressure protection	BI	(N-1)*256+262149	0: No, 1: Yes
	Low pressure protection	BI	(N-1)*256+262150	0: No, 1: Yes
	High discharge temperature protection	BI	(N-1)*256+262151	0: No, 1: Yes
	Overload protection	BI	(N-1)*256+262152	0: No, 1: Yes
	Communication malfunction	BI	(N-1)*256+262153	0: No, 1: Yes
	Outdoor ambient temperature sensor malfunction	BI	(N-1)*256+262154	0: No, 1: Yes
	Discharge sensor fall-off malfunction	BI	(N-1)*256+262155	0: No, 1: Yes
	High pressure sensor malfunction	BI	(N-1)*256+262156	0: No, 1: Yes
	Low pressure sensor malfunction	BI	(N-1)*256+262157	0: No, 1: Yes
	Discharge sensor malfunction	BI	(N-1)*256+262158	0: No, 1: Yes
	Capacity match abnormal	BI	(N-1)*256+262159	0: No, 1: Yes
	Defrosting sensor malfunction	BI	(N-1)*256+262160	0: No, 1: Yes
	Subcooler sensor malfunction	BI	(N-1)*256+262161	0: No, 1: Yes
	Vapour separator sensor malfunction	BI	(N-1)*256+262162	0: No, 1: Yes
	Fan drive board malfunction	BI	(N-1)*256+262163	0: No, 1: Yes
	Compressor drive board malfunction	BI	(N-1)*256+262164	0: No, 1: Yes
	Compressor drive board working abnormal	BI	(N-1)*256+262165	0: No, 1: Yes
	Voltage protection for compressor drive board power	BI	(N-1)*256+262166	0: No, 1: Yes
	Fan drive board working abnormal	BI	(N-1)*256+262167	0: No, 1: Yes
	Voltage protection for fan drive board power	BI	(N-1)*256+262168	0: No, 1: Yes
	Module 1 malfunction	BI	(N-1)*256+262169	0: No, 1: Yes
	Module 2 malfunction	BI	(N-1)*256+262170	0: No, 1: Yes
	Module 3 malfunction	BI	(N-1)*256+262171	0: No, 1: Yes
	Module 4 malfunction	BI	(N-1)*256+262172	0: No, 1: Yes
	High pressure over low protection	BI	(N-1)*256+262173	0: No, 1: Yes
	Unrecoverable malfunction in ODU system	BI	(N-1)*256+262174	0: No, 1: Yes

BACnet Gateway Owner's Manual

Equipment	Object type	Parameter name	Instance No.	Current value
	Recoverable malfunction in ODU system	BI	(N-1)*256+262175	0: No, 1: Yes
	Discharge temperature over low protection	BI	(N-1)*256+262176	0: No, 1: Yes
	Pressure sensor malfunction	BI	(N-1)*256+262177	0: No, 1: Yes
	General malfunction of ODU	BI	(N-1)*256+262178	0: No, 1: Yes
	Compressor operation status	BI	(N-1)*256+262179	0: Off, 1: On
	Unit debugging status	BI	(N-1)*256+262180	0: Normal, 1: Debug
	Start electricity VIP mode	BI	(N-1)*256+262181	0: No, 1: Yes
	Module 1 side grid connection status ON/OFF of power grid	BI	(N-1)*256+262182	0: Off, 1: On
	Module 1 MPPT ON/OFF status	BI	(N-1)*256+262183	0: Off, 1: On
	Module 1 percentage setting for PV side limit power	BI	(N-1)*256+262184	0: Normal, 1: Limit frequency
	Module 1 mark of electric quantity statistics	BI	(N-1)*256+262185	0: Power calculation is not done, 1: Power calculation is done
	Module 2 side grid connection status ON/OFF of power grid	BI	(N-1)*256+262186	0: Off, 1: On
	Module 2 MPPT ON/OFF status	BI	(N-1)*256+262187	0: Off, 1: On
	Module 2 percentage setting for PV side limit power	BI	(N-1)*256+262188	0: Normal, 1: Limit frequency
	Module 2 mark of electric quantity statistics	BI	(N-1)*256+262189	0: Power calculation is not done, 1: Power calculation is done
	Module 3 side grid connection status ON/OFF of power grid	BI	(N-1)*256+262190	0: Off, 1: On
	Module 3 MPPT ON/OFF status	BI	(N-1)*256+262191	0: Off, 1: On
	Module 3 percentage setting for PV side limit power	BI	(N-1)*256+262192	0: Normal, 1: Limit frequency
	Module 3 mark of electric quantity statistics	BI	(N-1)*256+262193	0: Power calculation is not done, 1: Power calculation is done
	Module 4 side grid connection status ON/OFF of power grid	BI	(N-1)*256+262194	0: Off, 1: On
	Module 4 MPPT ON/OFF status	BI	(N-1)*256+262195	0: Off, 1: On
	Module 4 percentage setting for PV side limit power	BI	(N-1)*256+262196	0: Normal, 1: Limit frequency
	Module 4 mark of electric quantity statistics	BI	(N-1)*256+262197	0: Power calculation is not done, 1: Power calculation is done
	ODU remote control emergency stop	BV	(N-1)*256+262144	0: No, 1: Yes. Note: apply to CAN2 only
	Remote energy saving mark	BV	(N-1)*256+262145	0: Off, 1: On. Note: apply to CAN2 only

Equipment	Object type	Parameter name	Instance No.	Current value
	Cooling/heating mode of the whole unit	MI	(N-1)*256+262144	Actual value: 0:Invalid; 1:Cooling only; 2:Heating 3:Cooling and heating; 4:Fan
	Emergency operation mode	MI	(N-1)*256+262145	Actual value: 1:No emergency operation; 2:Emergency operation of compressor; 3:Emergency operation of fan; 4:Emergency operation of module
	Upper limit setting of ODU capacity	MV	(N-1)*256+262144	Actual value(%):30~100. Note: apply to CAN2 only
IO	DI point 1 (fire signal)	BI	393216	0: Off、1: On. Note: CAN2 remote control emergency stop, CAN1 to shut down all IDUs
	DI point 2	BI	393217	0: Off、1: On
	DI point 3	BI	393218	0: Off、1: On
	DI point 4	BI	393219	0: Off、1: On
	DI point 5	BI	393220	0: Off、1: On
	D0 point 1	BV	393216	0: Off、1: On
	D0 point 2	BV	393217	0: Off、1: On
	D0 point 3	BV	393218	0: Off、1: On
	D0 point 4	BV	393219	0: Off、1: On
D0 point 5	BV	393220	0: Off、1: On	

Note: Engineering code N of IDU is 1~255, and engineering code N of ODU (modular) is 1~16.

Attachment B TCP/IP setting

Take Windows 7 as an example to demonstrate the configuration process of TCP/IP.

(1) Conduct property configuration of local connection.

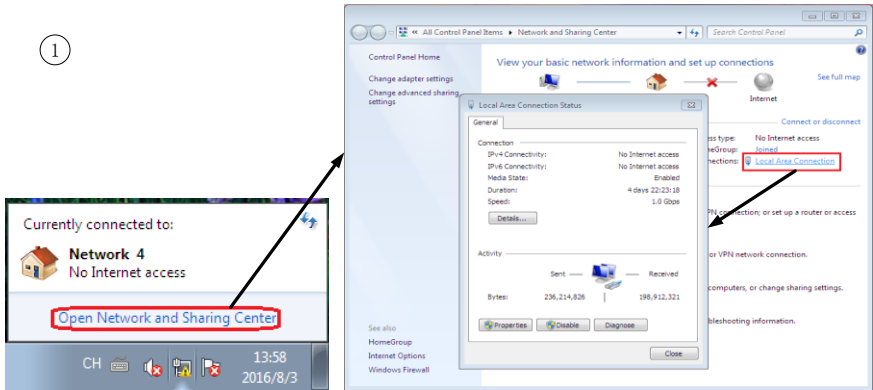

(2) Choose the item: Internet protocol (TCP/IP).

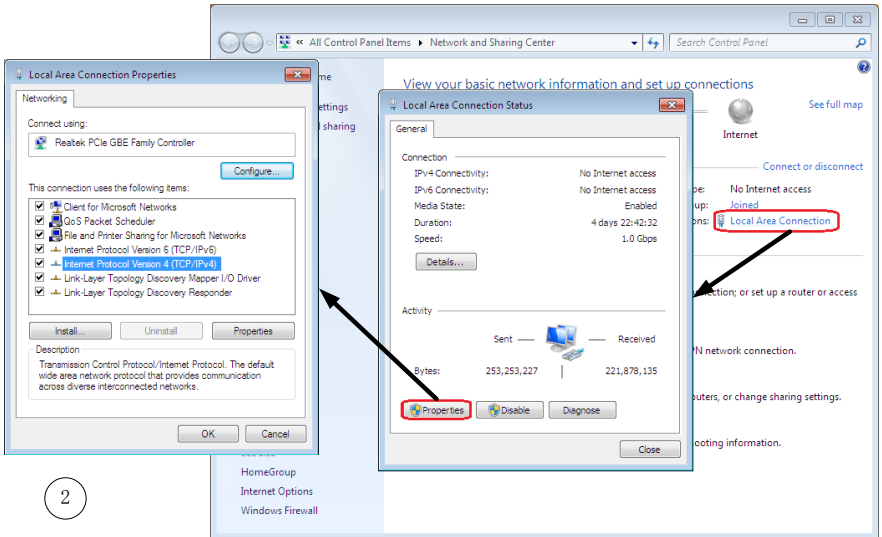

(3) Conduct TCP/IP property setting as shown in the fig.

(4) No additional configuration for DNS server, computer default setting can be retained

(5) Click "Yes" to complete the configuration.

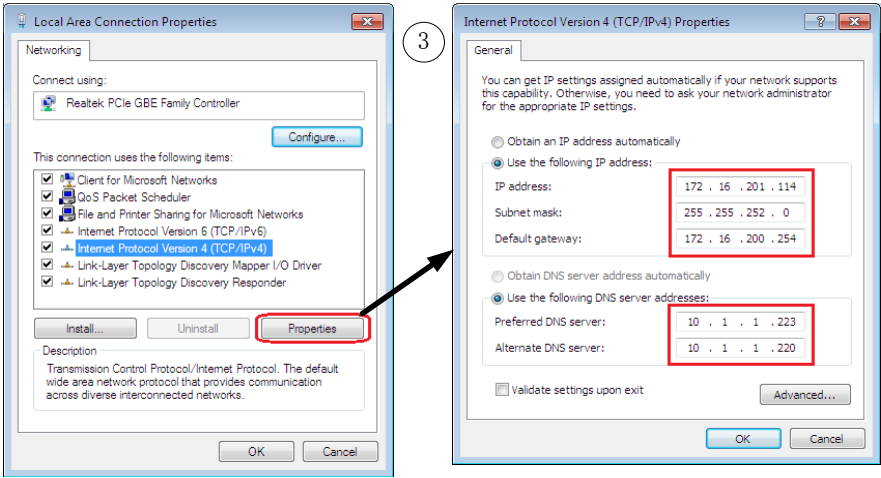

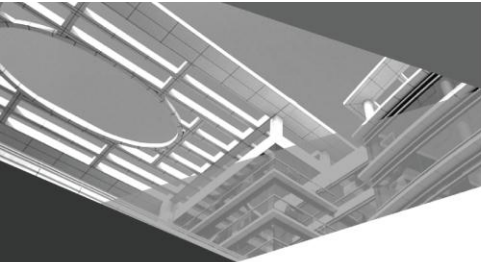

GREE ELECTRIC APPLIANCES, INC. OF ZHUHAI

Add: West Jinji Rd, Qianshan, Zhuhai, Guangdong, China, 519070

Tel: (+86-756) 8522218

Fax: (+86-756) 8669426

E-mail: gree@gree.com.cn www.gree.com



600005000323