



Owner's Manual

Original Instructions
Commercial Air Conditioners

DC Inverter Multi VRF System

Models:

AMV6-O224

AMV6-O280

AMV6-O335

.....

AMV6-O2460

Thank you for choosing commercial air conditioners. Please read this Owner's Manual carefully before operation and retain it for future reference.

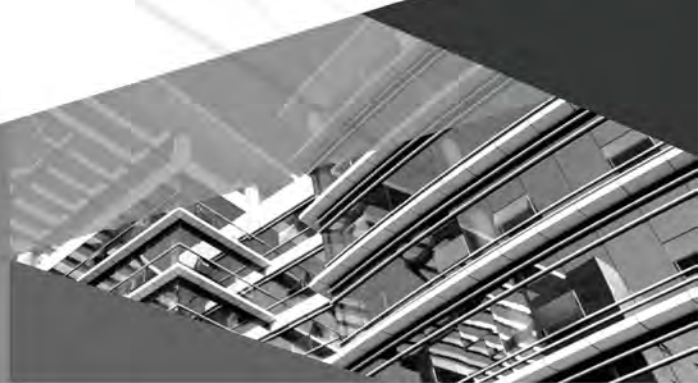

To Users

Thank you for selecting our product. Please read this instruction manual carefully before installing and using the product, so as to master and correctly use the product. In order to guide you to correctly install and use our product and achieve expected operating effect, we hereby instruct as below:

- (1) This appliance can be used by children aged from 8 years and above and persons with reduced physical, sensory or mental capabilities or lack of experience and knowledge if they have been given supervision or instruction concerning use of the appliance in a safe way and understand the hazards involved. Children shall not play with the appliance. Cleaning and user maintenance shall not be made by children without supervision.
- (2) In order to ensure reliability of product, the product may consume some power under stand-by status for maintaining normal communication of system and preheating refrigerant and lubricant. If the product is not to be used for long, cut off the power supply; please energize and preheat the unit in advance before reusing it.
- (3) Please properly select the model according to actual using environment; otherwise it may impact the using convenience.
- (4) This product has gone through strict inspection and operational test before leaving the factory. In order to avoid damage due to improper disassembly and inspection, which may impact the normal operation of unit, please do not disassemble the unit by yourself. You can contact with the special maintenance center of our company if necessary.
- (5) When the product is faulted and cannot be operated, please contact with our maintenance center as soon as possible by providing the following information.
 - 1) Contents of nameplate of product (model, cooling/heating capacity, product No., ex-factory date).
 - 2) Malfunction statuses (specify the situations before and after the error occur).
- (6) All the illustrations and information in the instruction manual are only for reference. In order to make the product better, we will continuously conduct improvement and innovation. We have the right to make necessary revision to the product from time to time due to the reason of sales or production, and reserve the right to revise the contents without further notice.
- (7) The final right to interpret for this instruction manual belongs to ASAMI.

Exception Clauses





Manufacturer will bear no responsibilities when personal injury or property loss is caused by the following reasons:

- (1) Damage the product due to improper use or misuse of the product;
- (2) Alter, change, maintain or use the product with other equipment without abiding by the instruction manual of manufacturer;
- (3) After verification, the defect of product is directly caused by corrosive gas;
- (4) After verification, defects are due to improper operation during transportation of product;
- (5) Operate, repair, maintain the unit without abiding by instruction manual or related regulations;
- (6) After verification, the problem or dispute is caused by the quality specification or performance of parts and components that produced by other manufacturers;
- (7) The damage is caused by natural calamities, bad using environment or force majeure.

Contents

1 Safety Notices (Please be sure to abide)	1
2 Product Introduction	5
2.1 Product Features	5
2.2 Product List	5
2.3 Names of Main Parts	7
2.4 The Range of Production Working Temperature	8
2.5 Standard Parts	8
3 Product Installation	8
3.1 Safety Precautions for Installing, Repairing and Moving Units	8
3.2 Outdoor Unit Installation	10
3.3 Pipeline Design.....	19
3.4 Pipeline Installation and Insulation.....	26
3.5 Static Pressure Ventilation Pipe Installation	31
3.6 Vacuum and Drying of Refrigeration System.....	33
3.7 Additional Refrigerant Charging	35
3.8 Electrical Installation	39
3.9 Communication Line Connection	44
3.10 Check Items after Installation.....	50
4 Debugging and Operation	51
4.1 Preparation before Test Run	51
4.2 Notices for Unit Debugging	52
4.3 Basic Introduction for Engineering Debugging	55
5 Operation Instruction	62
6 Maintenance	62
6.1 Heat Exchanger of Outdoor Unit.....	62
6.2 Drain Pipe.....	62
6.3 Precautions at the Beginning of Using Season	63
6.4 Maintenance at the End of Using Season	63
6.5 Parts Replacement	63
7 Troubleshooting	63
7.1 Common Malfunction and Troubleshooting.....	63
7.2 Error Indication	65
8 After-sales Service	69

1 Safety Notices (Please be sure to abide)

	WARNING: If not abide them strictly, it may cause severe damage to the unit or the people.
	NOTICE: If not abide them strictly, it may cause slight or medium damage to the unit or the people.
	This sign indicates that the operation must be prohibited. Improper operation may cause severe damage or death to people.
	This sign indicates that the items must be observed. Improper operation may cause damage to people or property.



WARNING!

- This product can't be installed at corrosive, inflammable or explosive environment or the place with special requirements, such as kitchen. Otherwise, it will affect the normal operation or shorten the service life of the unit, or even cause fire hazard or serious injury. As for the above special places, please adopt special air conditioner with anti-corrosive or anti-explosion function.
- A warning to assure that partial units shall only be connected to an appliance suitable for the same refrigerant.
- Follow this instruction to complete the installation work. Please carefully read this manual before unit startup and service.
- This unit <model xxx> is a partial unit air conditioner, complying with partial unit requirements of this International Standard, and must only be connected to other units that have been confirmed as complying to corresponding partial unit requirements of this International Standard.
- Installation should be conducted by dealer or qualified personnel. Please do not attempt to install the unit by yourself. Improper handling may result in water leakage, electric shock or fire disaster etc.
- Before using the unit, please check if the pipe and wiring are correct to avoid water leakage, refrigerant leakage, electric shock, or fire etc.
- Don't climb the outdoor unit, and don't put anything on it. If you fall or turn it over, it will cause damage.
- Before performing related operations (such as maintenance, inspection, etc.) for the equipment, the unit must be turned off and the power supply must be cut off. Moreover, use the relevant instrument check whether the voltage at the power input terminal is zero. After that, you can perform the operation. Otherwise it will cause electric shock or injury (the unit has low-power standby function. Only the main control board indicator is on under standby status).
- If conducting troubleshooting or maintenance for the modular unit, all outdoor units are required to be de-energized or energized at the same time. It's prohibited to energize or de-energize some outdoor units.

- If anything abnormal happens (such as burning smell), please power off the unit and cut off the main power supply, and then immediately contact ASAMI appointed service center. If abnormality keeps going, the unit might be damaged and lead to electric shock or fire.
- After connecting the power cord, please fix the electric box cover properly in order to avoid accident.
- Be sure to use the exclusive accessory and part to prevent the water leakage, electric shock and fire accidents.
- Make sure the unit can be earthed properly and soundly after plugging into the socket so as to avoid electric shock. Please do not connect the ground wire to gas pipe, water pipe, lightning rod or telephone line.
- The leakage circuit breaker must be installed. If not, it may cause electric shock or Fire.
- If refrigerant leakage happens during installation, please ventilate immediately. Poisonous gas will emerge if the refrigerant gas meets fire.
- Refrigerant gas is heavier than air and oxygen, especially in the basement. A large amount of refrigerant leakage will cause the decrease in oxygen and then cause suffocation, which will affect the health of people.
- After all installations are completed, check whether there's refrigerant leakage.
- Do not install the unit in a flammable place. Otherwise, it will cause an explosion and affect the health of people.
- Disposal of packaging, transportation materials and other parts must comply with the relevant regulations of the local country.



NOTES!

- Before installation, please check if the power supply is in accordance with the requirements specified on the nameplate. And also take care of the power safety.
- Turn off the unit after it runs at least five minutes; otherwise it will influence oil return of the compressor.
- Electrify the unit 2 hours before operation. Please switch on for 2 hours before operation. Do not cut off the power when 24 hours short-time halting (to protect the compressor).
- The air conditioner should be grounded, and the power outlet must be equipped with a ground wire to ensure that the air conditioner is effectively grounded through the power socket to avoid the risk of electric shock.
- Under cooling mode, please don't set the room temperature too low.
- When the air conditioner is installed in a small room, take the necessary measures to avoid the concentration of the refrigerant exceeding the limit value for safety.
- When the external temperature is decreased, the heating performance of the unit will be decreased. If so, please use another heating device for heating at the same time. (When you use a heating device with open fire in the same room, please always open the door or window to keep the air circulation and avoid the lack of oxygen in the room.) Please do not put the heating device with open fire at the air outlet, or put it under the air conditioner.

- When the unit is turned on for heating, it takes time for the room temperature to rise because the unit uses hot air circulation to heat the entire room.
- Open the door and window and keep good ventilation in the room to avoid oxygen deficit when the gas/oil supplied heating equipment is used.
- Volatile liquid, such as diluent or gas will damage the unit appearance. Only use soft cloth with a little neutral detergent to clean the outer casing of unit.
- Install the air conditioner in a solid place that can withstand its weight. Fully consider the influence of strong winds, typhoons and earthquakes and reinforced installation. Improper installation will cause the air conditioning unit to fall and then cause injury.
- Please use the electric wire with specified specifications. Electrical installation work must comply with local laws and regulations. Insufficient capacity or improper electrical operation can cause electric shock or fire.
- All electric wires must be confirmed to be connected well so that the wiring terminals and electrical wires are not pulled by external force. Improper installation may cause fire.
- After connecting the power cord, please fix the electric box cover properly in order to avoid accident.
- After confirming that the unit's power is off, you can touch the electrical components of the unit, otherwise it will cause electric shock.
- Do not modify the unit protection settings. If a pressure switch, end switch or other protective device is short-circuited and forced to operate, it may cause a fire or explosion.
- When installing the unit, make sure that the connection pipe is securely connected before starting up the compressor. If the compressor is started up before the connection of the connecting pipe is completed and the shut-off valve is opened, mixed air will cause the system pressure to rise, which may cause compressor bursting accident and injury.
- Heat exchanger fins are sharp. You may be injured if used it incorrectly. Please wear the gloves to avoid injury.
- Do not directly touch the refrigerant pipes during the operation and when the operation is finished just now, including refrigerant pipes, compressors, and other refrigerant circulation pipes. These pipes are hot and cold. It will scald and frostbite if directly contacts them. To avoid injury, please wait until the pipes reach to normal temperature. Please wear gloves when you must touch it.
- Improper installation of drain pipes can result in water leakage and poor function.
- R410A is a mixture. The refrigerant must be filled from the liquid pipe. If the refrigerant is filled from the gas pipe, the composition of the refrigerant will change and the system can't operate normally.
- Take adequate measures to prevent small animals from making nests in the unit. Once small animals touch electrical components, it may cause malfunction or fire hazard. Remind customers to clean around the unit.

- The installed indoor unit, outdoor unit, power cord and connection wire must be at least 1m away from the TV or radio to avoid image interference or noise. If the radio wave is strong, sometimes even if the distance is more than 1 m, it is not enough to avoid interference.
- When disassembling the unit, handling refrigerants, oil and other components of the unit, it must be in accordance with the relevant national/continental regulations.
- Air conditioning units or heat pump units are appliances which are not easily accessible to the public.
- The design pressure is 4.3 MPa. The thickness of pipe for installation should comply with the relevant national/continental regulations.
- After the power cord is installed, please note to ensure that the power cord should not direct touch the sheet metal of electric box.



NEVER TO DO

- Never start up or shut off the air conditioner by means of directly plug or unplug the power cord.
- Do not insert fingers or objects into air outlet/inlet grille.
- Do not operate this unit with wet hands.
- Never short-circuit or cancel the pressure switch to prevent unit damage.
- Never fail to comply with the nitrogen charge requirements. Charge nitrogen when welding pipes.
- Never spray or flush water towards unit, otherwise malfunction or electric shock may happen.
- Never allow children to play around or on the top of the unit, otherwise injury may happen.



MUST TO DO

- User is not allowed to repair the unit. Fault service may cause electric shock or fire accidents. Please contact ASAMI appointed service center for help.
- Do not expose the unit to the moist or corrosive circumstances.
- Do not directly touch the refrigerant leaking from the refrigerant pipe connection place, as it may cause frostbite.
- Please firstly connect the wired controller before energizing, otherwise wired controller can't be used.
- The power cable diameter should be big enough. If the power cord and connection wire are damaged, they must be replaced with the special cables.
- Once all installations are completed, check whether there is refrigerant leakage.

2 Product Introduction

2.1 Product Features

ASAMI Multi VRF Modular System adopts inverter compressor technology. According to change the displacement of compressor, stepless capacity regulation within range of 10%-100% can be realized. Various product lineup is provided with capacity range from 22.4kW to 246kW, which can be widely used in working area and especially applicable to the place with variable load change.

2.2 Product List

2.2.1 Combinations of Outdoor Units

Model	AMV6-O224	AMV6-O280	AMV6-O335	AMV6-O400	AMV6-O450	AMV6-O504	AMV6-O560	AMV6-O615
AMV6-O224	◆							
AMV6-O280		◆						
AMV6-O335			◆					
AMV6-O400				◆				
AMV6-O450					◆			
AMV6-O504						◆		
AMV6-O560							◆	
AMV6-O615								◆
AMV6-O680		◆		◆				
AMV6-O730		◆			◆			
AMV6-O784		◆				◆		
AMV6-O840		◆					◆	
AMV6-O895		◆						◆
AMV6-O950			◆					◆
AMV6-O1015				◆				◆
AMV6-O1065					◆			◆
AMV6-O1119						◆		◆
AMV6-O1175							◆	◆
AMV6-O1230								◆◆
AMV6-O1290		◆			◆		◆	

DC Inverter Multi VRF System

Model	AMV6-O224	AMV6-O280	AMV6-O335	AMV6-O400	AMV6-O450	AMV6-O504	AMV6-O560	AMV6-O615
AMV6-O1345		◆			◆			◆
AMV6-O1400			◆		◆			◆
AMV6-O1455		◆					◆	◆
AMV6-O1510		◆						◆◆
AMV6-O1565			◆					◆◆
AMV6-O1630				◆				◆◆
AMV6-O1680					◆			◆◆
AMV6-O1734						◆		◆◆
AMV6-O1790							◆	◆◆
AMV6-O1845								◆◆◆◆
AMV6-O1905		◆			◆		◆	◆
AMV6-O1959		◆				◆	◆	◆
AMV6-O2015		◆					◆◆	◆
AMV6-O2070		◆					◆	◆◆
AMV6-O2125		◆						◆◆◆◆
AMV6-O2180			◆					◆◆◆◆
AMV6-O2245				◆				◆◆◆◆
AMV6-O2295					◆			◆◆◆◆
AMV6-O2349						◆		◆◆◆◆
AMV6-O2405							◆	◆◆◆◆
AMV6-O2460								◆◆◆◆◆



NOTE!

◆ means a basic module.

2.2.2 Combinations of Indoor and Outdoor Units

(1) The following table indicates the number of IDU for ODU:

ODU model	Max number of connectable IDU (unit)	ODU model	Max number of connectable IDU (unit)
AMV6-O224	13	AMV6-O1400	66
AMV6-O280	16	AMV6-O1455	69
AMV6-O335	19	AMV6-O1510	71
AMV6-O400	23	AMV6-O1565	74
AMV6-O450	26	AMV6-O1630	77
AMV6-O504	29	AMV6-O1680	80
AMV6-O560	33	AMV6-O1734	80
AMV6-O615	36	AMV6-O1790	80
AMV6-O680	39	AMV6-O1845	80
AMV6-O730	43	AMV6-O1905	80
AMV6-O784	46	AMV6-O1959	80
AMV6-O840	50	AMV6-O2015	80
AMV6-O895	53	AMV6-O2070	80
AMV6-O950	56	AMV6-O2125	80
AMV6-O1015	59	AMV6-O2180	80
AMV6-O1065	63	AMV6-O2245	80
AMV6-O1119	64	AMV6-O2295	80
AMV6-O1175	64	AMV6-O2349	80
AMV6-O1230	64	AMV6-O2405	80
AMV6-O1290	64	AMV6-O2460	80
AMV6-O1345	64	—	—

(2) The total capacity of indoor units should be within 50%~135% of that of outdoor units.

(3) When any one of the indoor units receives the operation command, the outdoor unit starts running according to the required capability; when all indoor unit stops running, the outdoor unit stops operation.

2.3 Names of Main Parts

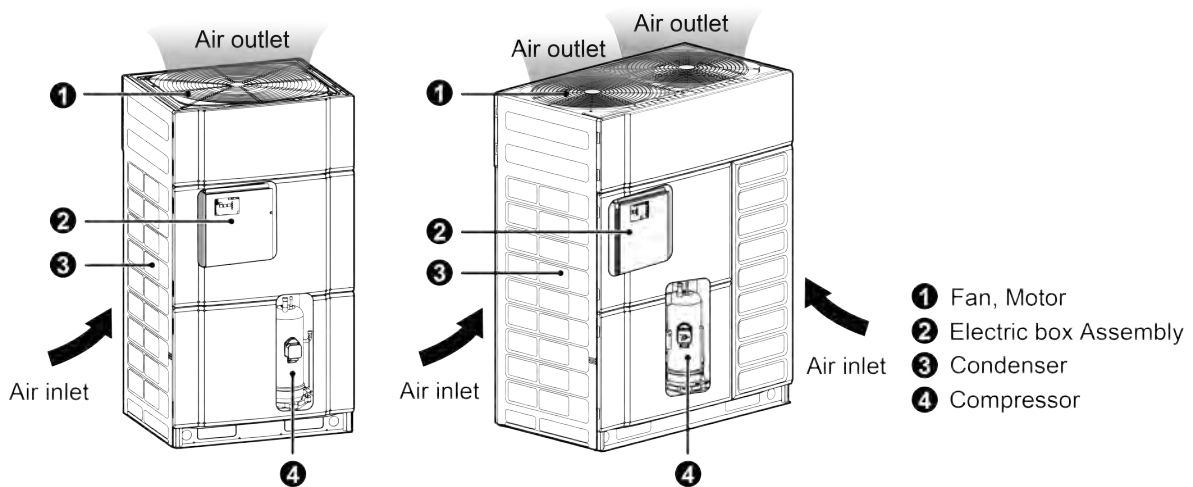

Fig. 2.3.1

2.4 The Range of Production Working Temperature

—	Cooling	Heating
Ambient temperature	-15°C*~55°CDB	-30°C~24°CDB
Indoor temperature	14°C~25°CWB	15°C~27°CDB
Indoor humidity	≤80%	

*Note: Cooling at -15~-5°C is conditional. Please inquire our engineers for more information. Generally, the lowest operating temperature for cooling is -5°C.

When the indoor units are all VRF fresh air processor, the unit operating range is as follows:

Cooling	Ambient temperature: 16°C~45°C
Heating	Ambient temperature: -7°C~16°C





NOTE!

If exceeding the temperature range for working, the product may be damaged, which is not within the warranty range.

2.5 Standard Parts

Please use the following standard parts supplied by ASAMI.

Parts for Outdoor Unit				
Number	Name	Picture	Quantity	Remarks
1	Owner's Manual		1	—
2	Wiring (match with resistance)		1	Must be connected to the last IDU of communication connection
3	L-shape pipe		1	Used for connecting pipes

3 Product Installation

3.1 Safety Precautions for Installing, Repairing and Moving Units

- (1) The unit should not be installed in places with high environmental pH, high voltage fluctuations, vehicles and ships.
- (2) Do not touch the fins of the heat exchanger. Improper touch can cause damage or injury.
- (3) Do not mix any substances except the refrigerant when installing or moving the refrigerant circuit, and do not leave any air in the pipe. If air or other substances are mixed in the refrigerant circuit, the system pressure will rise and it will cause compressor explosion.
- (4) Do not charge the refrigerant other than the specified one when installing or moving the unit. Otherwise, it may cause problems such as poor operation, malfunction, mechanical fault, etc., and even cause major safety accident.
- (5) When moving or repairing the unit, be sure to use the pressure gauge. First, perform the cooling operation, and then completely close the high pressure side valve (liquid valve). When the pressure gauge reads 0~0.05MPa, completely close the low pressure side valve (air valve), and then immediately stop operation and cut off the power.
- (6) When recovering the refrigerant, it is necessary to ensure that the connection pipe can be disassembled only after the liquid valve and the air valve are completely closed and the

power is turned off. If disassembling the connection pipe when the power hasn't been cut off and the compressor still running, the air will be mixed into the system and then the pressure will rise, which will cause compressor explosion.

- (7) When installing the unit, make sure that the connection pipe is securely connected before turning on the compressor. If the compressor is turned on before the connection of the connection pipe is completed and the shut-off valve is opened, the air will be mixed into the system and then the pressure will rise, which will cause compressor explosion.
- (8) Wiring between indoor unit and outdoor unit must be properly connected by adopting the specified electric wires and the terminals should be fixed well and not affected by external forces. Poor connection or fixing may cause a fire accident.
- (9) No connection is allowed in the middle of the wire. When the length of the connection wire is not enough, please contact the designated service store to re-equip a dedicated electric wire with sufficient length.

3.2 Outdoor Unit Installation

3.2.1 Product Size Drawing

The product photos are only for reference. Please refer to the actual product.

Outline and Physical Dimension of AMV6-O224,AMV6-O280,AMV6-O335

Unit: mm

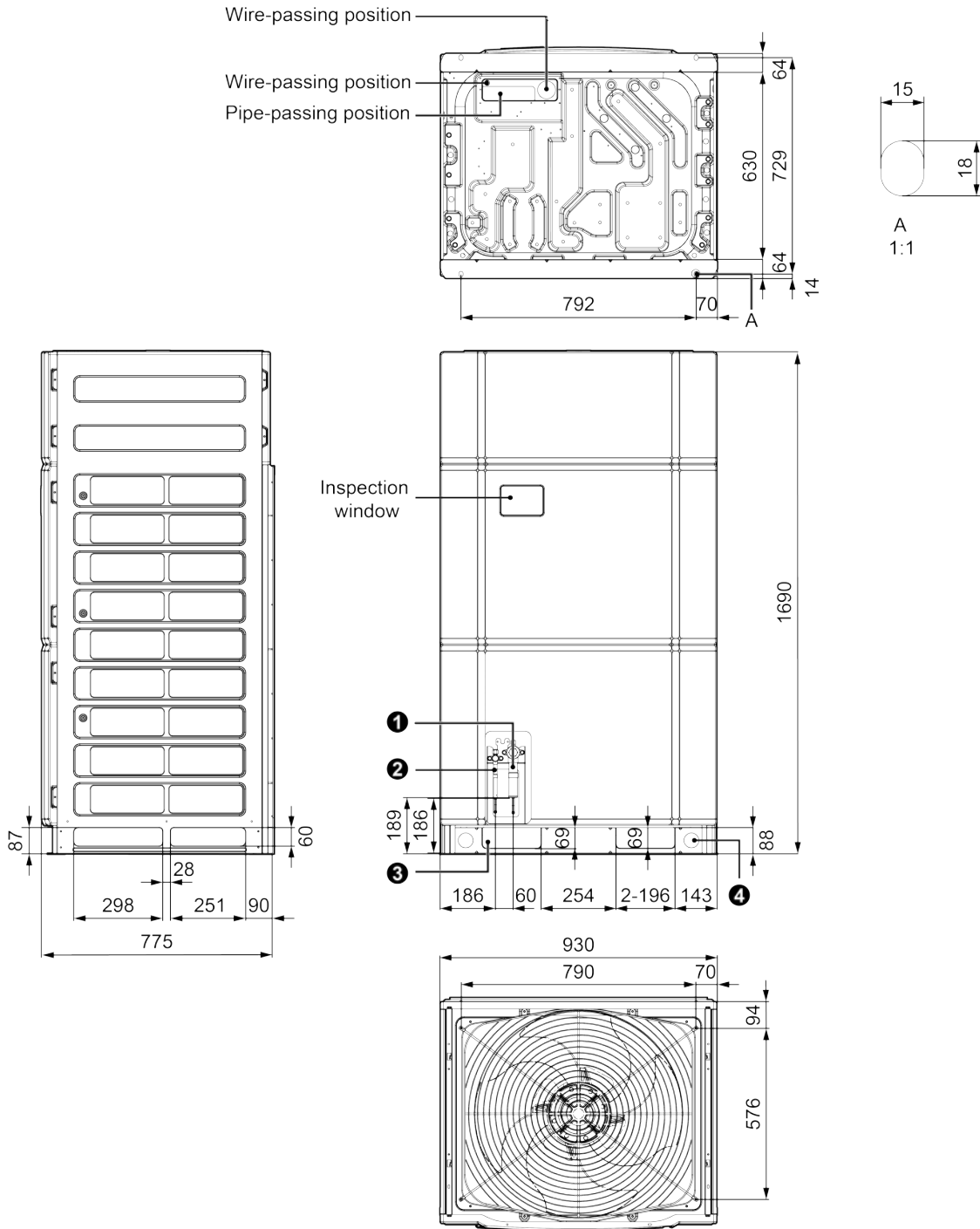

Fig. 3.2.1

No.	Name	Pipe diameter		
		AMV6-O224	AMV6-O280	AMV6-O335
①	Gas pipe	Φ19.05	Φ22.2	Φ25.4
②	Liquid pipe	Φ9.52	Φ9.52	Φ12.7
③	Pipe and wiring passing hole (L×W)	196×69	196×69	196×69
④	Hoist hole	Φ50	Φ50	Φ50

Outline and Physical Dimension of AMV6-O400,AMV6-O450,AMV6-O504,
AMV6-O560, AMV6-O615 unit.

Unit: mm

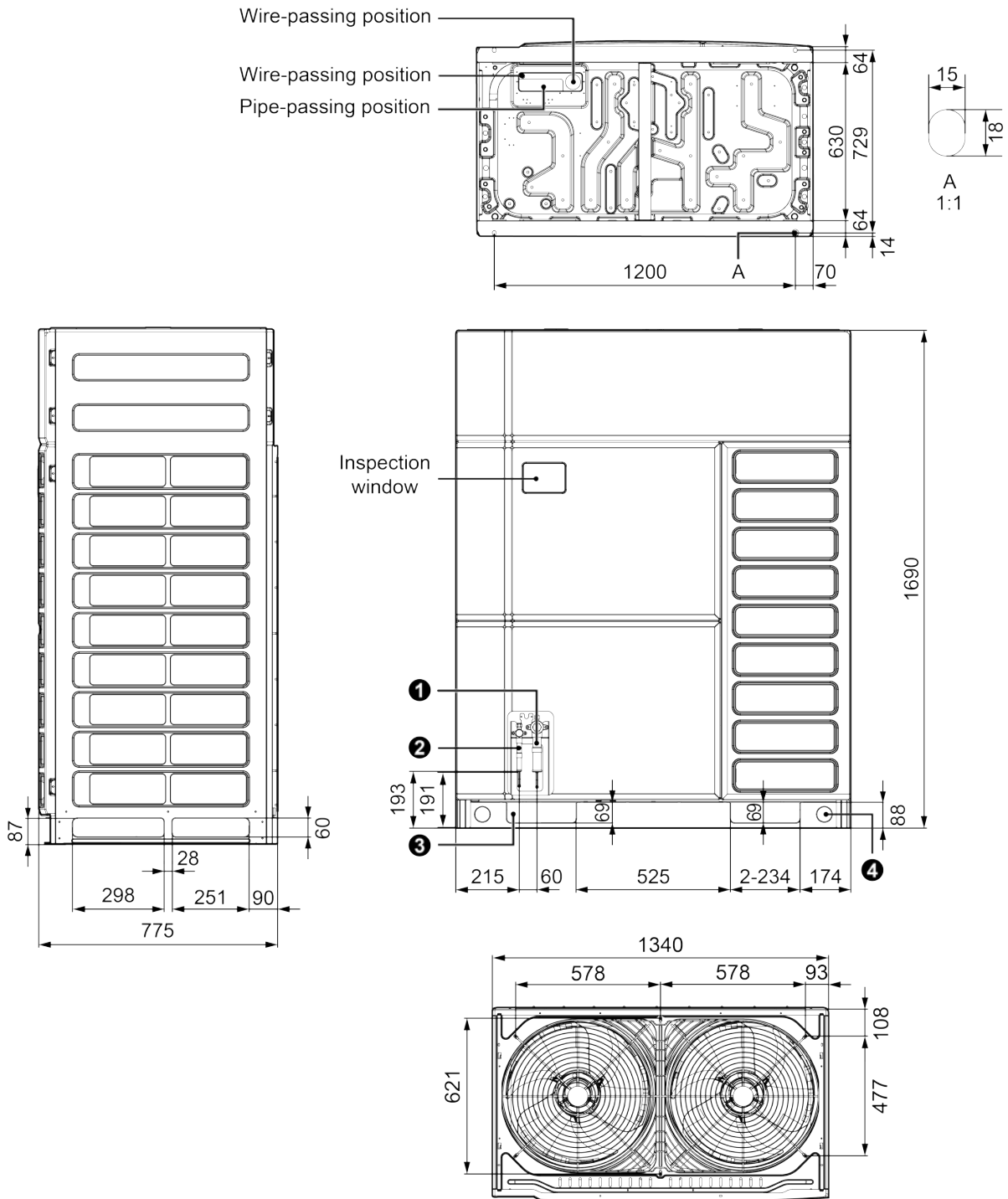

Fig. 3.2.2

DC Inverter Multi VRF System

No.	Name	Pipe diameter	
		AMV6-O400	AMV6-O450
①	Gas pipe	Φ25.4	Φ28.6
②	Liquid pipe	Φ12.7	Φ12.7
③	Pipe and wiring passing hole (L×W)	234×69	234×69
④	Hoist hole	Φ50	Φ50

No.	Name	Pipe diameter		
		AMV6-O504	AMV6-O560	AMV6-O615
①	Gas pipe	Φ28.6	Φ28.6	Φ28.6
②	Liquid pipe	Φ15.9	Φ15.9	Φ15.9
③	Pipe and wiring passing hole (L×W)	234×69	234×69	234×69
④	Hoist hole	Φ50	Φ50	Φ50

3.2.2 Select Installation Position

Conditions for selecting the installation position:

- (1) Install the unit at a place where is adequate to withstand the weight of the unit and make sure the unit would not shake or fall off.
- (2) Fully consider the influence of strong winds, typhoons and earthquakes when selecting the installation site, and strengthen the installation.
- (3) The influence of flammable, explosive, corrosive gases or exhaust gases should be avoided.
- (4) Ensure that there is a certain space for heat exchanging and maintenance, so that the ventilation is smooth and the running is reliable.
- (5) Outdoor units and indoor units should be as close as possible to minimize the length and angle of the cooling pipes.
- (6) Do not allow children to approach the unit. Preventive measures should be taken to prevent children from contacting the unit.
- (7) The unit should not be installed in places with high environmental pH or high voltage fluctuations, and places such as vehicles and ships.
- (8) Do not install the unit at the place where is close to the equipment that generates electromagnetic waves. Electromagnetic waves can affect the control system and cause fault.

3.2.2.1 Take Seasonal Wind into Consideration When Installing the Outdoor Unit

(1) Anti-monsoon installation requirements for unit not connecting exhaust duct.

When the exhaust duct is not connected, a protective cover should be installed according to the seasonal wind circumstances.



NOTE!

The photo is only for reference. Please refer to the installation locale.

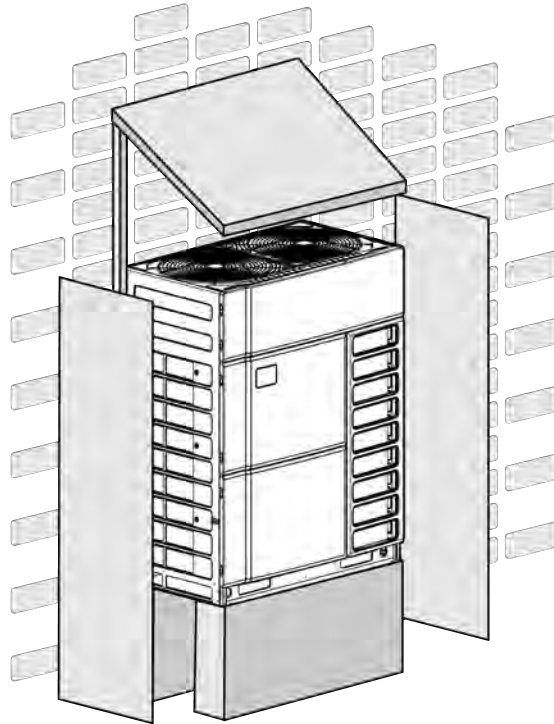

Fig. 3.2.3

(2) Anti-monsoon installation requirements for unit connecting exhaust duct:

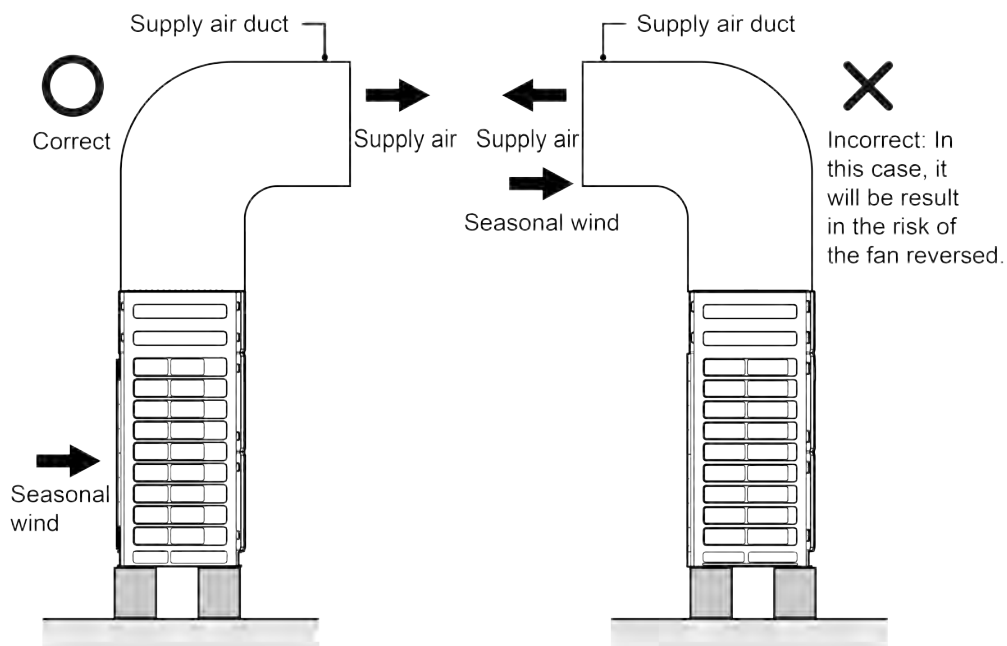

Fig. 3.2.4

3.2.2.2 Take Snow into Consideration When Installing the Outdoor Unit

When the unit is installed, the snow should be taken into consideration for the height of the base.



NOTE!

The photo is only for reference. Please refer to the installation locale.

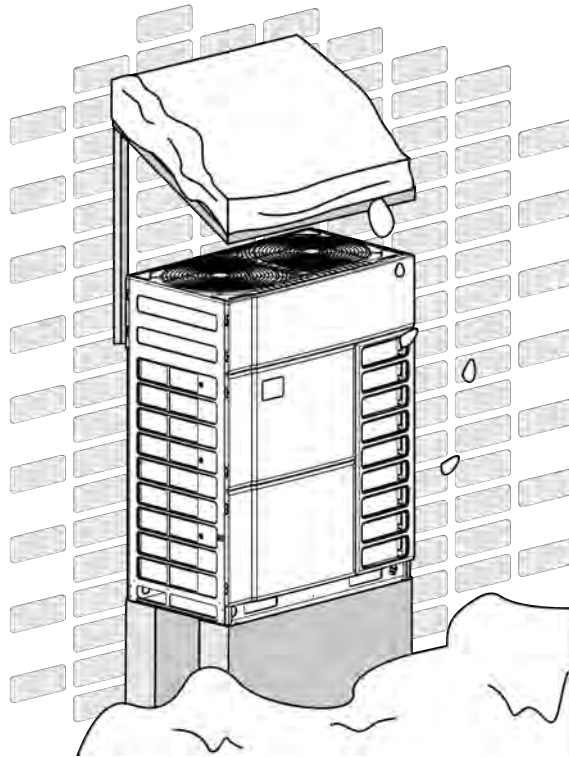

Fig. 3.2.5

3.2.3 Installation Space Requirements

The installation space of the unit should consider the maintenance space of the unit and the ventilation of the unit. Select an installation method according to the actual situation.

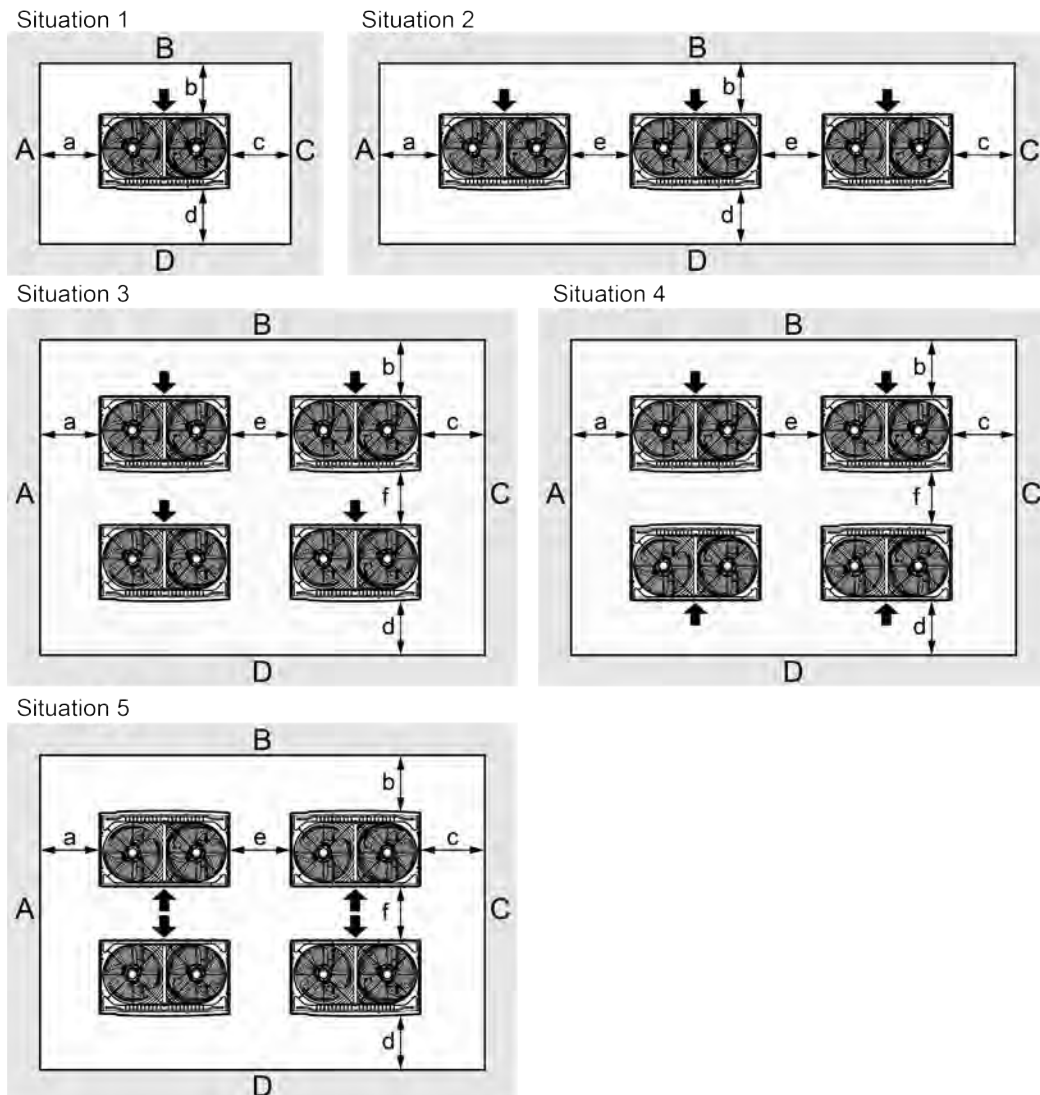

Fig.3.2.6

Unit: mm

Status	A+B+C+D	A+B
Status 1	$a \geq 300$ $b \geq 100$ $c \geq 100$ $d \geq 500$	$a \geq 300$ $b \geq 300$
Status 2	$a \geq 300$ $b \geq 100$ $c \geq 100$ $d \geq 500$ $e \geq 100$	$a \geq 300$ $b \geq 300$ $e \geq 400$
Status 3	$a \geq 300$ $b \geq 100$ $c \geq 100$ $d \geq 500$ $e \geq 200$ $f \geq 600$	—

Status	A+B+C+D	A+B
Status 4	$a \geq 300$ $b \geq 100$ $c \geq 100$ $d \geq 100$ $e \geq 200$ $f \geq 500$	—
Status 5	$a \geq 300$ $b \geq 500$ $c \geq 100$ $d \geq 500$ $e \geq 200$ $f \geq 900$	—



NOTE!

- (1) The installation space shown above is based on the cooling operation when the outdoor temperature is 35°C. If the outdoor temperature exceeds 35°C or the heat load is large, and all outdoor units are operating at an excess capacity, the space at the suction side should be increased.
- (2) When disassembling or installing the unit, the operation may be affected by obstacles, and the distance from the unit to the wall surface may be appropriately increased.
- (3) When two or more units are installed and placed, the operation may be affected by the adjacent units. The distance between the two adjacent units is “e” ≥ 100mm.

Unit: mm

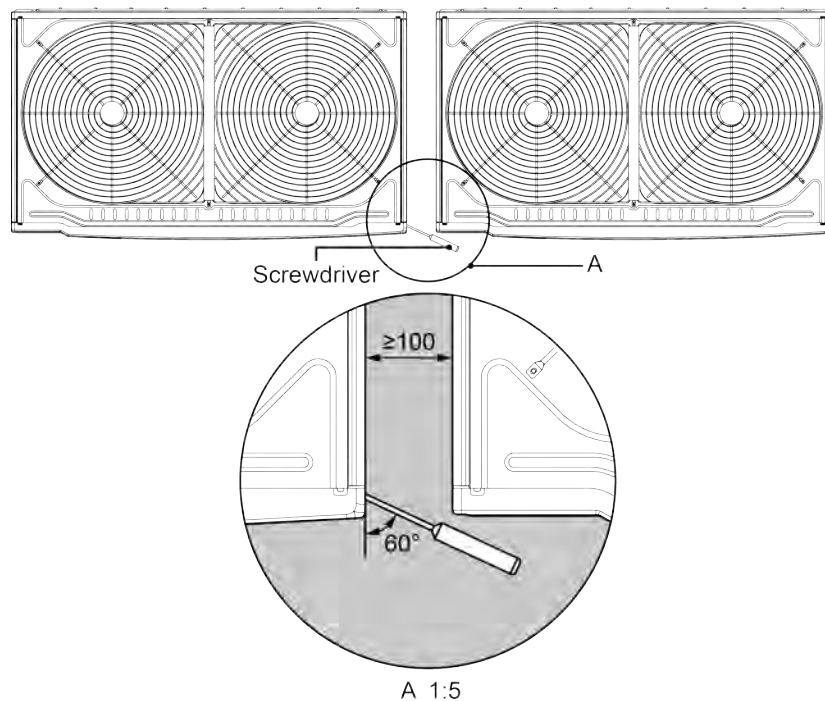

Fig. 3.2.7

- (4) When the unit is installed in place around by walls, the height of left and right side walls is not limited; the height of air inlet side wall is below 500mm, and the height of front side wall

is below 1500mm. The unit is installed in a space with only two walls, A and B, and the height of the B wall is not limited.

- (5) If the wall exceeds the above value, increase the space as follows.

Unit: mm

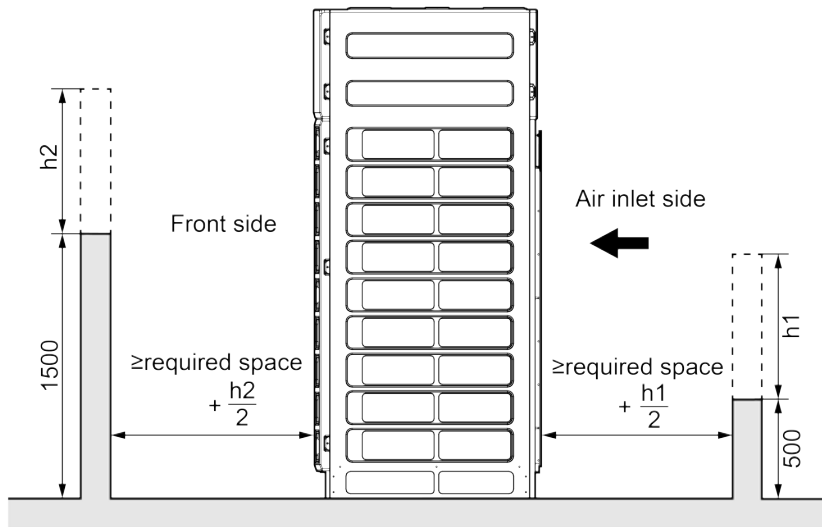

Fig. 3.2.8

- (6) If there is an obstacle above the unit, install the unit as follows.

In principle, the top of the unit is required to be more than 3000 mm from the top wall. If the space around the front, back, left and right sides of the unit is open space, the top of the unit is required to be 1500mm or more from the top wall, as shown in the fig. as below. If the size is less than 1500mm, or if the space around the unit is not open, you need to connect an exhaust duct for smooth ventilation, as shown below.

Unit: mm

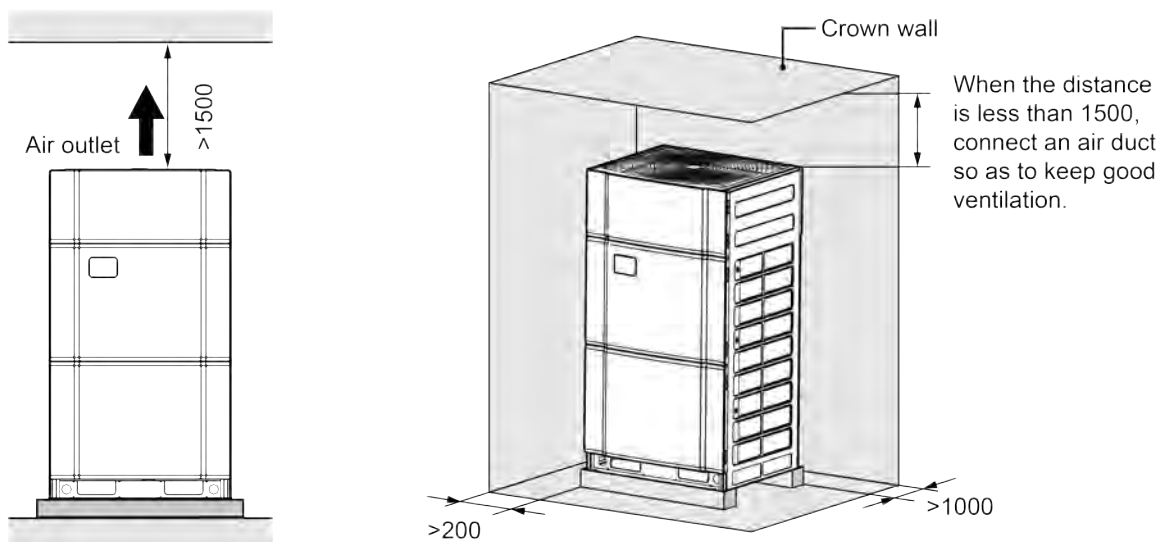

Fig. 3.2.9

3.2.4 Installation Space Requirements for Equipment Floor

When the outdoor unit is installed in the equipment floor, it needs to connect an air exhaust duct.

The opening ratio of the shutters in the equipment floor is not less than 60%, and the horizontal angle of louvers is less than 20°.

3.2.5 Diagram of installation foundation

The concrete foundation of the ODU must be strong enough. Ensure that the drainage is smooth and that the ground drainage or floor drainage is not affected.

Requirements on the concrete foundation are as follows:

- (1) The concrete foundation must be flat and have enough rigidity and strength to undertake the unit's weight during running. The height of the foundation is 200 mm to 300 mm, which is determined based on the size of the unit. If it is installed in place with large snowfall, increase the height of the foundation so that the air inlet side is not buried by snow.
- (2) Build a drainage ditch around the foundation to discharge the condensate water.
- (3) If the air conditioner is installed on the roof, check the intensity of the building and take waterproof measures.
- (4) If a u-steel foundation is adopted, the structure must be designed with sufficient rigidity and strength.
- (5) Cement foundation diagram is shown as follows:

Unit: mm

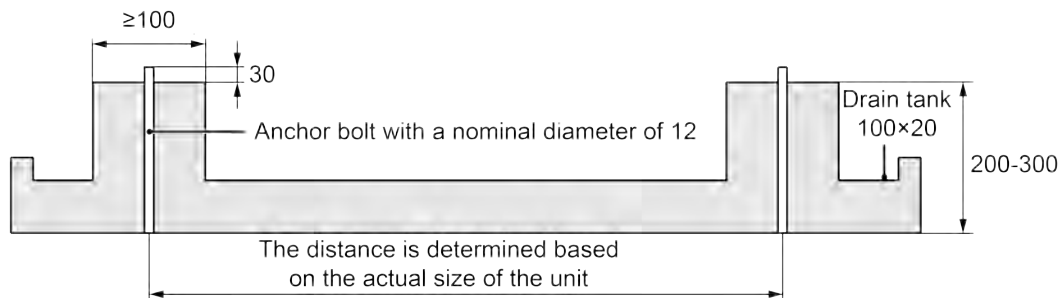

Fig. 3.2.10

3.2.6 Shock absorption requirements

The outdoor unit should be firmly fixed. Thick rubber sheets or corrugated rubber damping rubber mats with a thickness of 20mm at least and a width of 100mm at least should be placed between the unit and the foundation. The installation requirements are shown as follows.

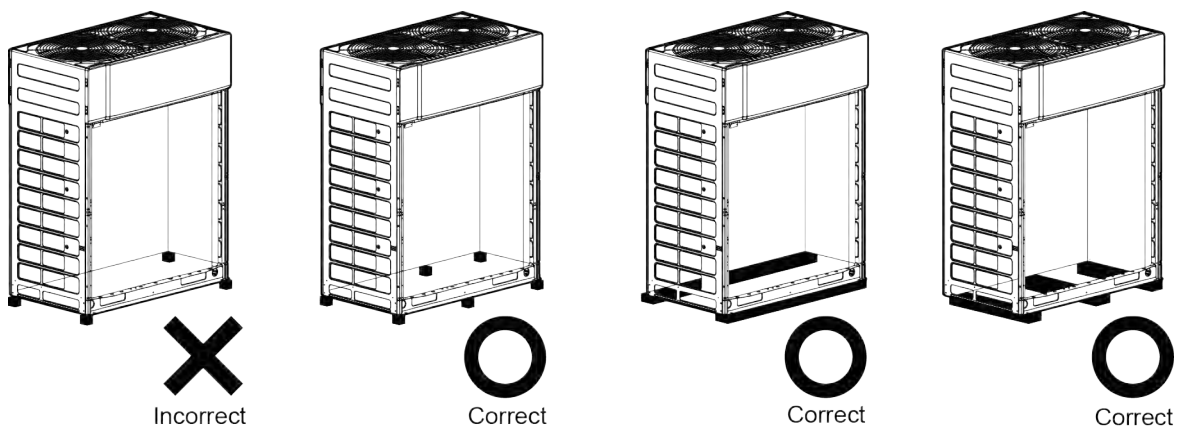

Fig. 3.2.11

3.3 Pipeline Design

3.3.1 Notices for Pipeline Design

- (1) Air-conditioning installation should not damage the load-bearing structure and decorative style of the building.
- (2) Air-conditioning pipes should be laid along the bottom of the beam. If the pipes meet at the same elevation, they should be treated as follows:
 - 1) Drain pipes, ducts and pressure pipes avoid gravity pipes.
 - 2) Ducts and small tubes give priority to big tubes.
- (3) It should be ensured that the direction is correct, the branch is reasonable, the length is the shortest, and the brazed joint and bend are minimized.
- (4) The refrigerant pipe must bypass the inspection port of the unit, leaving sufficient maintenance space.
- (5) The vertical pipe should be laid in the air conditioning pipe well. The horizontal pipe should be laid in the ceiling.

3.3.2 Pipeline Requirement

Pipe specification is shown as follows:

R410A Refrigerant System		
External diameter(mm)	Thickness(mm)	Type
Φ6.35	≥0.8	O
Φ9.52	≥0.8	O
Φ12.70	≥0.8	O
Φ15.9	≥1.0	O
Φ19.05	≥1.0	1/2H
Φ22.2	≥1.2	1/2H
Φ25.40	≥1.2	1/2H
Φ28.60	≥1.2	1/2H
Φ31.80	≥1.3	1/2H
Φ34.90	≥1.3	1/2H
Φ38.10	≥1.5	1/2H
Φ41.30	≥1.5	1/2H
Φ44.5	≥1.5	1/2H
Φ51.4	≥1.5	1/2H
Φ54.1	≥1.5	1/2H

Remarks:

- ① The inner and outer surfaces of the pipeline shall be free of pinholes, cracks, skinning, foaming, inclusions, copper powder, carbon deposits, green rust, dirt and severe oxide film, and shall not allow obvious scratches, pits and spots. defect.
- ② Once the inside of the copper tube is cleaned and dried, the nozzle must be tightly sealed with a cap, plug or tape.

3.3.3 Allowable pipe length and height difference among indoor and outdoor units

Y type branch joint is adopted to connect indoor and outdoor units. Connecting method is shown in the figure below.

Unit:m

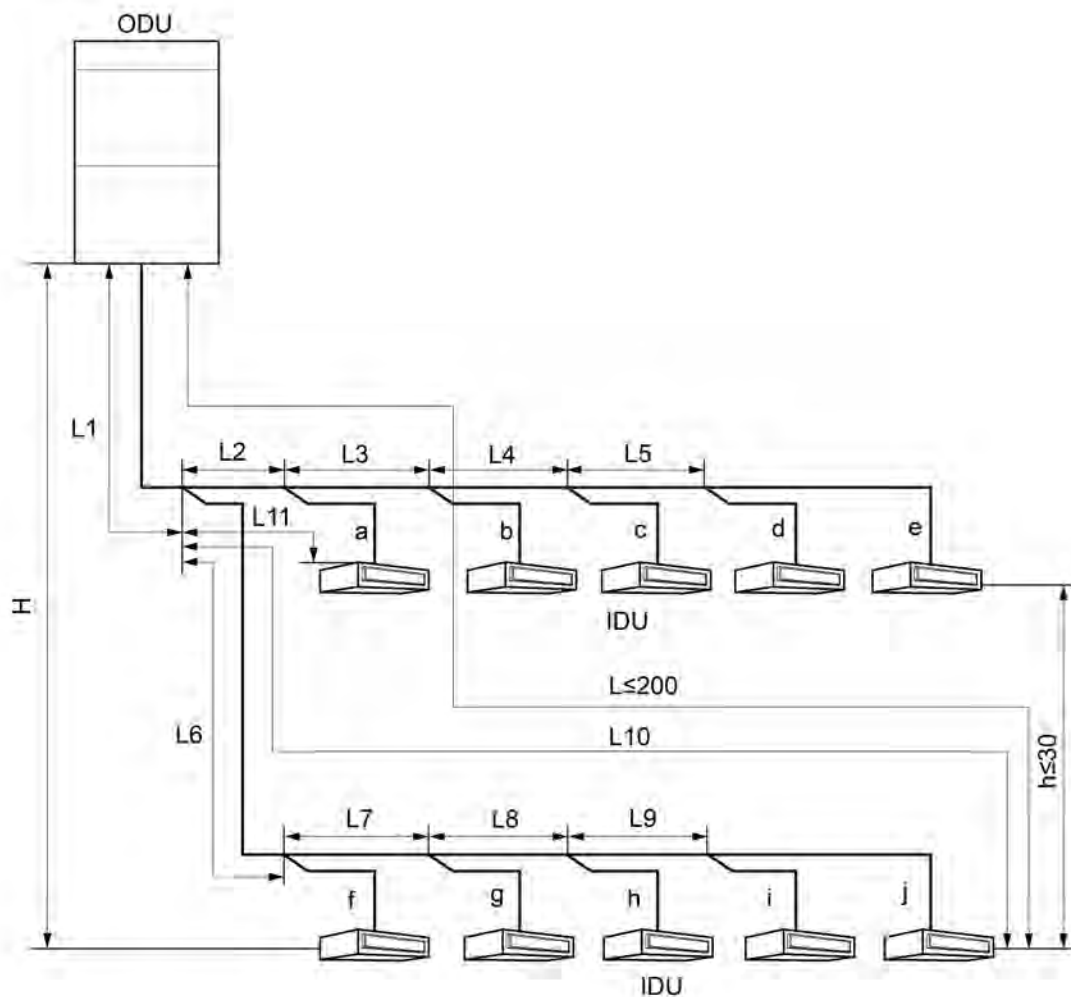

Fig. 3.3.1

L10: Length from the first branch to the farthest IDU;

L11: Length from the first branch to the nearest IDU;

Equivalent length of branch of IDU is 0.5m.

—		Length(m)	Fitting Pipe
Total length (actual length) of fitting pipe		≤1000	$L1+L2+L3+L4+\dots+L9+a+b+\dots+i+j$
Length of farthest fitting pipe(m)	Actual length	≤200	$L1+L6+L7+L8+L9+j$
	Equivalent length	≤240	
Equivalent length from the first branch to the furthest indoor unit ^{*1}		≤120	$L6+L7+L8+L9+j$
Height difference between outdoor unit and indoor unit H ^{*2}	Outdoor unit at upper	≤100	—
	Outdoor unit at lower	≤110	—
Height difference between indoor units		≤30	—

**NOTES!**

- (1) Note 1: Normally, the pipe length from the first branch of IDU to the farthest IDU is 40m. When those three conditions as below are satisfied, the length can reached 120m.
- 1) Actual length of pipe in total: $L1+L2 \times 2+L3 \times 2+L4 \times 2+\dots+L9 \times 2+a+b+\dots+i+j \leq 1000\text{m}$;
 - 2) Length between each IDU and its nearest branch a, b, c, d, e, f, g, h, i, $j \leq 40\text{m}$;
 - 3) Difference between the pipe length from the first branch of IDU to the farthest IDU and the pipe length from the first branch of IDU to the nearest IDU: $L10-L11 \leq 40\text{m}$.
- (2) Note 2: When the ODU is at the up side and the height drop exceeds 50m, please contact the engineer; when the ODU is at the lower side and the height drop exceeds 90m, please contact the engineer.
- When the ODU is at the up side and the height drop between the IDU and ODU is more than 50m, the liquid pipe size from the ODU to the first manifold of IDU must be enlarged.
- When the ODU is at the lower side and the height drop between the IDU and ODU is more than 40m, the liquid pipe size from the ODU to the first manifold of IDU must be enlarged.
- (3) When the height drop among IDUs is more than 15m, the liquid pipe size from the ODU to the first manifold of IDU must be increased.
- (4) When the maximum length of the main pipe from ODU to the first branch of IDU is $\geq 90\text{m}$, then adjust the pipe size of the gas pipe and liquid pipe of main pipe according to the following table.

Outdoor Model	Gas pipe size(mm)	Liquid pipe size(mm)
AMV6-O224	No need to enlarge pipe size	No need to enlarge pipe size
AMV6-O280	No need to enlarge pipe size	Φ12.7
AMV6-O335	Φ28.6	Φ15.9
AMV6-O400	Φ28.6	Φ15.9
AMV6-O450	Φ31.8	Φ15.9
AMV6-O504	Φ31.8	Φ19.05
AMV6-O560	Φ31.8	Φ19.05
AMV6-O615	Φ31.8	Φ19.05
AMV6-O680	Φ31.8	Φ19.05
AMV6-O730	Φ38.1	Φ22.2
AMV6-O784	Φ38.1	Φ22.2
AMV6-O840	Φ38.1	Φ22.2
AMV6-O895	Φ38.1	Φ22.2
AMV6-O950	Φ38.1	Φ22.2
AMV6-O1015	Φ41.3	Φ22.2
AMV6-O1065	Φ41.3	Φ22.2
AMV6-O1119	Φ41.3	Φ22.2
AMV6-O1175	Φ41.3	Φ22.2
AMV6-O1230	Φ41.3	Φ22.2
AMV6-O1290	Φ41.3	Φ22.2
AMV6-O1345	Φ41.3	Φ22.2
AMV6-O1400	Φ41.3	Φ22.2
AMV6-O1455	Φ44.5	Φ22.2
AMV6-O1510	Φ44.5	Φ22.2

Outdoor Model	Gas pipe size(mm)	Liquid pipe size(mm)
AMV6-O1565	Φ44.5	Φ22.2
AMV6-O1630	Φ44.5	Φ22.2
AMV6-O1680	Φ44.5	Φ22.2
AMV6-O1734	Φ44.5	Φ22.2
AMV6-O1790	Φ44.5	Φ22.2
AMV6-O1845	Φ44.5	Φ22.2
AMV6-O1905	Φ44.5	Φ22.2
AMV6-O1959	Φ44.5	Φ22.2
AMV6-O2015	Φ51.4	Φ25.4
AMV6-O2070	Φ51.4	Φ25.4
AMV6-O2125	Φ51.4	Φ25.4
AMV6-O2180	Φ51.4	Φ25.4
AMV6-O2245	Φ51.4	Φ25.4
AMV6-O2295	Φ51.4	Φ25.4
AMV6-O2349	Φ51.4	Φ25.4
AMV6-O2405	Φ51.4	Φ25.4
AMV6-O2460	Φ51.4	Φ25.4

- (5) If the liquid pipe is enlarged for a situation from (2) ~ (4), please do not enlarged any more.
- (6) If the length between an IDU and its nearest branch is above 15m, then increase the size of the liquid pipe (only for the pipe size that is ≤6.35mm) and gas pipe (only for the pipe size that is ≤9.52mm) of IDU.

3.3.4 Connection Pipe among Outdoor Modules

- (1) The pipe among the outdoor modules must be at the same level or tilted upwards. Otherwise, the refrigeration oil will remain in the pipe.

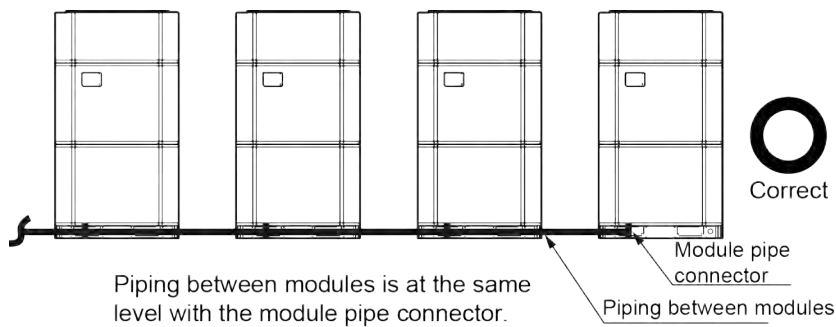

Fig. 3.3.2

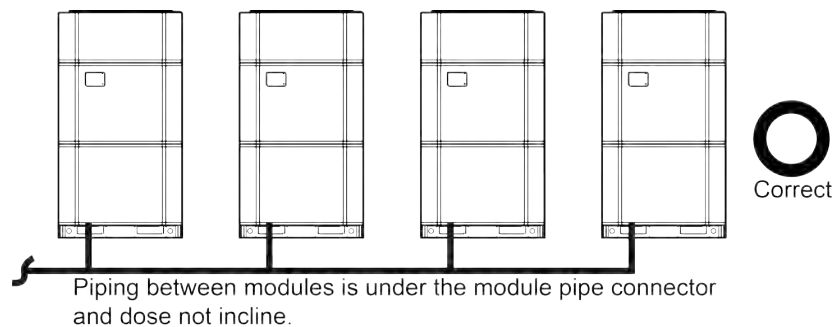

Fig. 3.3.3

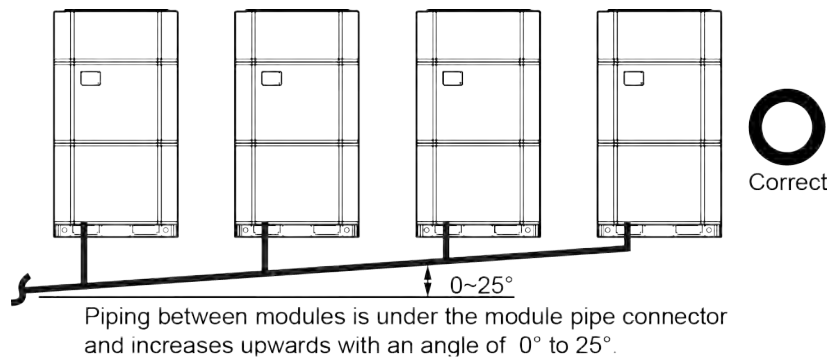

Fig. 3.3.4

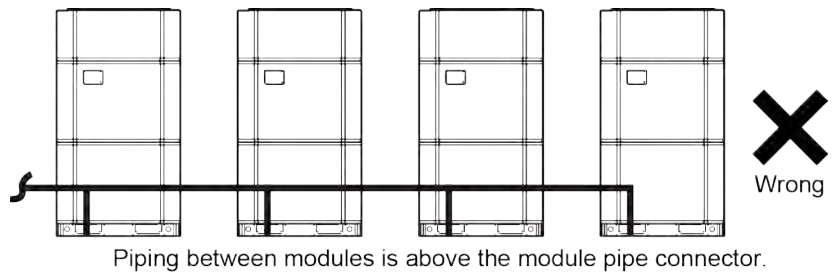

Fig. 3.3.5

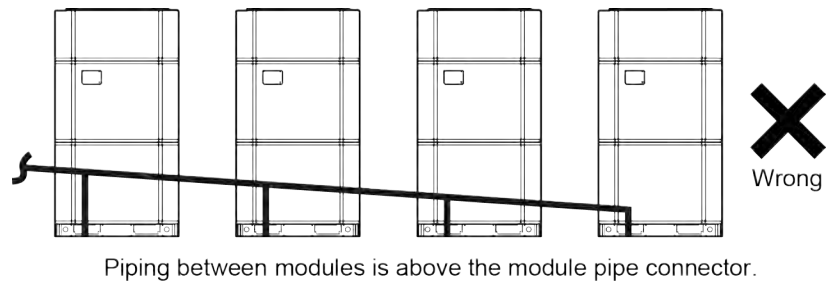

Fig. 3.3.6

(2) The drop and the length of the pipe between the outdoor units are as follows.

Unit:m

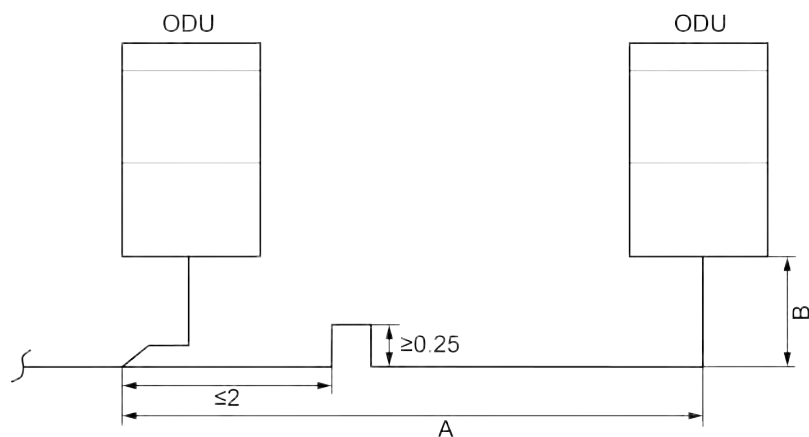

Fig. 3.3.7

NOTE!

When the distance $A+B$ between the outdoor modules exceeds 2m, U-type oil trap should be added at low-pressure gas pipe and is no more than 2m away from the outdoor manifold, and $A+B \leq 10m$. The height drop among the outdoor units is 0m.

3.3.5 Pipe Selection

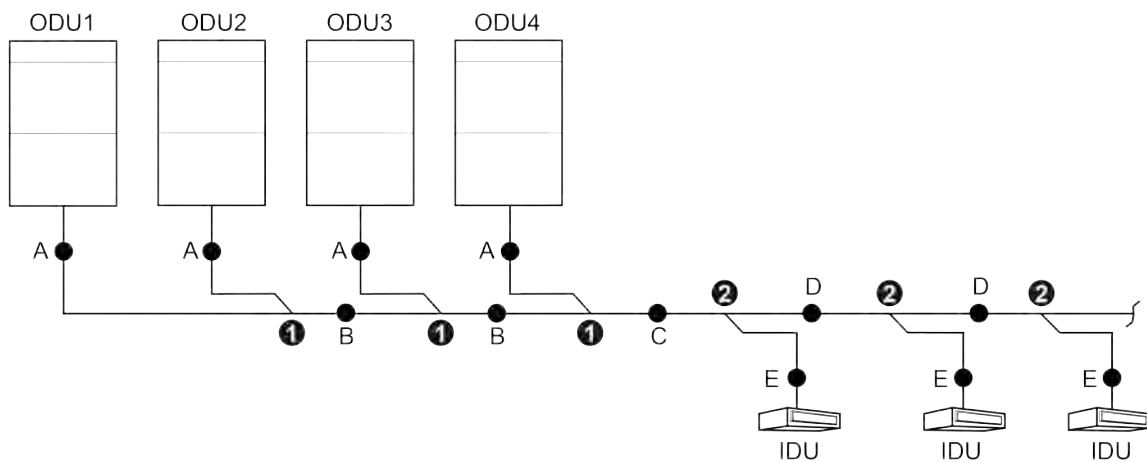

Fig. 3.3.8

(1) When it's modular units connection, the ODU must be installed in capacity order: $ODU\ 4 \geq ODU\ 3 \geq ODU\ 2 \geq ODU\ 1$.

(2) Pipe "A" between the outdoor unit and the manifold of outdoor unit.

The pipe size is based on the capacity of upstream module.

Basic module	Pipe between ODU and the first branch of IDU	
	Gas pipe(mm)	Liquid pipe(mm)
AMV6-O224	Φ19.05	Φ9.52
AMV6-O280	Φ22.2	Φ9.52
AMV6-O335	Φ25.4	Φ12.7
AMV6-O400	Φ25.4	Φ12.7
AMV6-O450	Φ28.6	Φ12.7
AMV6-O504	Φ28.6	Φ15.9
AMV6-O560	Φ28.6	Φ15.9
AMV6-O615	Φ28.6	Φ15.9

(3) Fitting pipe "B" between outdoor unit manifold; fitting pipe "C" from outdoor unit to indoor manifold.

Pipe size (between two manifolds from basic modules) is based on the total capacity of upstream modules.

Total capacity of upstream module Q(kW)	Pipe size between manifolds	
	Gas pipe(mm)	Liquid pipe(mm)
$Q \leq 25.2$	Φ19.05	Φ9.52
$25.2 < Q \leq 30.0$	Φ22.2	Φ9.52
$30.0 < Q \leq 40.0$	Φ25.4	Φ12.7
$40.0 < Q \leq 45.0$	Φ28.6	Φ12.7
$45.0 < Q \leq 68.0$	Φ28.6	Φ15.9
$68.0 < Q \leq 96.0$	Φ31.8	Φ19.05
$96.0 < Q \leq 135.0$	Φ38.1	Φ19.05
$135.0 < Q \leq 186.0$	Φ41.3	Φ19.05
$186.0 < Q$	Φ44.5	Φ22.2

(4) Fitting pipe "D" between indoor side manifolds.

Pipe size (between two manifolds at indoor unit side) is based on the total capacity of downstream indoor unit(s).

Total capacity of downstream indoor unit(s) C(kW)	Dimension of the pipe of indoor branch	
	Gas pipe(mm)	Liquid pipe(mm)
$C \leq 5.0$	$\Phi 12.7$	$\Phi 6.35$
$5.0 < C \leq 14.2$	$\Phi 15.9$	$\Phi 9.52$
$14.2 < C \leq 25.2$	$\Phi 19.05$	$\Phi 9.52$
$25.2 < C \leq 30.0$	$\Phi 22.2$	$\Phi 9.52$
$30.0 < C \leq 40.0$	$\Phi 25.4$	$\Phi 12.7$
$40.0 < C \leq 45.0$	$\Phi 28.6$	$\Phi 12.7$
$45.0 < C \leq 68.0$	$\Phi 28.6$	$\Phi 15.9$
$68.0 < C \leq 96.0$	$\Phi 31.8$	$\Phi 19.05$
$96.0 < C \leq 135.0$	$\Phi 38.1$	$\Phi 19.05$
$135.0 < C \leq 186.0$	$\Phi 41.3$	$\Phi 19.05$
$186.0 < C$	$\Phi 44.5$	$\Phi 22.2$

(5) Fitting pipe "E" between indoor unit and manifold.

Manifold should be matched with fitting pipe of indoor unit.

Rated capacity of indoor unit C(kW)	Pipe between indoor branch and IDU	
	Gas pipe(mm)	Liquid pipe(mm)
$C \leq 2.8$	$\Phi 9.52$	$\Phi 6.35$
$2.8 < C \leq 5.0$	$\Phi 12.7$	$\Phi 6.35$
$5.0 < C \leq 14.2$	$\Phi 15.9$	$\Phi 9.52$
$14.2 < C \leq 25.2$	$\Phi 19.05$	$\Phi 9.52$
$25.2 < C \leq 30.0$	$\Phi 22.2$	$\Phi 9.52$
$30.0 < C \leq 40.0$	$\Phi 25.4$	$\Phi 12.7$
$40.0 < C \leq 45.0$	$\Phi 28.6$	$\Phi 12.7$

(6) Select the branch "①" of outdoor module.

—	Model
Select the branch of outdoor module	ML01/A

(7) Select the manifold "②" at indoor side.

Manifold at indoor unit side can be selected as per total capacity of downstream indoor unit(s).

Refer to the following table.

R410A Refrigerant System	Total capacity of downstream indoor unit(s) C(kW)	Model
Y-type Manifold	$C < 20.0$	FQ01A/A
	$20.0 \leq C \leq 30.0$	FQ01B/A
	$30.0 < C \leq 70.0$	FQ02/A
	$70.0 < C \leq 135.0$	FQ03/A
	$135.0 < C$	FQ04/A
T-type Manifold	$C \leq 40.0$	FQ14/H1
	$C \leq 68.0$	FQ18/H1
	$68.0 < C$	FQ18/H2

3.4 Pipeline Installation and Insulation

3.4.1 Pipeline Installation of Refrigeration System

- (1) Before welding the pipeline sealing cap, please make sure there's no refrigerant in pipeline. If welding it directly, it may cause unnecessary property damage or personal injury.
- (2) Conform to the following principles during pipe connection: Connection pipeline should be as short as possible. The height difference between indoor and outdoor units should be as short as possible. Keep number of bends as little as possible. The radius of curvature should be as large as possible.
- (3) Weld the connection pipes between indoor and outdoor unit. Please strictly conform to the requirements for welding process. Rosin joints and pin holes are not allowable.
- (4) When laying the pipes, be careful not to deform them. The radius of bending parts should be more than 200mm. The pipes can't be repeatedly bent or stretched, otherwise the material will get harden. Do not bend or stretch the pipe over three times at the same position.
- (5) Please use a torque wrench to connect union nut on the indoor unit. See the Fig. 3.4.1 as below.

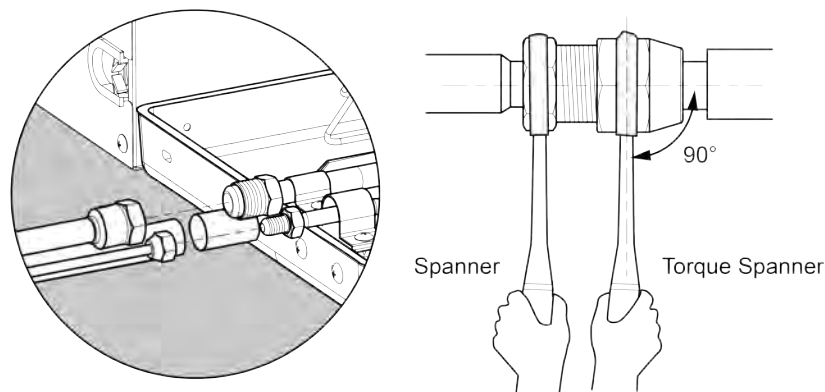

Fig. 3.4.1

- 1) Align the expansion end of copper pipe with the center of threaded joint. Tighten the flare nuts with your hands.
- 2) Tighten the flare nuts with torque wrench until you hear "click" sound.
- 3) Use sponge to wrap the connecting pipe and joints without thermal insulation and tie it up with plastic tape.
- 4) A mounting support for the connection pipe is required.
- 5) The curvature degree of connection pipe should not be small, otherwise the pipe might crack. Installation personnel should use tube bender when bending the pipe.
- 6) Don't forcibly stretch the pipe joint, otherwise indoor capillary or other pipes might be damaged and lead to refrigerant leakage.

3.4.2 Installation of the manifold

The main function of manifold is used to shunt the refrigerant. Pay attention to the following points when installing it:

- (1) When installing the manifold, it should be as close as possible to the indoor unit to reduce the influence of the indoor unit manifold on the refrigerant distribution.

- (2) The manifold must be matched with the equipment. The other products which are not specified by the manufacturer shall not be used.
 - (3) Check the model before installing the manifold. Do not use it incorrectly.
- 1) Y-type manifold and T- type manifold are as follows. Y-type manifold can be installed vertically or horizontally, T-type manifold must be installed horizontally.

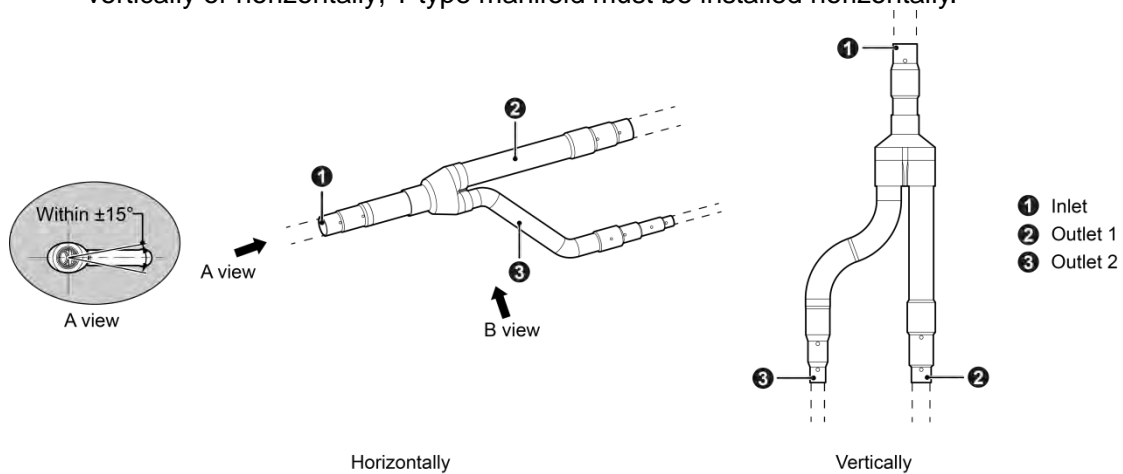

Fig.3.4.2

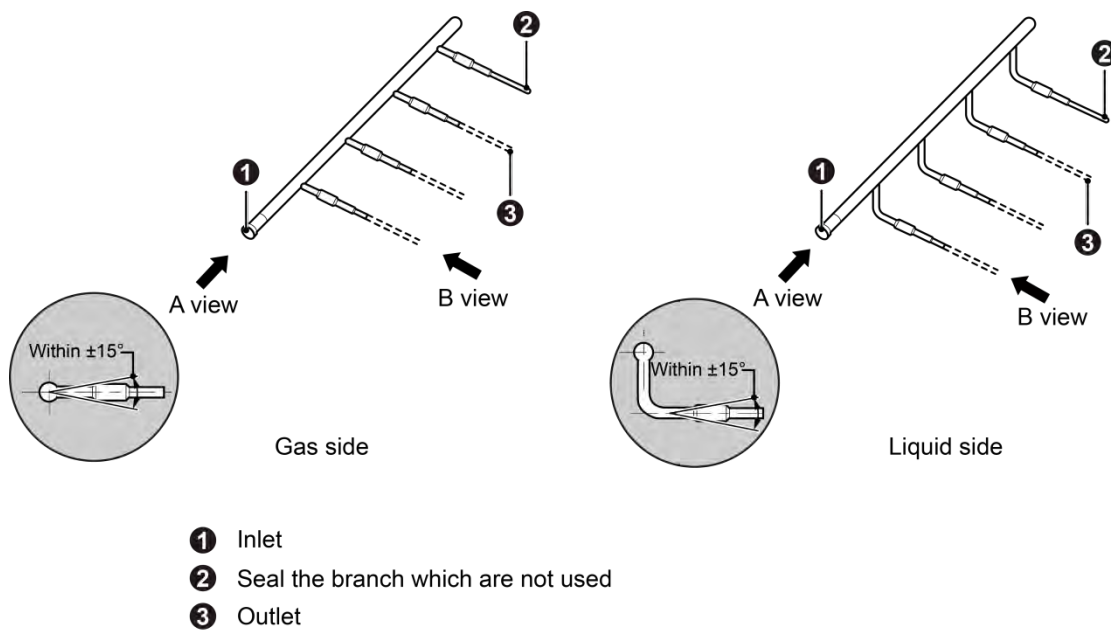

Fig.3.4.3

- 2) The installation of the branch pipe has the following requirements. Please install it according to the angle shown in the figure below. Improper installation may lead to malfunction of the outdoor unit.

Y-type manifold:

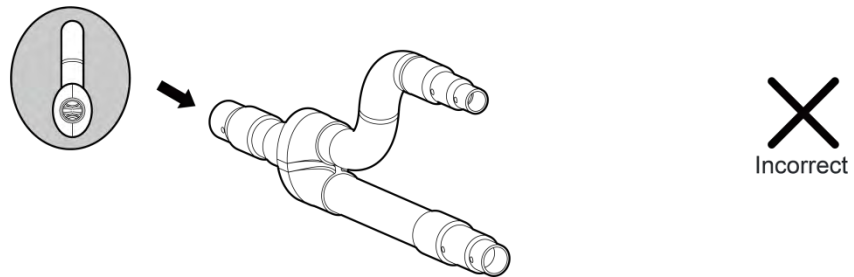
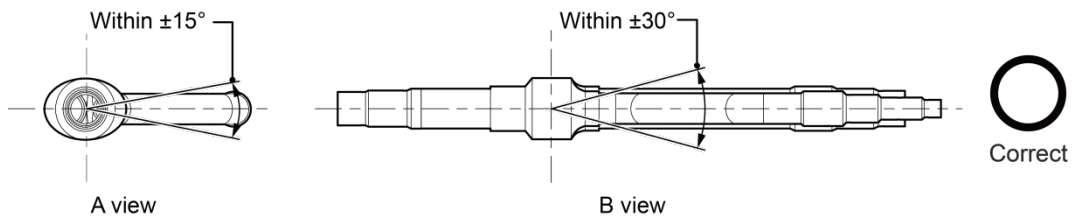

Fig.3.4.4

T- type manifold:

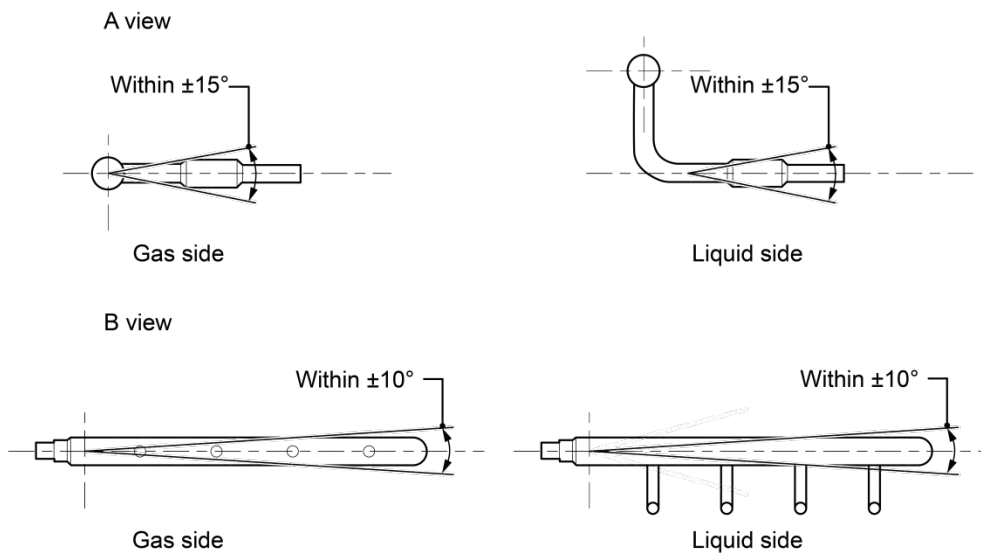

Fig.3.4.5

- Manifold has several pipe sections with different pipe size, which facilitates to match with various copper pipe. Use pipe cutter to cut in the middle of the pipe section with different pipe size. See the Fig. as below.

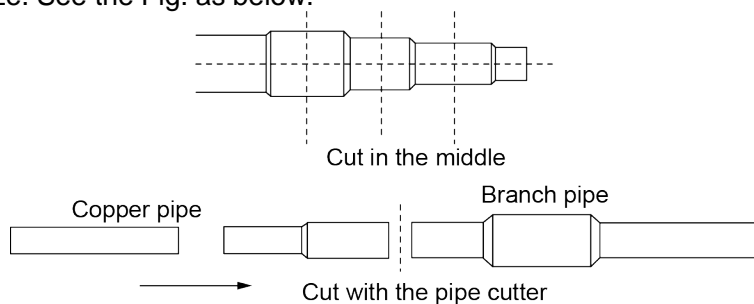

Fig.3.4.6

- The length of a straight pipe between two manifolds cannot be less than 500 mm.

- 5) The length of a straight pipe before the main pipe port of the manifold cannot be less than 500 mm.
- 6) The length of a straight pipe between the branch of the manifold and the IDU cannot be less than 500 mm.

Unit: mm

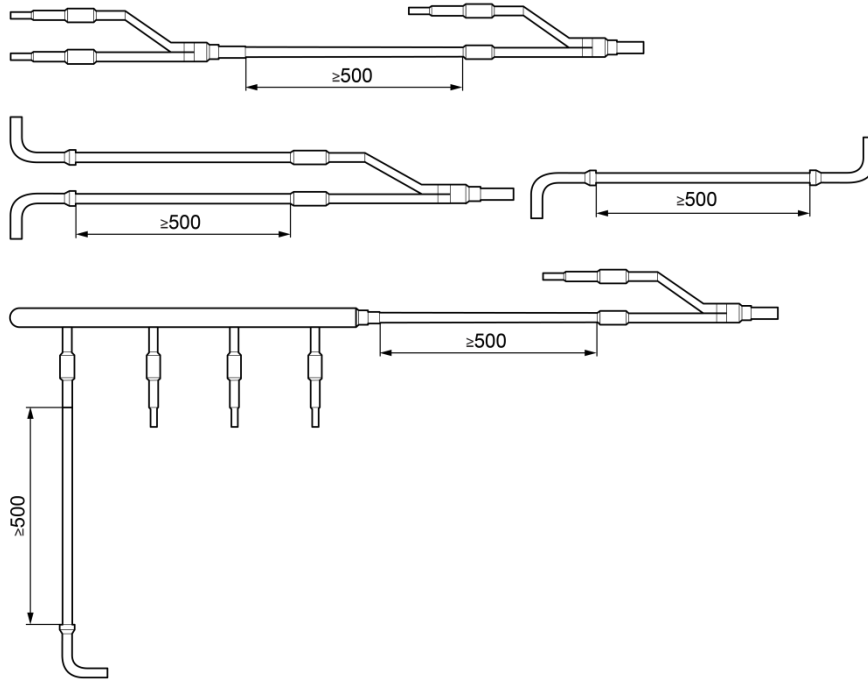

Fig.3.4.7

3.4.3 Fixation of Manifold

- (1) There must be three fixing point for both horizontal and vertical installation of the Y-type manifold.

Fixing point 1: 100 mm on the main inlet manifold from the welding point.

Fixing point 2: 200 mm on the main branched pipe from the welding point.

Fixing point 3: 250 mm on the branched pipe from the welding point.

Unit: mm

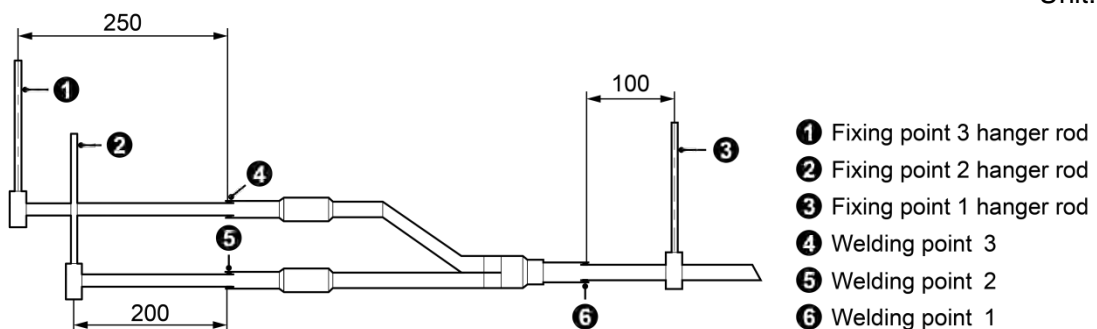

Fig.3.4.8

- (2) Suspend the header to the ceiling, and be sure to install the T-type manifold so that the outlet pipes are horizontal at the lower side.

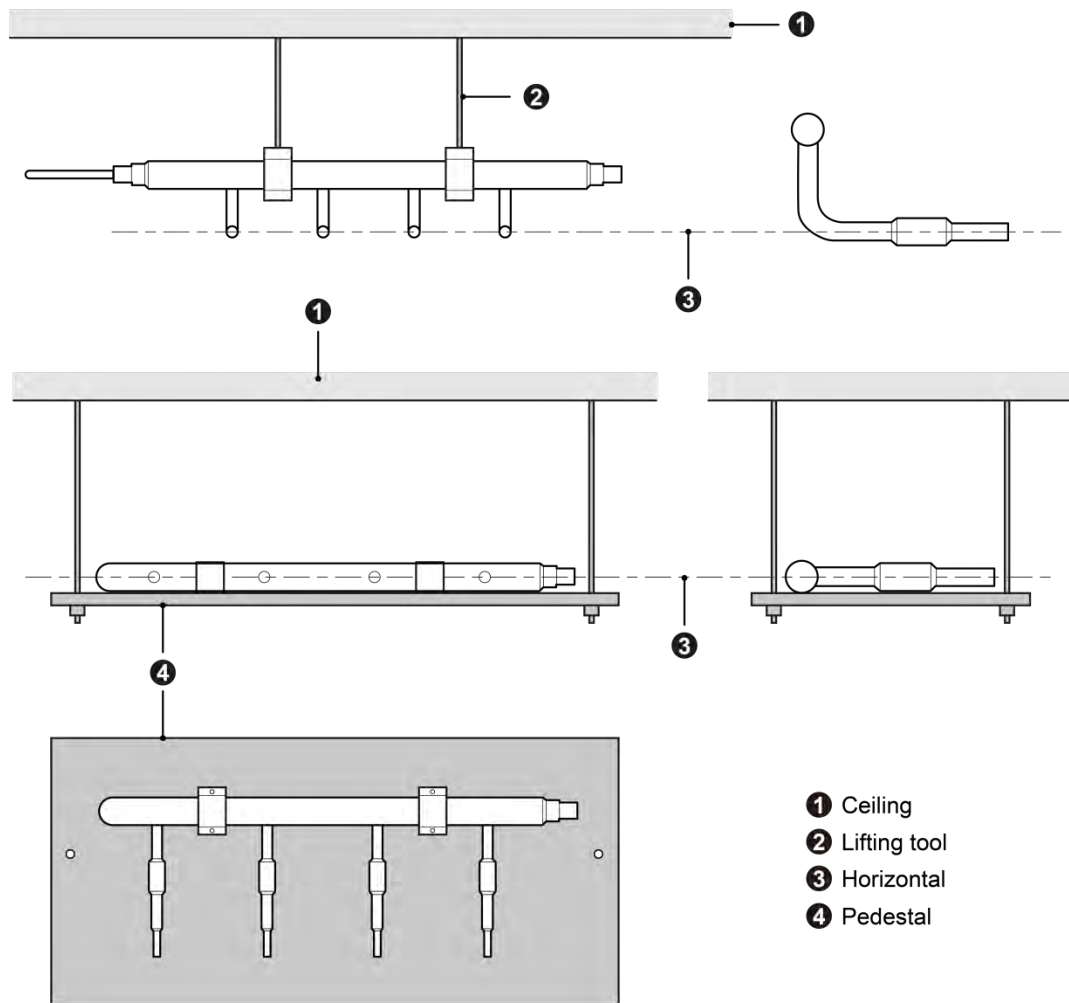

Fig.3.4.9

- (3) The branches of the manifold should be parallel and should not be overlapped.
- (4) The liquid pipe and the gas pipe should have the same pipe length and the same laying circuit.
- (5) Since the structure of the manifold is relatively complicated, it must be rigorous and careful for heat preservation to ensure the tight insulation.

3.4.4 Refrigerant Pipe Insulation

(1) Insulation Material Selection

- 1) Insulation materials should be made of materials that can withstand pipeline temperature: For heat pump unit, liquid pipe should bear 70°C or above, and gas pipe should bear 120°C or above. For cooling only unit, both liquid pipe and gas pipe should bear 70°C or above.

Example: heat-resistant polyethylene foam (resistant to 120°C or more); foamed polyethylene (resistant to 100°C or more).

- 2) When the diameter of the copper pipe is more than or equal to $\Phi 15.9\text{mm}$, the wall thickness of the insulation material is no less than 20mm; when the diameter of the copper pipe is less than 15.9mm, the wall thickness of the insulation material is no less than 15mm.

(2) Pipeline Wrapping

- 1) To avoid condensate or water leakage on connecting pipe, the gas pipe and liquid pipe must be wrapped with thermal insulating material and adhesive pipe for insulation from the air.
- 2) Joints at indoor and outdoor units should be wrapped with insulating material and leave no clearance between pipe and wall. See Fig. 3.4.10.

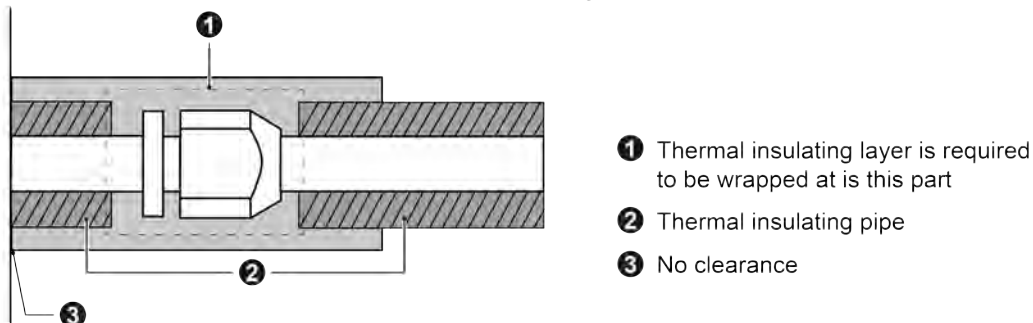

Fig. 3.4.10

- 3) When wrapping the tape, the later circle should cover half of the former one. Don't wrap the tape so tightly, otherwise the insulation effect will be weakened.
- 4) After wrapping the pipe, adopt sealing material to completely fill the hole.

3.4.5 Support and Protection of Pipelines

- (1) The suspended connection pipes should be supported, and the distance between the supports should not exceed 1m.
- (2) The outdoor pipeline should be protected against accidental damage. If the pipeline exceeds 1m, a gusset plate must be added to the pipeline.

3.5 Static Pressure Ventilation Pipe Installation

Refer to this section when a static pressure ventilation duct should be installed for the unit.

3.5.1 Preparation of Static Pressure Ventilation Pipe Installation

- (1) Install the outdoor unit well.
- (2) The steel plate ventilation pipe is designed according to the unit and engineering requirements, and is installed well in accordance with the engineering regulations.
- (3) According to the size of the unit and steel plate ventilation pipe, prepare suitable canvas casing, tin foil paper, steel strip and self-tapping screws, and prepare tools such as electric drill, screwdriver, etc.

3.5.2 Ventilation Pipe Installation

When the effective area of the air inlet is less than 70% of the total inlet area of all outdoor unit, it needs to add an induced draft fan. The total air volume of the induced draft fan is not less than 80% of the total intake air volume.

Note: In the following table, “①” indicates the steel plate ventilation pipe, “②” indicates the outdoor unit, “③” indicates the top cover grille, “④” indicates the canvas casing and “⑤” indicates the steel bar.

The specific operations are as below:

Step	Photo	Operation instruction	Note
Step 1	<p>① Steel plate ventilation pipe ② Outdoor unit</p>	<p>① Select installation position for the outdoor unit and then fix it well; ② Determine the installation position of the ventilation pipe according to the position of the outdoor unit; ③ Refer to the left figure to complete the fabrication and installation of the ventilation pipe.</p>	<p>① Ventilation pipe material: steel plate or iron sheet; ② Ventilation pipe should be purchased by the user.</p>
Step 2	<p>③ Top cover grille</p>	<p>Remove the grille on the top of the top cover assembly.</p>	<p>The top cover grille must be removed; otherwise it will affect the air volume and the operation effect.</p>
Step 3	<p>① Steel plate ventilation pipe ② Outdoor unit ④ Canvas casing</p>	<p>1) Face the inside of the prepared canvas casing outwards, cover it from the top of the unit until the end of the canvas is slightly higher than the unit. 2) Use a steel bar to press tightly the canvas casing ④ around the top case of the unit. Use a hand-operated electric drill to drill holes and fasten the canvas casing onto the unit through steel bar by using tapping screws.</p>	<p>Since drills are required on the top case, the powder coated protective layer on the top case will be damaged. As a result, the anti-corrosion performance of the unit top case will be reduced.</p>

Step	Photo	Operation instruction	Note
Step 4	<p> 1 Steel plate ventilation pipe 2 Outdoor unit 4 Canvas casing 5 Steel bar </p>	1) Pull the canvas casing upside down and press it on the butt flange of the steel pipe ventilation pipe with steel bars; 2) Drill holes with the manual drill and fix them with self-tapping screws; 3) Seal the two butt joints with tinfoil panel and check the reliability of the connection.	—

3.6 Vacuum and Drying of Refrigeration System

3.6.1 Air Tightness Test

(1) Notices

- 1) The range of test pressure gauge for R410A system should be above 4.5MPa.
- 2) Record the pressure gauge readings, ambient temperature and test time.
- 3) Pressure correction: The temperature changes by 1°C, and the pressure changes by 0.01MPa.
- 4) The pressure should remain unchanged to be qualified.
- 5) If it is necessary to maintain pressure for a long time, the pressure should be reduced to 0.5MPa or less. Long periods of high pressure can cause leakage at the weld site and there is safety hazard.
- 6) Before the air tightness test for the refrigerant pipe is completed, it is not allowed to conduct the insulation and wrapping work for any joints between the welding point and the bell mouth of indoor unit. Please increase pressure from the outdoor side pipes at the same time. It is forbidden to increase pressure from one side pipe:

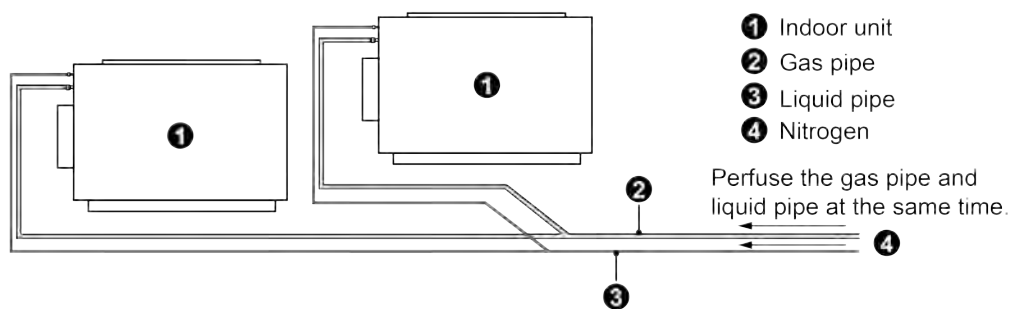

Fig. 3.6.1

Note: All welding points can't be heat-insulated and wrapped until the air tightness test is completed.

(2) Operation procedures for the air tightness test

When leaving the factory, gas pipe, liquid pipe and cut-off valve of outdoor unit have been closed. Please confirm it during installation.

Before the test, a small amount of lubricant oil required by the corresponding system should be smeared at the nut and the end of the pipe. Two wrenches should be used when fixing the nut.

It is not allowed to connect the pipeline of outdoor unit for test during the air tightness test.

The test pressure for R410A system is 4.15MPa. The air tightness test must use nitrogen as the medium and the nitrogen should be dried. Slowly increase the pressure in three steps:

Step 1: slowly increase the pressure to 0.5MPa, stay for 5 minutes and conduct the leakage inspection. You may find big leakage;

Step 2: slowly increase the pressure to 1.5MPa, stay for 5 minutes, conduct the air tightness inspection, and you may find small leakage;

Step 3: Slowly increase the pressure for R410A system to 4.15MPa, stay for 5 minutes and conduct the strength test. You may find small penetration or blisters. After increasing the pressure to the test pressure, hold the pressure for 24 hours, and observe whether the pressure drops. If the pressure does not drop, it is qualified.

3.6.2 Vacuum Drying

(1) Selection requirements for vacuum pumps.

- 1) Can't vacuumize different refrigerant systems with the same vacuum pump.
- 2) The ultimate vacuum of the vacuum pump should be -0.1Mpa.
- 3) The air displacement of the vacuum pump should be above 4L/s.
- 4) The accuracy of the vacuum pump should be above 0.02mmHg.
- 5) The system vacuum pump must have a check valve.

(2) Operation procedures of vacuum drying.

- 1) Before vacuuming, confirm that the stop valves of gas pipe and liquid pipe are at closed status.
- 2) Connect the regulating valve and vacuum pump to the inspection joint of the gas pipe valve and liquid pipe valve valves with a filling tube.
- 3) Vacuumize it for 4 hours, and check if the vacuum degree reaches -0.1MPa or above. If not, there may be a leak. It needs to conduct the leakage test once again. If there is no leak, vacuumize it for another 2 hours.
- 4) If the vacuum degree cannot be maintained by two times of vacuumings, you can confirm that there is water inside the pipeline under the condition that there is no leakage. At this time, the water should be removed by vacuum destruction. The specific method is: fill the pipeline with 0.05MPa nitrogen gas, vacuumize it for 2 hours, and keep vacuum for 1 hour. If it still can't reach the vacuum degree of -0.1MPa, repeat this operation until the water is drained.
- 5) After vacuuming, close the valve of the regulating valve and stop vacuuming for 1 hour. Confirm that the pressure of the regulating valve has not risen.

(3) Notices for vacuum drying

- 1) Vacuumize it from both the gas pipe and liquid at the same time.

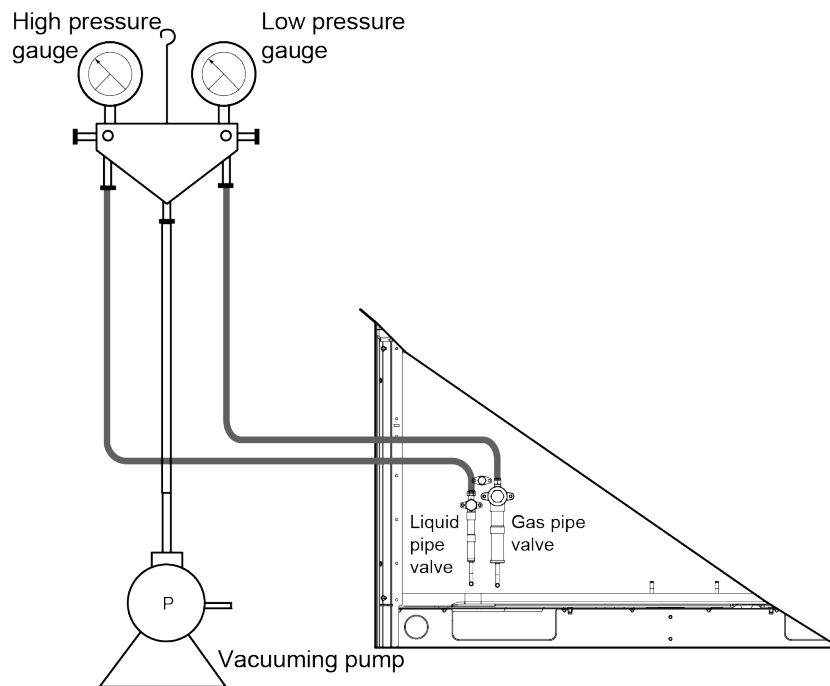

Fig. 3.6.2

- 2) When the vacuum pump is turned off to stop vacuuming, the valve should be closed at first and then cut off the power for the vacuum pump.
- 3) Keep the vacuum for 2 hours and confirm that the pressure of the vacuum gauge has not risen.

3.7 Additional Refrigerant Charging

3.7.1 Calculation Method of Adding Refrigerant

Total refrigerant charging amount $R = \text{Pipeline charging amount } A + \Sigma \text{ charging amount } B \text{ of every module.}$

(1) Pipeline charging amount:

Pipeline charging amount $A = \Sigma \text{ Liquid pipe length} \times \text{refrigerant charging amount of every 1m liquid pipe}$

Diameter of liquid pipe (mm)	Φ28.6	Φ25.4	Φ22.2	Φ19.05	Φ15.9	Φ12.7	Φ9.52	Φ6.35
kg/m	0.680	0.520	0.350	0.250	0.170	0.110	0.054	0.022

(2) Σ Refrigerant charging amount B of every module

Refrigerant charging amount B of every module (kg) ②		Module capacity(kW)							
IDU/ODU rated capacity collocation ratio C ①	Quantity of indoor unit	22.4	28	33.5	40	45	50.4	56	61.5
50% ≤ C ≤ 70%	<4	0	0	0	0	0	0	0	0
	≥4	0.5	1	1	1	1	0.5	1	1.5
70% < C ≤ 90%	<4	0.5	1	1	2	2	1.5	2	2
	≥4	1	1	1	2	2	2.5	3	3.5
90% < C ≤ 105%	<4	1	1	1	2	2	2.5	3	3.5
	≥4	2	2	2	4	4	4	5	5
105% < C ≤ 135%	<4	2	2	2	3	3	3.5	4	4
	≥4	3.5	4	4	5	5	5.5	6	6

**NOTES!**

- ① Rated capacity configuration rate of indoor unit and outdoor unit $C = \text{sum of indoor unit rated cooling capacity} / \text{sum of outdoor unit rated cooling capacity}$.
- ② If all indoor units are all fresh air indoor units, the added refrigerant amount for each module B is 0kg.
- ③ If all fresh air indoor units are mixed with the general VRF indoor units, charge the refrigerant according to the refrigerant-charging method of the general indoor unit.

For example1:

Outdoor unit consists of one 28kW module and one 45kW module. Five 14kW duct type units are used as indoor units.

IDU/ODU rated capacity collocation ratio $C = 14.0 \times 5 / (28.0 + 45.0) = 96\%$. The quantity of included IDUs is more than 4 sets. Please refer to the above table.

Additional refrigerant quantity B for 28kW module is 2.0 kg.

Additional refrigerant quantity B for 45kw module is 4 kg.

So, $\sum \text{Refrigerant charging amount B of every module} = 2.0 + 4 = 6 \text{ kg}$.

Suppose the Pipeline charging amount $A = \sum \text{Liquid pipe length} \times \text{refrigerant charging amount of every 1m liquid pipe} = 20 \text{ kg}$.

Total refrigerant charging amount $R = 20 + 6 = 26 \text{ kg}$.

For example 2:

Outdoor unit is a 45kW module and the indoor unit is a 45kW fresh air unit. The quantity (B) of refrigerant added to this module is 0kg.

So, $\sum \text{Refrigerant charging amount B of every module} = 0 \text{ kg}$.

Suppose the Pipeline charging amount $A = \sum \text{Liquid pipe length} \times \text{refrigerant charging amount of every 1m liquid pipe} = 5 \text{ kg}$.

Total refrigerant charging amount $R = 5 + 0 = 5 \text{ kg}$.

Modular combination of outdoor unit subjects to combinations that is currently available.

3.7.2 Refrigerant-charging Method

Refrigerant charging for multi VRF unit includes two parts: pre-charging and start-up charging.

(1) Pre-charging of refrigerant.

Step 1: Connect the pipe of high pressure gauge of the pressure gauge to the detection port of liquid pipe, the pipe of low pressure gauge to the detection port of gas pipe valve, and the pipe of intermediate pressure gauge to the vacuum pump. Put through the power for the vacuum pump to conduct the vacuum drying work.

Step 2: Once vacuum drying is completed, close the high pressure gauge valve and the low pressure gauge valve. Disassemble the intermediate gauge pipe and the vacuum pump connection end, and then connect the refrigerant tank.

Step 3: Properly loosen the pipe of intermediate gauge and the connection end of pressure gauge, slightly open the refrigerant tank valve, and empty the pipe of intermediate gauge. After that,

retighten the joint and open the refrigerant tank valve.

Step 4: If the refrigerant tank itself does not have a siphon, then the refrigerant tank needs to be inverted and placed on the electronic scale to record the current weight of m_1 ; if the refrigerant tank itself has a siphon, the refrigerant tank should be kept in an upright state, and record the current weight of m_1 .

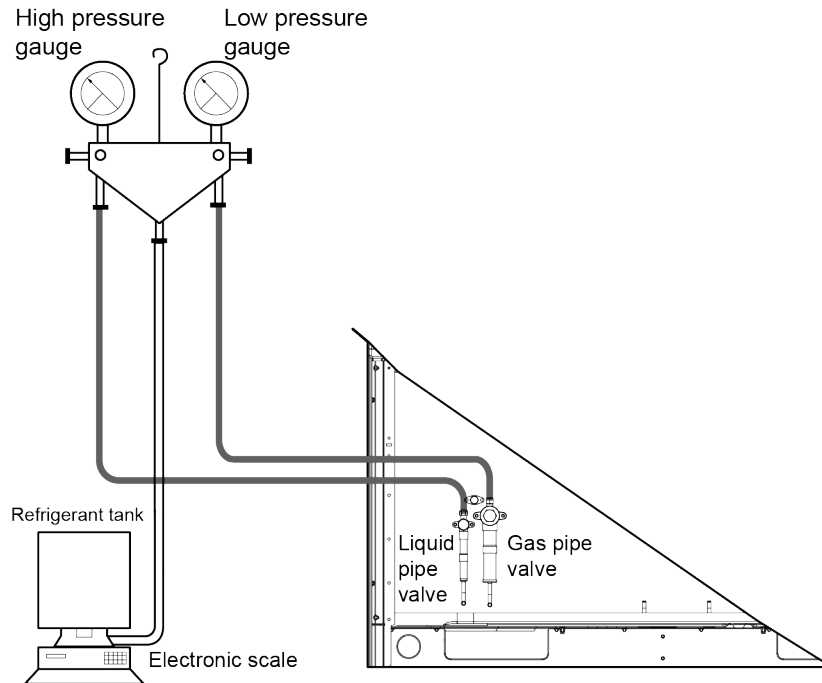

Fig. 3.7.1

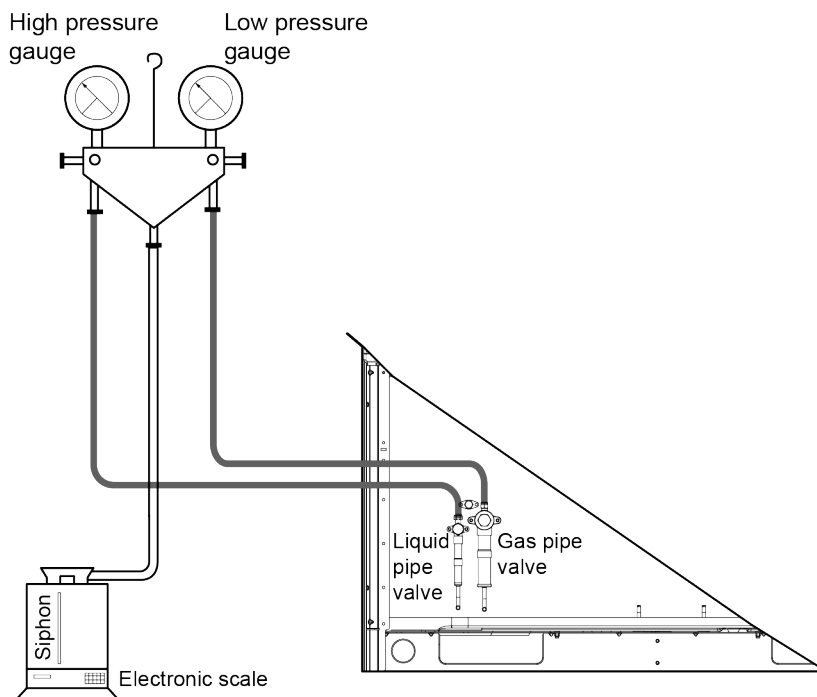

Fig. 3.7.2

Step 5: Open the high pressure gauge valve (the low pressure gauge valve remains closed), charge the system with refrigerant, and record the weight change of the refrigerant tank.

Step 6: When refrigerant tank is over and the refrigerant can't be charged to the system any more, record the current weight of m_2 .

Step 7: Close the high pressure gauge valve and replace the refrigerant tank.

Step 8: Re-execute "step 3".

Step 9: Repeat "step 5" and "step 6" to record the weight of m3 before charging refrigerant and the weight of m4 after charging refrigerant.

Step 10: If the refrigerant cannot be continuously charged into the system and the calculated added amount of refrigerant has not been fully charged into the system, record current total pre-charging amount:

$$m=(m1-m2) +(m3-m4) +...+(mn-1-mn)$$

$$\text{Remained refrigerant for start-up charging } m' = M - m$$

"M" is the calculated total required refrigerant-charging volume.

If the amount of pre-charging refrigerant "m" has reached the total added amount of refrigerant for the system, close the refrigerant tank valve immediately to complete the refrigerant-charging work. Skip to the "step 11".

Step 11: Complete the refrigerant-charging work and remove the pressure gauge, etc.

(2) Start-up charging of refrigerant.

Step 1: Close the refrigerant tank valve and reconnect the pipe of pressure gauge. Remove the pipe of low pressure gauge from the check port of gas pipe valve and connect it to the low pressure check valve (as shown in the Fig.).

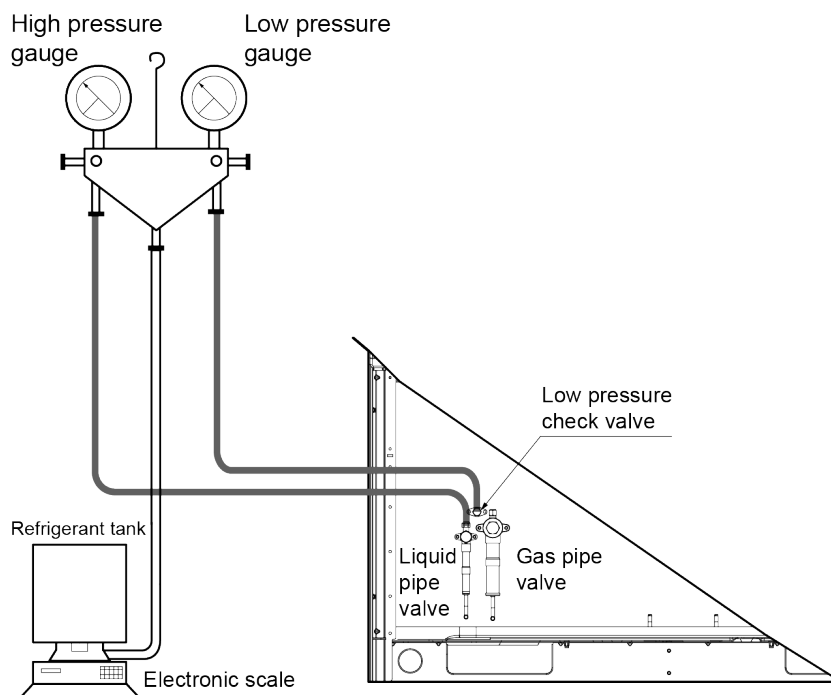

Fig. 3.7.3

Step 2: Fully open the liquid pipe valve and gas pipe valve of each module.

Step 3: Make the complete unit enter into debugging operation by the debugging software or the main board of outdoor unit. (see the debugging part for the specific operation).

Step 4: When it comes to the procedure of charging refrigerant, open the refrigerant tank valve and charge the residual refrigerant "m".

Step 5: When all refrigerant has been charged, close the refrigerant tank valve and wait until the

automatic debugging for the complete unit is finished.

Step 6: Once debugging is finished, disassemble the pressure gauge, etc., to complete the refrigerant-charging work.

3.7.3 Precautions on Refrigerant Leakage

- (1) Personnel related to air conditioning engineering design and installation operators must abide by the safety requirement for preventing refrigerant leakage specified in local laws and regulations.
- (2) Multi VRF unit adopts R410A refrigerant. When the unit is installed in the place where there are people, the refrigerant must not exceed the maximum allowable concentration. Otherwise, people involved can be stifled by the refrigerant. For example the maximum allowed concentration level of refrigerant to a humanly space for R410A according to the appropriate European Standard is limited to 0.44 kg/m^3 .

The maximum amount of refrigerant(kg)in the system = The volume of the room (m^3) xThe maximum allowed concentration level of refrigerant (kg/m^3)

Total amount of refrigerant (kg) in the system = Total additional charging amount (kg) + Amount of refrigerant (kg) which is charged before leaving the factory (for the system consisting of multiple modules in parallel, the accumulative charge quantity of modules before leaving the factory is used)

Total amount of refrigerant (kg) in the system \leq the maximum amount of refrigerant (kg) in the system

- (3) When the total amount of refrigerant in the system is more than the maximum amount of refrigerant, the cooling system should be designed again. In this case, the cooling system can also be separated into several cooling systems with small capacity, or add corresponding ventilation measures or alarming display.

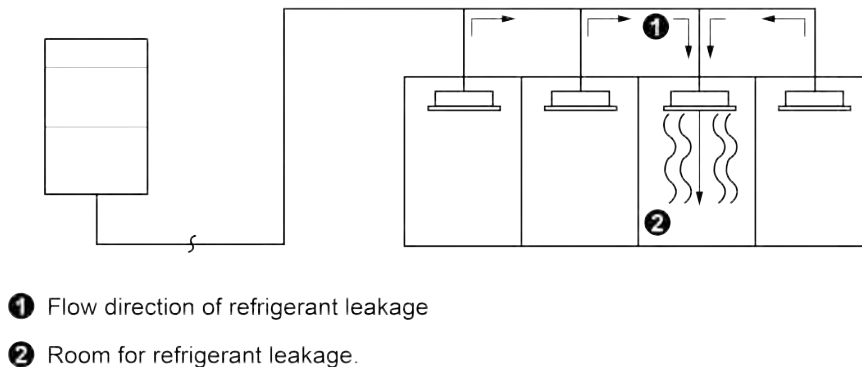

Fig. 3.6.6

Since the concentration of refrigerant is greater than that of air, pay attention to the spaces where the refrigerant may residue, for example, the basement.

3.8 Electrical Installation

3.8.1 Notices for Electrical Installation

- (1) All electrical installations must be performed by professionally qualified electricians in accordance with local laws, regulations and corresponding instructions. All parts, materials and electrical operations provided must comply with local regulations.
- (2) The unit must be reliably grounded, with grounding resistance smaller than 4Ω .

- (3) The special power supply for air conditioning unit must be used, and the power supply specifications must be consistent with the rated power supply of the unit.
- (4) The power cord must be reliably secured. It is forbidden to pull the power cord forcibly to prevent the wiring terminal from being stressed; if the length of power cord is insufficient or the power cord is damaged, it is forbidden to connect two power cords together. Please apply a new power cord that meets the local regulations.
- (5) The unit must be equipped with the circuit breaker and the electric leakage protection device. The circuit breaker should have both magnetic tripping and thermal tripping functions.
- (6) It is forbidden to take power from the inside of the unit, which may cause fire hazard.
- (7) When wiring on site, please also refer to the circuit diagram attached on the unit. Before all electrical installations are completed, it is forbidden to put through the power supply (circuit breaker and electric leakage protection device on the circuit).

3.8.2 Electrical Parameters

Every unit should have corresponding short-circuit and overload protection. And also a main switch is required to control power supply or disconnection. See Fig. 3.8.1.

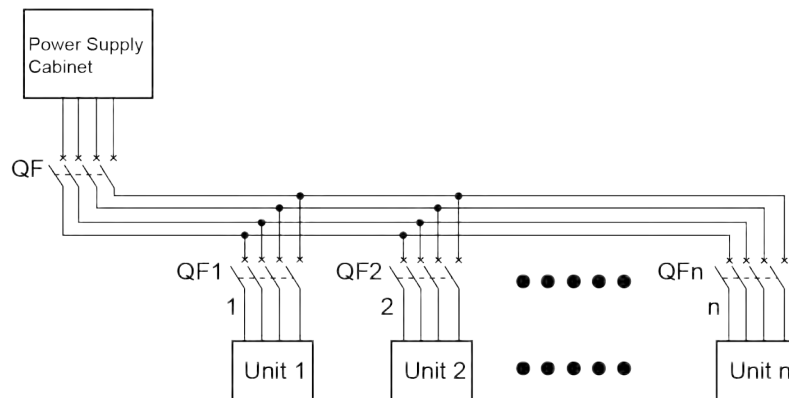

Fig. 3.8.1

Please refer to the following table for outdoor unit power cord specifications and circuit breakers.

Model	Combination method	Power supply	Capacity of circuit breaker of each combination module (A)	Minimum cross-sectional area of grounding wire (mm ²)	Recommended wire (cross-sectional area) (mm ²)
AMV6-O224	-	380-415V 3N~50/60Hz	25	2.5	2.5×5
AMV6-O280	-	380-415V 3N~50/60Hz	25	2.5	2.5×5
AMV6-O335	-	380-415V 3N~50/60Hz	25	4.0	4.0×5
AMV6-O400	-	380-415V 3N~50/60Hz	40	6.0	6.0×5
AMV6-O450	-	380-415V 3N~50/60Hz	40	6.0	6.0×5
AMV6-O504	-	380-415V 3N~50/60Hz	50	10.0	10.0×5
AMV6-O560	-	380-415V 3N~50/60Hz	50	10.0	10.0×5

Model	Combination method	Power supply	Capacity of circuit breaker of each combination module (A)	Minimum cross-sectional area of grounding wire (mm ²)	Recommended wire (cross-sectional area) (mm ²)
AMV6-O615	-	380-415V 3N~50/60Hz	50	10.0	10.0×5
AMV6-O680	280+400	380-415V 3N~50/60Hz	25+40	2.5+6.0	2.5×5+6.0×5
AMV6-O730	280+450	380-415V 3N~50/60Hz	25+40	2.5+6.0	2.5×5+6.0×5
AMV6-O784	280+504	380-415V 3N~50/60Hz	25+50	2.5+10.0	2.5×5+10.0×5
AMV6-O840	280+560	380-415V 3N~50/60Hz	25+50	2.5+10.0	2.5×5+10.0×5
AMV6-O895	280+615	380-415V 3N~50/60Hz	25+50	2.5+10.0	2.5×5+10.0×5
AMV6-O950	335+615	380-415V 3N~50/60Hz	25+50	4.0+10.0	4.0×5+10.0×5
AMV6-O1015	400+615	380-415V 3N~50/60Hz	40+50	6.0+10.0	6.0×5+10.0×5
AMV6-O1065	450+615	380-415V 3N~50/60Hz	40+50	6.0+10.0	6.0×5+10.0×5
AMV6-O1119	504+615	380-415V 3N~50/60Hz	50+50	10.0+10.0	10.0×5+10.0×5
AMV6-O1175	560+615	380-415V 3N~50/60Hz	50+50	10.0+10.0	10.0×5+10.0×5
AMV6-O1230	615+615	380-415V 3N~50/60Hz	50+50	10.0+10.0	10.0×5+10.0×5
AMV6-O1290	280+450+560	380-415V 3N~50/60Hz	25+40+50	2.5+6.0+10.0	2.5×5+6.0×5+10.0×5
AMV6-O1345	280+450+615	380-415V 3N~50/60Hz	25+40+50	2.5+6.0+10.0	2.5×5+6.0×5+10.0×5
AMV6-O1400	335+450+615	380-415V 3N~50/60Hz	25+40+50	4.0+6.0+10.0	4.0×5+6.0×5+10.0×5
AMV6-O1455	280+560+615	380-415V 3N~50/60Hz	25+50+50	2.5+10.0+10.0	2.5×5+10.0×5+10.0×5
AMV6-O1510	280+615+615	380-415V 3N~50/60Hz	25+50+50	2.5+10.0+10.0	2.5×5+10.0×5+10.0×5
AMV6-O1565	335+615+615	380-415V 3N~50/60Hz	25+50+50	4.0+10.0+10.0	4.0×5+10.0×5+10.0×5
AMV6-O1630	400+615+615	380-415V 3N~50/60Hz	40+50+50	6.0+10.0+10.0	6.0×5+10.0×5+10.0×5
AMV6-O1680	450+615+615	380-415V 3N~50/60Hz	40+50+50	6.0+10.0+10.0	6.0×5+10.0×5+10.0×5
AMV6-O1734	504+615+615	380-415V 3N~50/60Hz	50+50+50	10.0+10.0+10.0	10.0×5+10.0×5+10.0×5

DC Inverter Multi VRF System

Model	Combination method	Power supply	Capacity of circuit breaker of each combination module (A)	Minimum cross-sectional area of grounding wire (mm ²)	Recommended wire (cross-sectional area) (mm ²)
AMV6-O1790	560+615+615	380-415V 3N~50/60Hz	50+50+50	10.0+10.0+10.0	10.0×5+10.0×5+10.0×5
AMV6-O1845	615+615+615	380-415V 3N~50/60Hz	50+50+50	10.0+10.0+10.0	10.0×5+10.0×5+10.0×5
AMV6-O1905	280+450+560+615	380-415V 3N~50/60Hz	25+40+50+50	2.5+6.0+10.0+10.0	2.5×5+6.0×5+10.0×5+10.0×5
AMV6-O1959	280+504+560+615	380-415V 3N~50/60Hz	25+50+50+50	2.5+10.0+10.0+10.0	2.5×5+10.0×5+10.0×5+10.0×5
AMV6-O2015	280+560+560+615	380-415V 3N~50/60Hz	25+50+50+50	2.5+10.0+10.0+10.0	2.5×5+10.0×5+10.0×5+10.0×5
AMV6-O2070	280+560+615+615	380-415V 3N~50/60Hz	25+50+50+50	2.5+10.0+10.0+10.0	2.5×5+10.0×5+10.0×5+10.0×5
AMV6-O2125	280+615+615+615	380-415V 3N~50/60Hz	25+50+50+50	2.5+10.0+10.0+10.0	2.5×5+10.0×5+10.0×5+10.0×5
AMV6-O2180	335+615+615+615	380-415V 3N~50/60Hz	25+50+50+50	4.0+10.0+10.0+10.0	4.0×5+10.0×5+10.0×5+10.0×5
AMV6-O2245	400+615+615+615	380-415V 3N~50/60Hz	40+50+50+50	6.0+10.0+10.0+10.0	6.0×5+10.0×5+10.0×5+10.0×5
AMV6-O2295	450+615+615+615	380-415V 3N~50/60Hz	40+50+50+50	6.0+10.0+10.0+10.0	6.0×5+10.0×5+10.0×5+10.0×5
AMV6-O2349	504+615+615+615	380-415V 3N~50/60Hz	50+50+50+50	10.0+10.0+10.0+10.0	10.0×5+10.0×5+10.0×5+10.0×5
AMV6-O2405	560+615+615+615	380-415V 3N~50/60Hz	50+50+50+50	10.0+10.0+10.0+10.0	10.0×5+10.0×5+10.0×5+10.0×5
AMV6-O2460	615+615+615+615	380-415V 3N~50/60Hz	50+50+50+50	10.0+10.0+10.0+10.0	10.0×5+10.0×5+10.0×5+10.0×5



NOTES!

- ① Selection of circuit breaker and power cord is based upon unit's maximum power (maximum current).
- ② Specification of power cord is based on the working condition where ambient temperature is 40°C and multi-core copper cable with working temperature of 90°C is lying on the surface of slot. If working condition changes, please adjust the specification according to national standard.
- ③ Copper-core cable which complies with local regulations must be applied.
- ④ The engineering wiring should meet IEC 60364-5-52 regulations. Ensure that the circuit voltage drop meets the requirements and the voltage of the equipment is not lower than the lower declared limit of the equipment.

- ⑤ Specification of circuit breaker is based on the working condition where ambient temperature of circuit breaker is 40°C. If working condition changes, please adjust according to the circuit breaker specification.
- ⑥ The circuit breaker should include magnetic trip function and thermal trip function so that system can be protected from short circuit and overload.
- ⑦ An all-pole disconnection switch having a contact separation of at least 3mm in all poles should be connected in fixed wiring.

3.8.3 Power Cord Connection

3.8.3.1 Power Cord Installation Procedures

Step 1: Pass the external power cord through the wire-passing rubber gasket of the chassis seal board, and connect the power cord's "L1, L2, L3, N, PE" to the power wiring board marked with "L1, L2, L3, N, PE" respectively and the grounding screw beside the power wiring board.

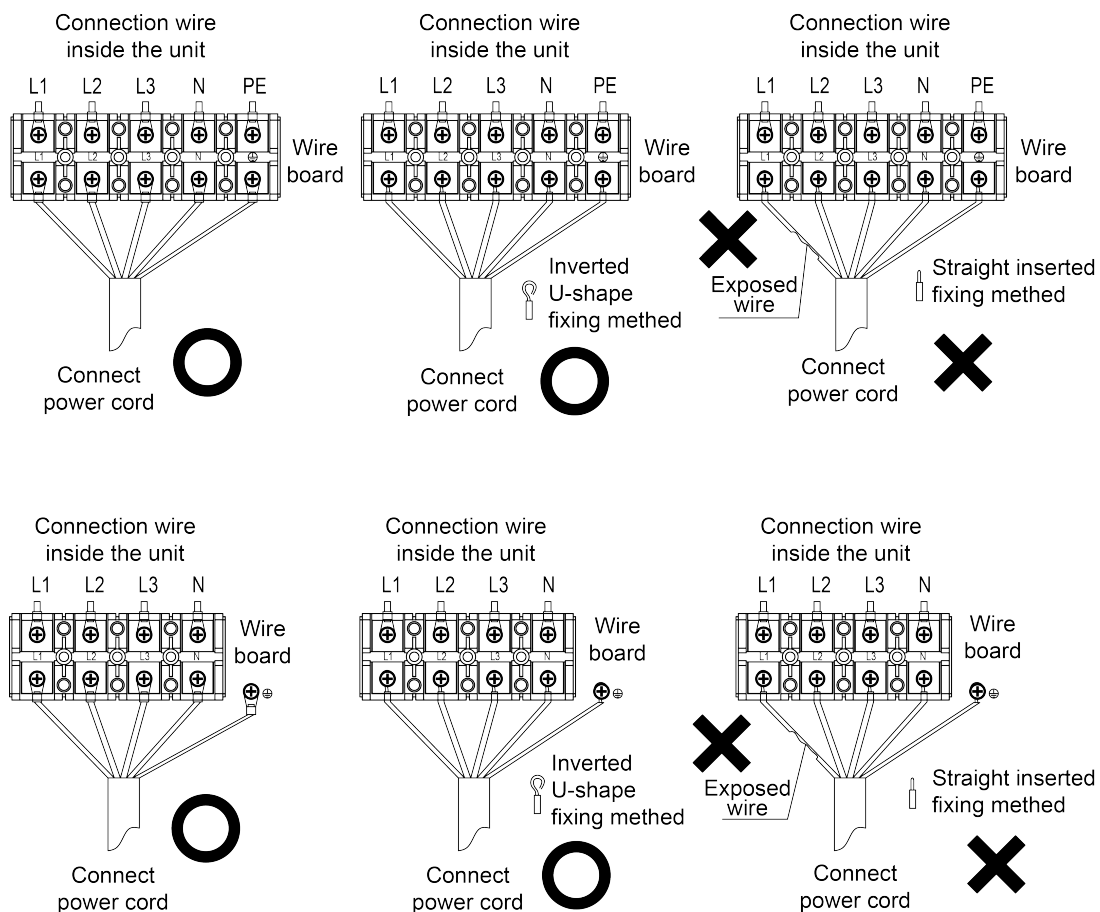

Fig. 3.8.2

Step 2: Tighten the cable with a cable tie.

Step 3: Please refer to the engineering wiring mark on the unit for the power cord connection.



WARNING!

When the power cord and the communication line pass through the wire hole, they must be equipped with wire rubber ring.

3.8.3.2 External Wiring Diagram

Each unit should be equipped with a circuit breaker for short circuit and abnormal overload protection. The circuit breaker is normally closed.

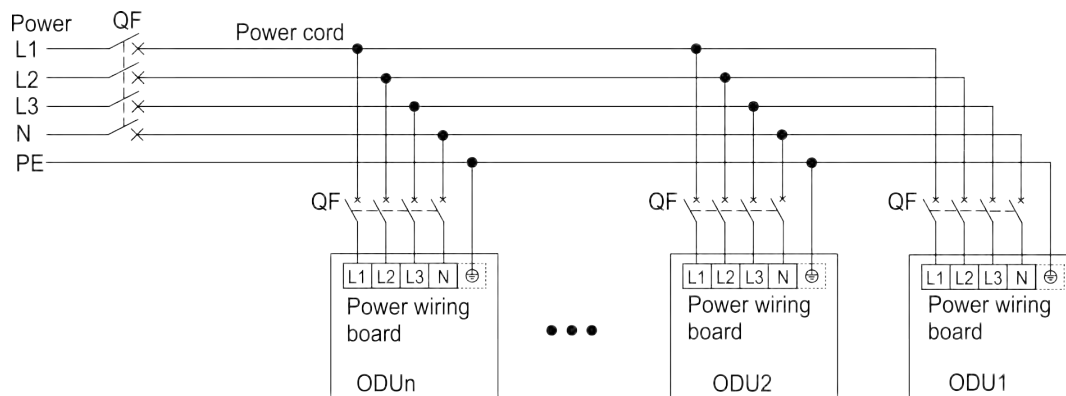

Notes:

The maximum outdoor unit quantity “n” is decided by the combination from of outdoor unit. Please refer to the actual requirement of unit for the earthing position.

Fig. 3.8.3



NOTE!

The maximum connection number “N” of outdoor unit and the maximum connection number “n” of indoor unit are decided by the combination method of outdoor unit. For details, please refer to the part of unit capacity configuration.

3.8.4 Wiring Diagram

Refer to the wiring diagram attached on the unit.

3.9 Communication Line Connection

Adopt CAN bus communication mode between indoor unit and outdoor unit as well among indoor units.

3.9.1 Connection Method of Communication Line Terminal

Communication connections adopts screws for fixing.

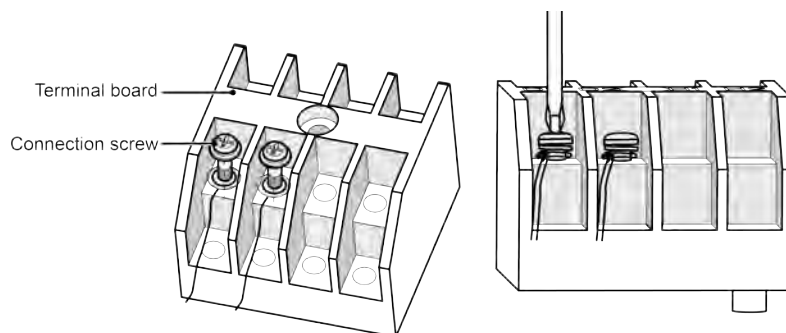

Fig. 3.9.1

3.9.2 Communication Material Selection



If the air conditioning unit is installed in a place with strong electromagnetic interference, the communication line between the indoor unit and the wired controller must adopt shielded wires; the communication line between indoor units (between indoor unit and outdoor unit) must use the shielded twisted pairs.

(1) Selection of communication line between indoor unit and wired controller.

Wire type	Total length of communication wire between indoor unit and wired controller L(m)	Wire diameter (mm ²)	Wire standard	Remark
Light / ordinary PVC sheathed twisted copper core cord	L≤250	2×0.75~2×1.25	IEC 60227-5:2007	The length of communication line can't exceed 250m.
Shielded light/ordinary PVC sheathed twisted copper core cord	L≤250	2×0.75~2×1.25	IEC 60227-5:2007	When the installation environment of the unit is in strong magnetic or strong interference, the shielded wires shall be used.

The connection between the indoor unit and the wired controller is shown as below:

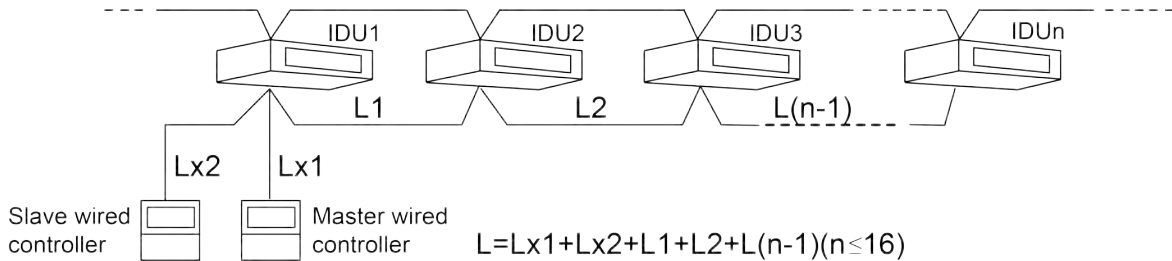

Fig. 3.9.2

(2) Selection of communication line between outdoor unit and indoor unit.

Wire type	Length of communication wire between indoor unit and another indoor/outdoor unit(m)	Wire diameter (mm ²)	Wire standard	Remark
Light/ordinary PVC sheathed twisted copper core cord	L≤1000	≥2×0.75	IEC 60227-5:2007	If the wire diameter is increased to 2×1mm ² , the length of communication line can't be increased, while the length of the communication line can't be more than 1500m.
Shielded light/ordinary PVC sheathed twisted copper core cord	L≤1000	≥2×0.75	IEC 60227-5:2007	When the installation environment of the unit is in strong magnetic or strong interference, the shielded wires shall be used.

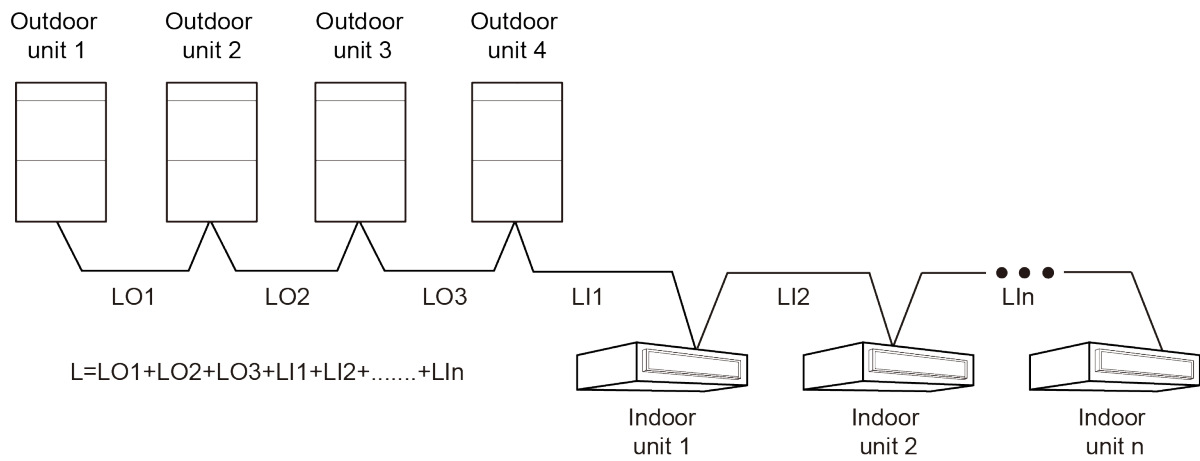

Fig. 3.9.3

3.9.3 Communication Line Connection

Communication bus connection between indoor unit and outdoor unit must be connected in series, rather than star connection; the endmost indoor unit of communication bus between indoor unit and outdoor unit must connect with the communication matching resistor(in the outdoor unit plastic bag); the fresh air indoor unit is not recommended to be set as the main indoor unit.

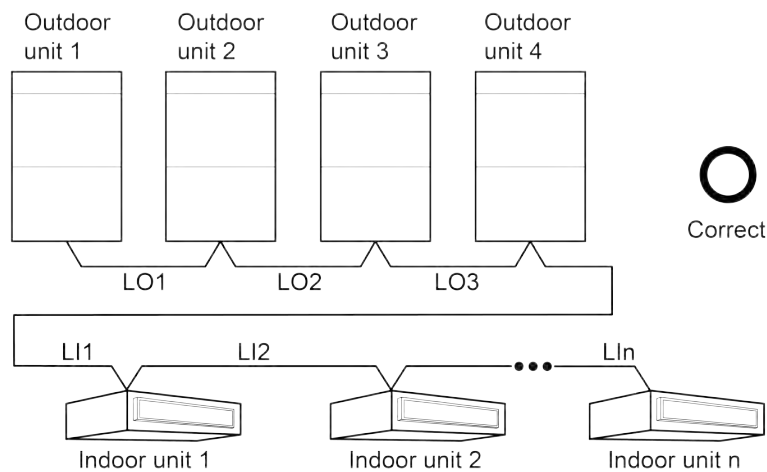

Fig. 3.9.4

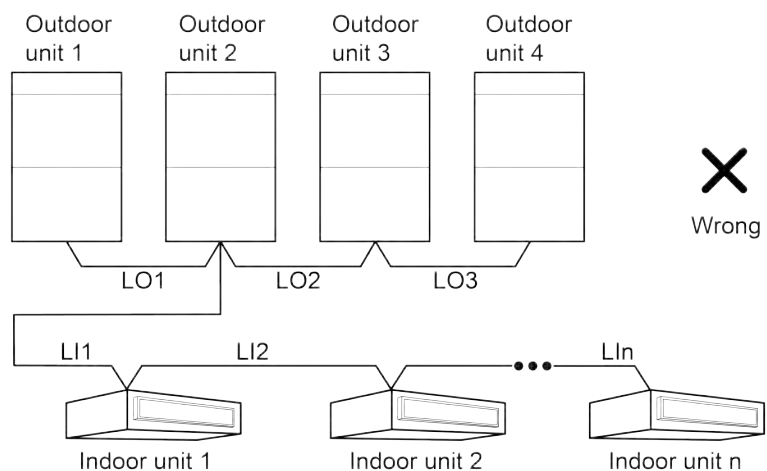

Fig. 3.9.5

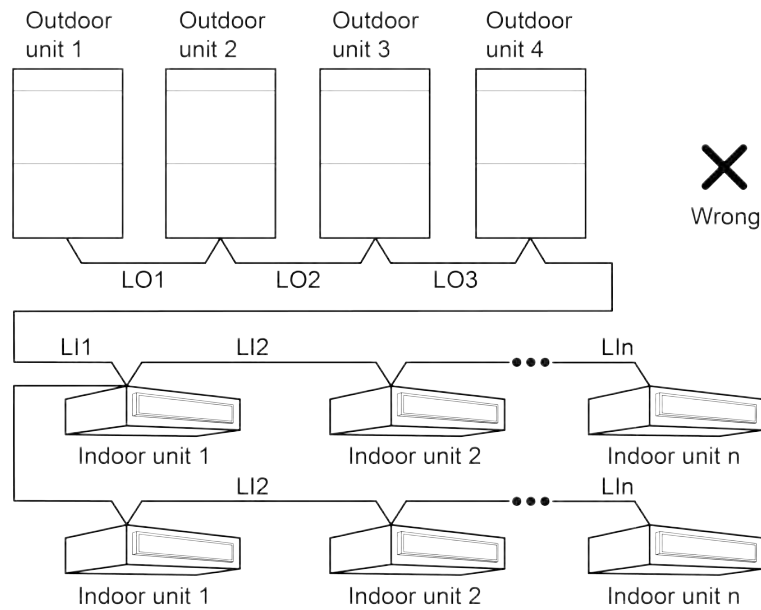

Fig. 3.9.6

3.9.4 Communication Address Setting

The indoor unit and outdoor unit adopt automatic addressing technology. It is not necessary to manually set the address code. It only needs to set the main module and centralized control address (set it when centralized control of multiple refrigeration systems is required) .

3.9.5 Communication Connection between IDU and ODU

Communication between IDU and ODU is connected through the D1/D2 port of the communication terminal block.

Central control communication among multiple multi VRF system is connected through G1 and G2 ports on the communication terminal block of main module.

Below are the connection graphics of single unit and modular units:

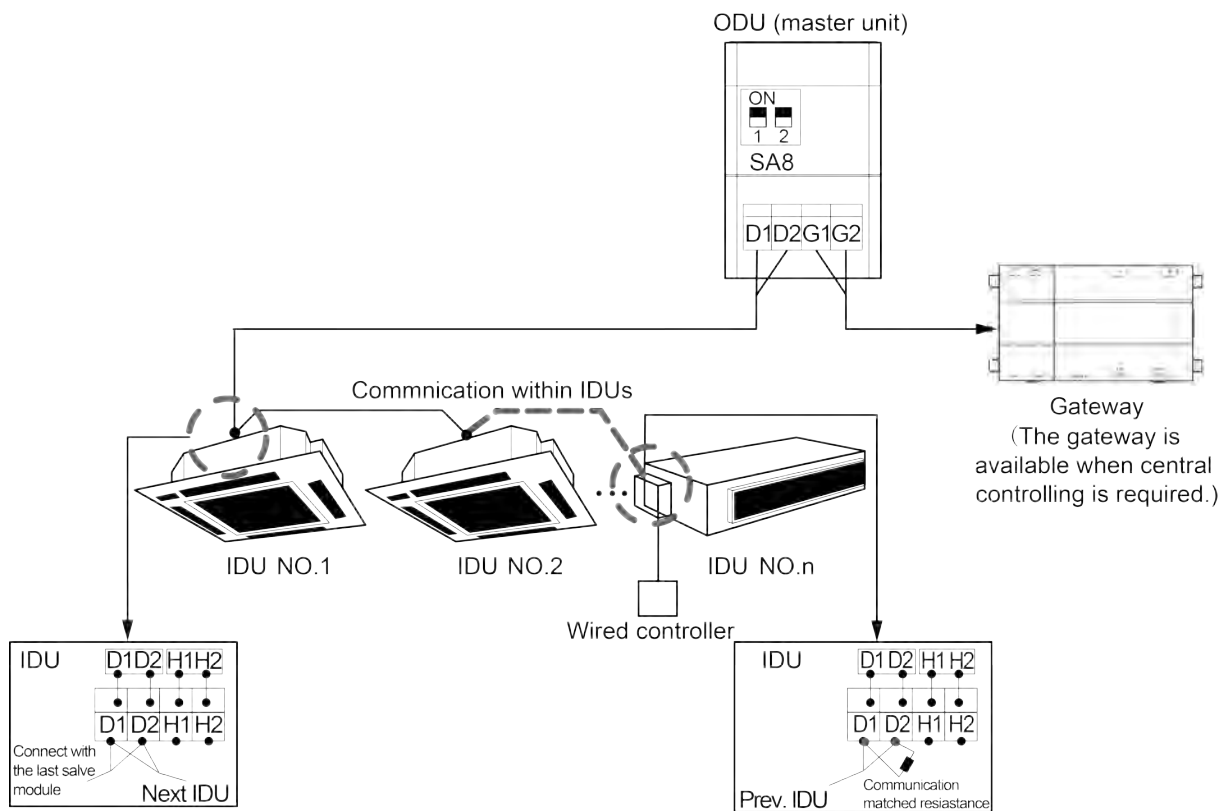

Fig. 3.9.7 Connection of single unit

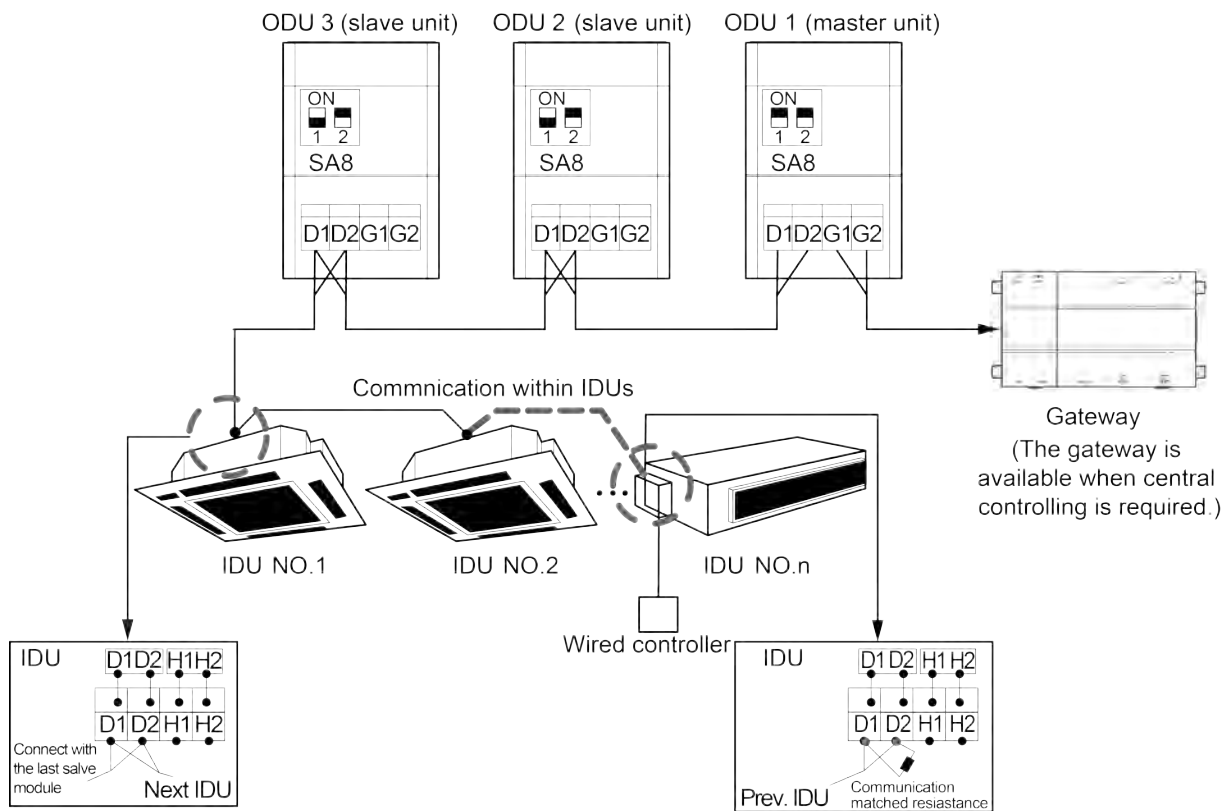

Fig. 3.9.8 Connection of modular units



NOTES!

- ① As for modular indoor unit, if there are multiple outdoor unit modules, the master module must be the first outdoor unit module on the communication line, and it must not connect to the indoor unit (main module is set by SA8 of indoor unit main board).
- ② As for modular outdoor unit, if there are multiple outdoor unit modules, the indoor unit must be connected to the last outdoor unit's slave module (slave unit is set by SA8 of indoor unit main board).
- ③ The communication line and the power cord must be routed separately to avoid interference.
- ④ The communication line must be of suitable length and must not be connected.
- ⑤ The indoor unit must be connected in series, and the last indoor unit must be connected to the communication matching resistor (provided in the outdoor unit parts list).
- ⑥ Please refer to the relevant manual for the centralized controller wiring method and settings.

3.9.6 Communication Connection between Indoor Unit and Wired Controller

There are four types of connection between the indoor unit and wired controller, as shown in the following figure:

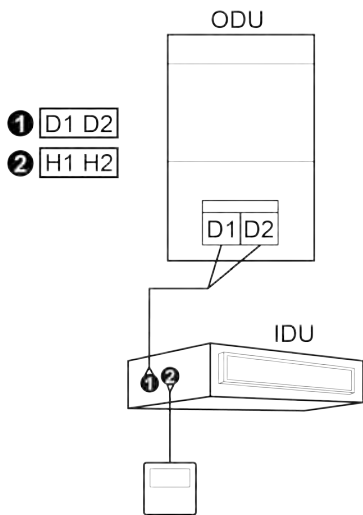

Fig. 3.9.9 One wired controller controls one IDU

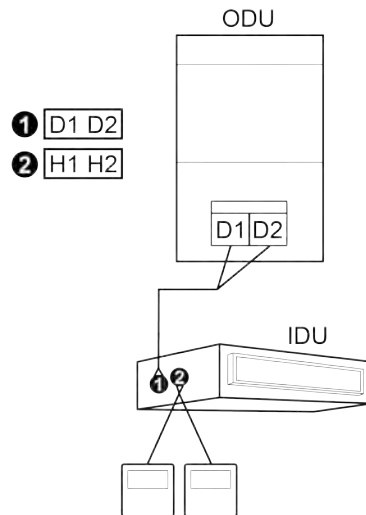

Fig. 3.9.10 Two wired controllers control one IDU

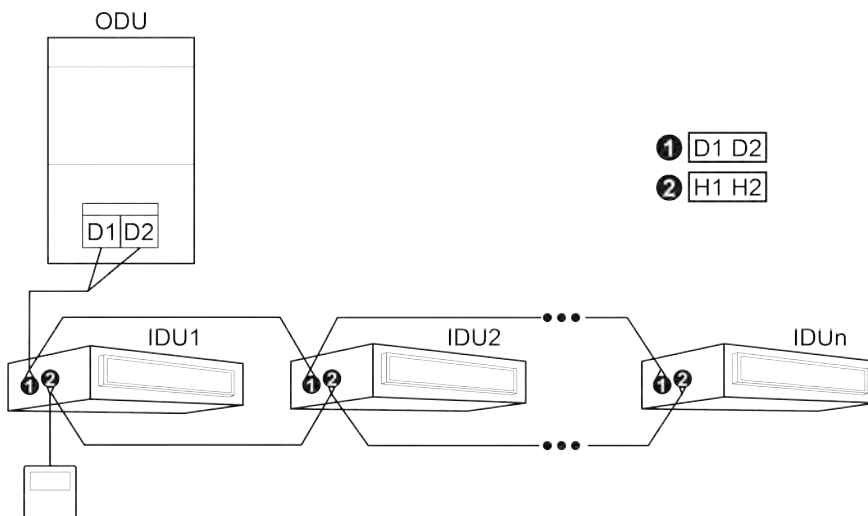

Fig. 3.9.11 One wired controller control multiple IDU

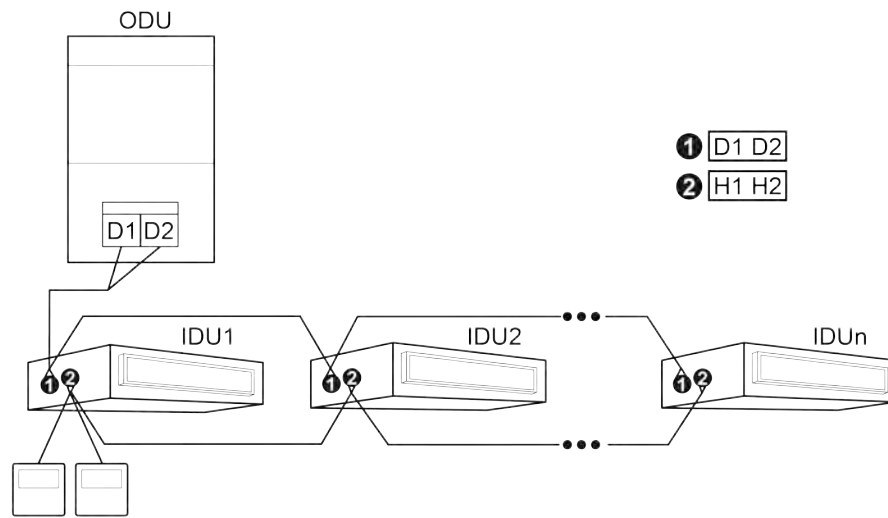

Fig. 3.9.12 Two wired controllers control multiple IDU

When two wired controllers control multiple IDUs, the wired controller can be connected to any one IDU, provided that the connected IDU is of the same series. Meanwhile, one and only one of the wired controllers must be set as a slave controller. At most 16 IDUs can be controlled by wired controllers and the connected IDUs shall be within a same IDU network.

No matter when unit is turned on or off, slave controller can be set.

How to set a slave controller: hold “function” button on the designated controller for 5s, and temperature zone displays C00. Continue holding “function” button for 5s and setting screen of controller parameter will come out. Default temperature zone displays P00.

Press ▲ button or ▼ button to select parameter code P13. Press “mode” button to switch to setup of parameter values. Then the parameter value will blink. Press ▲ button or button ▼ to select code 02. And then press “confirm/cancel” to finish setting.

Press “confirm/cancel” to return to the previous display until you exit from the setup of parameter values.

Below are user's parameter settings:

Parameter code	Parameter name	Parameter scope	Default value	Remark
P13	Set up address for wired controller	01: master wired controller 02: slave wired controller	01	When 2 wired controllers control one or more IDUs, they shall have different addresses. Slave wired controller (02) can't set up units' parameters except its address.

3.9.7 Other Communication Connection Methods

For the communication connection among indoor units, between ducted type indoor unit and the receiving light board, please refer to the indoor unit manual.

3.10 Check Items after Installation

Check Items	Conditions Might Happen	Check
Has the unit been fixed firmly?	The unit may drop, shake or emit noise.	
Have you done the gas leakage test?	It may cause insufficient cooling/heating capacity.	
Dose the unit get proper thermal insulation?	It may cause condensation and dripping.	

Check Items	Conditions Might Happen	Check
Does the unit drain well?	It may cause condensation and dripping.	
Is the voltage in accordance with the rated voltage specified on the nameplate?	It may cause malfunction or damage the part.	
Is the electric wiring and pipe connection installed correctly and securely?	It may cause malfunction or damage the part.	
Has the unit been earthed securely?	It may cause electrical leakage.	
Is the power cord specified?	It may cause malfunction or damage the part.	
Has the inlet and outlet been blocked?	It may cause insufficient cooling/heating capacity.	
Has the pipe length and refrigerant charging amount been recorded?	The refrigerant charging amount is not accurate.	
Is the address code of outdoor modules correct?	The unit can't run normally. Communication malfunction might happen.	
Is the address code of indoor units and wired controller correct?	The unit can't run normally. Communication malfunction might happen.	
Has the communication line been connected correctly?	The unit can't run normally. Communication malfunction might happen.	
Is the pipe connection and valve status right?	The unit can't run normally.	
Whether phase sequence of external power cord is correct or not?	Operation fault occurs or unit is damaged.	

The above inspection items after installation are the inspection for some key components.

Please conduct the check according to actual needs.

4 Debugging and Operation



NOTES!

- (1) Do set one (only one) module as the main module during debugging.
- (2) When there is no special requirement, the other functions do not need to be set, and it can be operated according to the factory settings. For special functions, please refer to the related technical documents.
- (3) Button description: short press: press the button for 3s and then release it; hold the button for 5s: press the button for 5-10s and then release it; hold the button for 10s: press the button for 10s and then release it.

4.1 Preparation before Test Run

- (1) Installation and debugging operation must comply with the relevant regulations of the local country or region.
- (2) Debugging must be carried out by a professional or under the guidance of a professional. Do not debug the air conditioning unit by yourself.
- (3) All scattered objects, especially metal chips, wire ends and clamps, should be removed from the body.
- (4) Check if the terminals of the electrical components in the unit are loose and the phase sequence is correct.
- (5) Before debugging, all pipeline valves of the unit are required to be open.
- (6) Power cannot be supplied until all installation work is completed.

4.2 Notices for Unit Debugging

- (1) Before conducting the debugging, please ensure that the compressor has been preheated for more than 2 hours, and check whether the preheating is normal by hand. Debugging can be started up only when the preheating is normal, otherwise the compressor may be damaged.

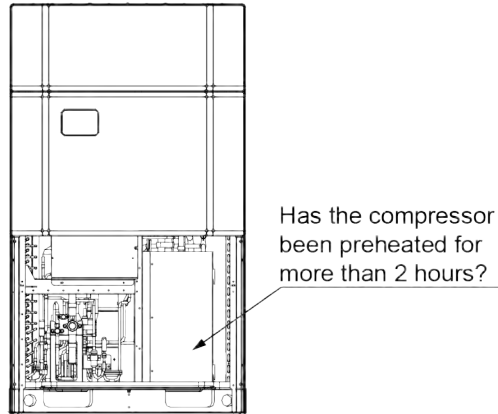

Fig. 4.2.1

- (2) When starting up the debugging, the system automatically selects the operating mode according to the current ambient temperature.
- (3) When debugging, the front panel of the outdoor unit must be completely closed, otherwise it will affect the accuracy of debugging (as shown in the Fig. as below).

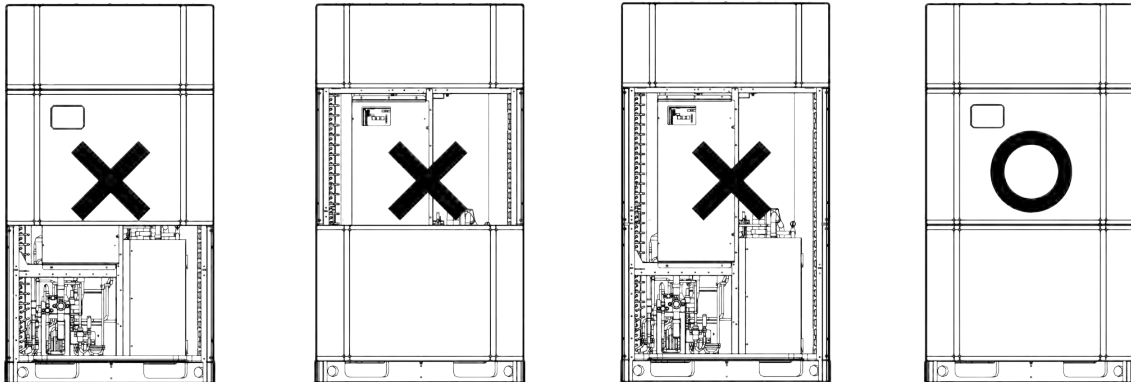

Fig. 4.2.2

(4) Display instruction for each stage progress at the time of debugging:

Instruction for each stage progress at the time of debugging							
—	Debugging code		Progress code		Status code		Meaning
Progress	LED1		LED2		LED3		
	Code	Display status	Code	Display status	Code	Display status	
01_set up master unit	db	ON	01	ON	A0	ON	Undebugged status.
	db	ON	01	ON	CC	ON	The system hasn't set master module. It needs to reset it.
	db	ON	01	ON	CF	ON	The system has set more than 2 master modules. It needs to reset it.
	db	ON	01	ON	OC	ON	Master module setting is succeeded. It will automatically enter into the next step.
02_allocate addresses	db	ON	02	ON	Ad	Flash	The system is conducting the address assignment.
	db	ON	02	ON	OC	ON	Address assignment is succeeded. It will automatically enter into the next step.
03_module quantity confirmation	db	ON	03	ON	01~04	Flash	LED3 displays the module quantity. It needs to manually confirm the module quantity.
	db	ON	03	ON	OC	ON	Once the system module quantity is confirmed, it will automatically enter into the next step for judgment.
04_indoor unit quantity confirmation	db	ON	04	ON	××/ The quantity of online indoor units	Flash	LED3 displays the quantity of online indoor units.
	db	ON	04	ON	OC	ON	Indoor unit's quantity inspection is finished. Enter into the next step automatically.
05_detect internal communication	db	ON	05	ON	C2	ON	The system has detected "communication malfunction between main control and inverter compressor driver".
	db	ON	05	ON	C3	ON	The system has detected "communication malfunction between main control and inverter fan driver".
	db	ON	05	ON	CH	ON	Indoor/outdoor unit's "rated capacity ratio is too high".
	db	ON	05	ON	CL	ON	Indoor/outdoor unit's "rated capacity ratio is too low".
	db	ON	05	ON	OC	ON	System inspection is finished. Enter into the next step automatically.
06_outdoor unit components inspection	db	ON	06	ON	corresponding error code	ON	The system has detected the fault of outdoor unit' components.
	db	ON	06	ON	OC	ON	The system detected that there's no outdoor unit fault. Enter into the next step automatically.
07_indoor unit components inspection	db	ON	07	ON	XXXX/corresponding error code	ON	The system detected an indoor unit fault. XXXX indicates engineering number of fault indoor unit, and the corresponding fault code is displayed 2s later. For example, if there is D5 fault in the No. 100 indoor unit, LED3 displays as follows: 01 (after 2s) 00 (after 2s) d5, and they will be displayed circularly.
	db	ON	07	ON	OC	ON	The system detected that there's no outdoor unit fault. Enter into the next step automatically.

DC Inverter Multi VRF System

Instruction for each stage progress at the time of debugging							
—	Debugging code		Progress code		Status code		Meaning
Progress	LED1		LED2		LED3		
	Code	Display status	Code	Display status	Code	Display status	
08_compress or preheat confirmation	db	ON	08	ON	U0	ON	Preheat time for compressor is insufficient.
	db	ON	08	ON	OC	ON	Preheat time for compressor is enough. Enter into the next step automatically.
09_refrigerant judge before start up	db	ON	09	ON	U4	ON	The system refrigerant is insufficient. Please charge the refrigerant until the fault is eliminated.
	db	ON	09	ON	OC	ON	The system refrigerant judge is normal. Enter into the next step automatically.
10_status judgment of main pipeline before starting	db	ON	10	ON	ON	ON	Starting up the operation.
	db	ON	10	ON	U6	ON	Main pipeline status is abnormal.
	db	ON	10	ON	OC	ON	Main pipeline status is normal.
11_reserved function	db	ON	11	ON	AE	ON	—
12_reserved function	db	ON	12	ON	01	ON	—
13~15_pilot run stage	db	ON	13/14/15	ON	AC	ON	Test run under heating mode.
	db	ON	13/14/15	ON	AH	ON	Test run under cooling mode.
	db	ON	13/14/15	ON	Corresponding error code	ON	There is fault in the pilot run stage. Note: fault module display.
	db	ON	13/14/15	ON	J0	ON	There is fault in the pilot run stage. Note: non-fault module display.
	db	ON	13/14/15	ON	XXXX/U8	ON	The system detected the indoor unit's pipeline is abnormal. XXXX indicates the engineering number of fault indoor unit. Error code U8 is displayed after 2s. For example, if the U8 fault occurs in the No. 100 indoor unit, LED3 displays as follows: 01 (after 2s) 00 (after 2s) U8, and they will be displayed circularly.

Note: In the pilot run stage, the unit will display corresponding procedures according to actual circumstances.

When master module displays as below, the complete unit has conducted the debugging and it stays at the standby status.

Debugging code		Progress code		Status code		Meaning
LED1		LED2		LED3		
Code	Display status	Code	Display status	Code	Display status	
01~04	ON	OF	ON	OF	ON	The complete unit has conducted the debugging and the unit is under standby status. LED1 displays module address; LED2 and LED3 displays "OF".

4.3 Basic Introduction for Engineering Debugging

4.3.1 Debugging Method

DC inverter multi VRF unit has three debugging methods at present:

- (1) Conduct it by pressing the buttons on the main board of outdoor unit.
- (2) Install proprietary software to conduct the debugging through PC. Indoor and outdoor units' parameters displayed simultaneously through PC software.
- (3) Use multi-functional debugger.

Note: As for the detailed operation method for debugging, please refer to corresponding instruction manual.

4.3.2 Debugging Through the Main Board of Outdoor Unit

When conducting the debugging through the main board of outdoor unit, the main board has the following debugging operation functions.

Step 1: Cover all the front panels of the outdoor unit and open the debugging window of each basic module.

Step 2: When the outdoor unit is powered off, set one of the modules as the master module. For the setting method, see "Master Module DIP Switch Code Setting (SA8_MASTER-S)".

Step 3: Under the power-on state of the outdoor unit, set the corresponding static pressure module for the unit according to the design requirements of the outdoor static pressure of the project.

Step 4: The module address is displayed as "01" is the master module. On the master module, press and hold the SW3 confirmation button for 5 seconds or press the SW3 confirmation button for more than 10 seconds to enter the unit debugging function.

Step 5: Wait. The unit automatically runs the steps 01 and 02 at this time.

If the master module is set incorrectly in step 01, the following corresponding fault is displayed in step 01:

Progress	Debugging code		Progress code		Status code		Meaning
	LED1		LED2		LED3		
	Code	Display status	Code	Display status	Code	Display status	
01_ set up master unit	db	ON	01	ON	CC	ON	Master module hasn't been set in the system. It needs to reset it.
	db	ON	01	ON	CF	ON	More than two master modules are set in the system and it needs to reset it.
	db	ON	01	ON	OC	ON	Master module of system has been set successfully. Enter into the next step automatically.

According to the above fault phenomenon, reset the master module according to the setting method of "Master Module DIP Switch Code Setting (SA8_MASTER-S)", and re-enter into the debugging after setting.

During the assignment process, all module digital tubes displays are as below:

Progress	Debugging code		Progress code		Status code	
	LED1		LED2		LED3	
	Code	Display status	Code	Display status	Code	Display status
02_ allocate addresses	db	ON	02	ON	Ad	Flash

Step 6: When the unit is running to step 03, it displays the number of modules connected to the outdoor connection. At this time, the main board of each module is displayed as below:

—	Debugging code		Progress code		Status code	
Progress	LED1		LED2		LED3	
	Code	Display status	Code	Display status	Code	Display status
03_module quantity confirmation	db	ON	03	ON	Module quantity	Flash

After 30s of display, the automatic display is as follows; if press SW3 button within 30s, the display is as follows. The unit automatically enters the next step of debugging:

—	Debugging code		Progress code		Status code	
Progress	LED1		LED2		LED3	
	Code	Display status	Code	Display status	Code	Display status
03_module quantity confirmation	db	ON	03	ON	OC	ON

Note: It is important to confirm that the number of online outdoor unit modules is the same as that of actual modules; otherwise it will need to conduct the inspection and debugging again.

Step 7: When the unit is running to step 04, the number of online connected indoor unit is displayed. At this time, the main board of each module is displayed as below:

—	Debugging code		Progress code		Status code	
Progress	LED1		LED2		LED3	
	Code	Display status	Code	Display status	Code	Display status
04_indoor unit quantity confirmation	db	ON	04	ON	The quantity of online indoor units	Flash

After 30s of display, the display is as follows; if press SW3 button within 30s, the display is as follows. The unit automatically enters the next step of debugging:

—	Debugging code		Progress code		Status code	
Progress	LED1		LED2		LED3	
	Code	Display status	Code	Display status	Code	Display status
04_indoor unit quantity confirmation	db	ON	04	ON	OC	ON

Note: It is important to confirm that the number of online indoor unit modules is the same as that of actual connected indoor units for the project; otherwise it will need to conduct the inspection and debugging again.

Step 8: Step 05 of the unit debugging is “detect internal communication”.

If there is no abnormality in the detection, the display is below, and then it automatically enters the next step of detection.

—	Debugging code		Progress code		Status code		Meaning
Progress	LED1		LED2		LED3		
	Code	Display status	Code	Display status	Code	Display status	
05_detect internal communication	db	ON	05	ON	OC	ON	Once the system inspection is completed, it will enter into the next step automatically.

If an abnormality is detected, it will stay in the current state and manual troubleshooting is required. The corresponding faults are as below:

—	Debugging code		Progress code		Status code		Meaning
Progress	LED1		LED2		LED3		
	Code	Display status	Code	Display status	Code	Display status	
05_detect internal communication	db	ON	05	ON	C2	ON	The system has detected "communication malfunction between main control and inverter compressor driver".
	db	ON	05	ON	C3	ON	The system has detected "communication malfunction between main control and inverter fan driver".
	db	ON	05	ON	CH	ON	Indoor/outdoor units' rated capacity ratio is too high.
	db	ON	05	ON	CL	ON	Indoor/outdoor units' rated capacity ratio is too low.

Refer to the part of "Troubleshooting" for the corresponding troubleshooting method.

Step 9: The unit debugging step 06 is "outdoor unit's components inspection".

If there is no abnormality in the detection, the display is below, and then it automatically enters the next step of detection.

—	Debugging code		Progress code		Status code		Meaning
Progress	LED1		LED2		LED3		
	Code	Display status	Code	Display status	Code	Display status	
06_outdoor unit's components inspection	db	ON	06	ON	OC	ON	The system detected that there's no fault for outdoor unit's parts. Then it will automatically enter into the next step.

If an abnormality is detected, it will stay in the current state and manual troubleshooting is required. The corresponding faults are as below:

—	Debugging code		Progress code		Status code		Meaning
Progress	LED1		LED2		LED3		
	Code	Display status	Code	Display status	Code	Display status	
06_outdoor unit's components inspection	db	ON	06	ON	Corresponding error code	ON	The system detected that there's fault for outdoor unit's parts.

Refer to the part of "Troubleshooting" for the corresponding troubleshooting method.

Step 10: The unit debugging step 07 is "indoor unit's components inspection".

If there is no abnormality in the detection, the display is as below, and then it automatically enters the next step of detection.

DC Inverter Multi VRF System

—	Debugging code		Progress code		Status code		Meaning
Progress	LED1		LED2		LED3		
	Code	Display status	Code	Display status	Code	Display status	
07_indoor unit's components inspection	db	ON	07	ON	OC	ON	The system detected that there's no fault for indoor unit's parts. Then it will automatically enter into the next step.

If an abnormality is detected, it will stay in the current state and manual troubleshooting is required. The corresponding faults are as below:

—	Debugging code		Progress code		Status code		Meaning
Progress	LED1		LED2		LED3		
	Display status	Code	Display status	Code	Display status	Display status	
07_indoor unit's components inspection	db	ON	07	ON	XXXX/ corresponding error code	ON	The system detected that there's fault for indoor unit's parts.

XXXX indicates the engineering no. of fault indoor unit. 3s later, the corresponding error code will be displayed. For example, if d5 fault occurs for No.100 indoor unit, LED3 displays as below: 01 (2s later) 00(2s later) d5, and they will display like that circularly.

Refer to the part of "Troubleshooting" for the corresponding troubleshooting method.

Step 11: The debugging step 08 is "compressor preheat confirmation".

If the preheat time has reached for 2h, the display is as below. Then it will enter into the next step for inspection.

—	Debugging code		Progress code		Status code		Meaning
Progress	LED1		LED2		LED3		
	Code	Display status	Code	Display status	Code	Display status	
08_compressor preheat confirmation	db	ON	08	ON	OC	ON	Compressor's preheat time has reached 2h, and then it will enter into the next step.

If the preheat time for compressor hasn't reached 2h, there will be abnormal phenomenon. The display is as below.

—	Debugging code		Progress code		Status code		Meaning
Progress	LED1		LED2		LED3		
	Code	Display status	Code	Display status	Code	Display status	
08_compressor preheat confirmation	db	ON	08	ON	U0	ON	The preheat time for compressor hasn't reached 2h.

Step 12: Unit debugging step 09 is "refrigerant judgment before start up".

If the amount of refrigerant inside the system satisfies the requirements for starting the operation, the display is as below. Then it will automatically enter into the next step.

—	Debugging code		Progress code		Status code		Meaning
Progress	LED1		LED2		LED3		
	Code	Display status	Code	Display status	Code	Display status	
09_refrigerant judge before start up	db	ON	09	ON	OC	ON	The system refrigerant judgment is normal. It will automatically enter into the next step.

If there is no refrigerant in the system or the amount of refrigerant does not meet the requirements for starting operation, the unit will display U4 “Refrigerant-lacking protection”, as shown below. The unit will enter into the next step. At this time, it is necessary to check whether there is a leak or charge some refrigerant until the abnormality is eliminated.

—	Debugging code		Progress code		Status code		Meaning
Progress	LED1		LED2		LED3		
	Code	Display status	Code	Display status	Code	Display status	
09_refrigerant judge before start up	db	ON	09	ON	U4	ON	The refrigerant in the system is insufficient. Please charge refrigerant until the fault disappears.

Step 13: Unit debugging step 10 is “status judgment of main pipeline before starting”.

If the main module displays as below, it indicates the unit is starting the operation for judgment.

—	Debugging code		Progress code		Status code		Meaning
Progress	LED1		LED2		LED3		
	Code	Display status	Code	Display status	Code	Display status	
10_status judgment of main pipeline before starting	db	ON	10	ON	ON	ON	Starting and operating

If the unit has detected the abnormal status, the display is as below:

—	Debugging code		Progress code		Status code		Meaning
Progress	LED1		LED2		LED3		
	Code	Display status	Code	Display status	Code	Display status	
10_status judgment of main pipeline before starting	db	ON	10	ON	U6	ON	Main pipeline is abnormal

At this time, it is necessary to check whether the gas valve and the liquid valve are completely open or whether the main pipeline is blocked. Once inspection is completed, you can return to the previous step by pressing SW4 button to re-enter the judgment.

If inspection valve of the unit is normal, the display is as below. The unit will automatically enter into the next step.

—	Debugging code		Progress code		Status code		Meaning
Progress	LED1		LED2		LED3		
	Code	Display status	Code	Display status	Code	Display status	
10_status judgment of main pipeline before starting	db	ON	10	ON	OC	ON	The main pipeline is turned on normally

Step 14: Unit debugging step 11 is “reserved function”.

The main module display is as below. The unit automatically enters into the next step.

—	Debugging code		Progress code		Status code		Meaning
Progress	LED1		LED2		LED3		
	Code	Display status	Code	Display status	Code	Display status	
11_reserved function	db	ON	11	ON	AE	ON	—

Step 15: Unit debugging step 12 is “reserved function”.

The master module display is as below. Then the unit automatically enters into the next step.

DC Inverter Multi VRF System

—	Debugging code		Progress code		Status code		Meaning
Progress	LED1		LED2		LED3		
	Code	Display status	Code	Display status	Code	Display status	
12_reserved function	db	ON	12	ON	01	ON	—

Step 16: After the unit debugging method is confirmed, the system automatically selects cooling or heating mode according to the ambient temperature.

Once cooling/heating mode is selected, the relevant display is as below.

—	Debugging code		Progress code		Status code		Meaning
Progress	LED1	LED2	LED3	LED1	LED2	LED3	
	Code	Display status	Code	Display status	Code	Display status	
13~15_pilot run stage	db	ON	13/14/ 15	ON	AC	ON	Pilot run of cooling mode
	db	ON	13/14/ 15	ON	AH	ON	Pilot run of heating mode
	db	ON	13/14/ 15	ON	Corresponding error code	ON	There's fault on pilot run stage. Note: fault module display
	db	ON	13/14/ 15	ON	J0	ON	There's fault on pilot run stage. Note: non-fault module display
	db	ON	13/14/ 15	ON	U9	ON	Outdoor unit's pipeline or valve is abnormal.
	db	ON	13/14/ 15	ON	XXXX/ U8	ON	The system detected the indoor unit's pipeline is abnormal. XXXX indicates engineering number of fault indoor unit. 2s later, U8 fault occurred for No. 100 indoor unit. LED3 will display as below: 01 (2s later) 00 (2s later) U8, and it will display like that circularly.

Note: In the pilot run stage, the unit will display corresponding procedures according to actual circumstances.

Once debugging is completed, resume the standby status and the display is as below:

Debugging code		Progress code		Status code		Meaning
LED1		LED2		LED3		
Code	Display status	Code	Display status	Code	Display status	
01~04	ON	OF	ON	OF	ON	The complete unit has finished the debugging and it stays at standby status. LED1 displays module address; LED2 and LED3 displays "OF".

Once the debugging for the complete unit is finished, please set relevant functions for the unit according to the actual functional requirements of the project. Refer to relative technical materials for the detailed operation method. If there is no special requirement, skip this step directly.

When delivery it to the user for operation, explain the precautions to the user.

4.4 Parameter Judgment Reference Value for Unit Normal Operation

Debugging Parameter Reference Value for DC Inverter VRF Unit						
No.	Debugging item		Parameter name	Unit	Reference value	Remark
1	System parameter	Outdoor unit's parameter	Outdoor ambient temperature	°C	—	—
2			Discharge pipe temperature of inverter compressor 1	°C	<ul style="list-style-type: none"> When the compressor starts running, the normal discharge pipe of cooling or shell top temperature is 70~95°C, above 10°C higher than the saturation temperature of system high pressure; the normal heating temperature is 65~90 °C, above 10°C higher than the saturation temperature of system high pressure. 	—
3			Shell top tube temperature of inverter compressor 1	°C		—
4			Discharge pipe temperature of inverter compressor 2	°C		—
5			Shell top tube temperature of inverter compressor 2	°C		—
6			Temperature of defrosting temperature sensor	°C		<ul style="list-style-type: none"> When the system is running in cooling mode, the temperature of defrosting temperature sensor is 5~11°C lower than system high pressure; When the system is running in heating mode, the temperature difference between the defrosting temperature sensor and the system low pressure is about 2°C.
7			System high pressure	°C	<ul style="list-style-type: none"> The normal high pressure value of the system is 20°C~55°C. According to the change of ambient temperature and the change of operating capacity of the system, the high pressure value of the system is 10°C~40°C higher than the ambient temperature. The higher the ambient temperature, the smaller the temperature difference; When the unit operating in the cooling mode at the ambient temperature of 25~35°C, the system high pressure value is 44~56°C; When the unit operating in the heating mode at the ambient temperature of -5~10°C, the system high pressure value is 40~56°C; 	—
8			System low pressure	°C	<ul style="list-style-type: none"> When the unit operating in the cooling mode at the ambient temperature of 25~35°C, the system low pressure value is 0~8°C; When the unit operating in the heating mode at the ambient temperature of -5~10°C, the system low pressure value is -15~5°C; 	—
9			Opening of electronic expansion valve of heating	PLS	<ul style="list-style-type: none"> During cooling operation, the electronic expansion valve of heating is 3000PLS; During heating operation, the adjustable range of the opening of electric expansion valve opening is 720~3000PLS. 	—
10			Operation frequency of inverter compressor	Hz	<ul style="list-style-type: none"> Change among 20Hz~140Hz 	—

Debugging Parameter Reference Value for DC Inverter VRF Unit						
No.	Debugging item	Parameter name	Unit	Reference value	Remark	
11	System parameter	Outdoor unit's parameter	IPM module temperature of inverter compressor	°C	<ul style="list-style-type: none"> IPM module temperature is lower than 80°C. The highest temperature doesn't exceed 95°C. 	—
12			Drive bus voltage of inverter compressor	V	<ul style="list-style-type: none"> The normal bus voltage is 1.414 times of the power supply voltage. For example, if the three-phase power supply voltage is 390V, then the rectified bus voltage is: $390V \times 1.414 = 551V$. The normal deviation between the measured value and the calculated value within 15V. 	—
13			Fan operation frequency	Hz	<ul style="list-style-type: none"> Adjust the operation in the range of 0~90Hz according to the system pressure adjustment. 	—
14		Indoor unit's parameter	Inlet tube temperature of indoor heat exchanger	°C	<ul style="list-style-type: none"> According to the ambient temperature, the inlet temperature is 1°C~7°C lower than the outlet temperature for the same indoor unit under cooling mode. 	—
15			Outlet tube temperature of indoor heat exchanger	°C	<ul style="list-style-type: none"> The inlet temperature is 10°C ~20°C lower than the outlet temperature for the same indoor unit under the heating mode. 	—
16			Opening of indoor electronic expansion valve	PLS	<ul style="list-style-type: none"> 2000PLS electronic expansion valve: the opening is adjusted automatically in the range of 200~2000PLS; 480PLS electronic expansion valve: the opening is adjusted automatically in the range of 70~480PLS. 	—
17	Drainage system	—	—	<ul style="list-style-type: none"> The indoor unit drains smoothly and thoroughly, and the condensate water pipe has no slope water storage; the outdoor unit can drain water from the drain pipe without dripping directly from the unit foundation. 	—	
18	Other	—	—	<ul style="list-style-type: none"> There is no abnormal noise for the operation of the compressor, indoor fan and outdoor fan. The unit is running normally. 	—	

5 Operation Instruction

For instructions on how to use the air conditioner, please refer to the user manual of wired controller or remote controller.

6 Maintenance

Regular inspection and maintenance can extend the service life of the air conditioning unit.

6.1 Heat Exchanger of Outdoor Unit

The heat exchanger of outdoor unit should be cleaned regularly. A vacuum cleaner can be used with a nylon brush to clean dust and debris from the surface of the heat exchanger. If there is compressed air source, the compressed air can be used to blow dust from the surface of the heat exchanger. Do not wash it with tap water.

6.2 Drain Pipe

The drain pipe should be checked regularly to allow the condensate to drain smoothly.

6.3 Precautions at the Beginning of Using Season

- (1) Check whether all air inlet and air outlet of indoor unit and outdoor unit are not blocked.
- (2) Check if the grounding is reliable.
- (3) Check if the battery of the remote controller has been replaced.
- (4) Check if the air filter is properly installed.
- (5) When restart up the unit after it has been stop operation for a long time, turn on the air conditioner's power switch 2 hours before starting the operation to preheat the outdoor compressor crankcase.
- (6) Check if the outdoor unit is installed firmly. If there is any abnormality, please contact ASAMI service center.

6.4 Maintenance at the End of Using Season

- (1) Cut off the main power of the air conditioning unit.
- (2) Clean the filter and indoor and outdoor units' body.
- (3) Remove dust and debris from indoor and outdoor units.
- (4) If the outdoor unit is rusted, smear the oil paint to prevent it from expansion.

6.5 Parts Replacement

Accessories are available through the nearby ASAMI office or ASAMI dealer.



NOTE!

Do not mix dangerous gases such as oxygen and acetylene into the refrigeration circuit during air tightness and leak test! To avoid danger, it is best to use nitrogen for such tests.

7 Troubleshooting

7.1 Common Malfunction and Troubleshooting

Check the following items before asking for repair.

Phenomenon	Reason	Measure
The unit doesn't run.	Without power supply	Connect to power supply
	Voltage is too low	Check if the voltage is within rating range
	Broken fuse or breaker trips off	Replace fuse or connect breaker
	Insufficient energy of remote controller	Replace new battery
	Remote controller is out of control scope	Control scope is within 8m
Unit runs but stop immediately	Air intake or outlet of indoor or outdoor unit is blocked	Remove obstruction
Abnormal cooling or heating	Air intake or outlet of indoor or outdoor unit is blocked	Remove obstruction
	Improper temperature setting	Adjust setting at wireless remote controller or wired controller
	Fan speed is set too low	Adjust setting at wireless remote controller or wired controller
	Wind direction is not correct	Adjust setting at wireless remote controller or wired controller

DC Inverter Multi VRF System

Phenomenon	Reason	Measure
Abnormal cooling or heating	Door or windows are opened	Close the door or windows
	Direct sunshine	Draw curtain or louver
	Too many people in the room	—
	Too many heat resources in the room	Reduce heat resources
	Filter is blocked for dirt	Clean the filter



NOTE!

If problem cannot be solved after checking the above items, please contact ASAMI service center and show phenomena and models.

Following circumstances are not malfunction.

“Malfunction”		Reason
Unit doesn't run	When unit is started immediately after it is just turned off	Overload protection switch makes it run after 3 minutes delay
	When power is turned on	Standby operating for about 1 minute
Mist comes from the unit	Under cooling	Indoor high humidity air is cooled rapidly
Noise is emitted	Slight cracking sound is heard when just turned on	It is noise when electronic expansion valve initialization
	There is consecutive sound when cooling	That's sound for gas refrigerant flowing in unit
	There is sound when unit starts or stops	That's sound for gas refrigerant stops to flow
	There is slight and consecutive sound when unit is running or after running	That's sound for operation of drainage system
	Cracking sound is heard when unit is operating and after operating	That's sound caused by expansion of panel and other parts due to temperature change
The unit blows out duct	When unit runs after no operation for a long period	Dust in indoor unit is blew out
The unit emits odor	Operating	The room odor absorbed by the unit is blew out again
Indoor unit still runs after switch off	After every indoor unit receive "stop" signal, fan will keep running	Indoor fan motor will keep running 20-70s so as to take good use of excess cooling and heating and prepare for next operation
Mode conflict	COOL or HEAT mode can't be operated	When the indoor operating mode conflicts with that of outdoor unit, indoor fault indicator will flash and conflict will be shown on the wired controller after 5 minutes. Indoor unit stops to run and meanwhile change outdoor operating mode as the same as that of indoor unit, then the unit will go back to normal. COOL mode doesn't conflict with DRY mode. FAN mode doesn't conflict with any mode.

7.2 Error Indication



NOTE!

For specific unit fault and maintenance, please refer to the engineering debugging and after-sales maintenance manual of DC inverter VRF unit.

—	Error Code	Content	Error Code	Content
Indoor	L0	Malfunction of IDU	L1	Protection of indoor fan
	L2	Auxiliary heating protection	L3	Water-full protection
	L4	Abnormal power supply for wired controller	L5	Freeze prevention protection
	L6	Mode conflict	L7	No main IDU
	L8	Power supply is insufficient	L9	For single control over multiple units, number of IDU is inconsistent (HBS network)
	LA	For single control over multiple units, IDU series is inconsistent (HBS network)	LH	Alarm due to bad air quality
	LC	IDU is not matching with outdoor unit	LL	Malfunction of water flow switch
	LE	Rotation speed of EC DC water pump is abnormal	LF	Malfunction of shunt valve setting
	LJ	Setting of functional DIP switch code is wrong	LP	Zero-crossing malfunction of PG motor
	LU	Indoor unit's branch is not inconsistent for one-to-more unit of heat recovery system	Lb	For single control over multiple units, IDU is inconsistent (reheating-dehumidifying system)
	d1	Indoor PCB is poor	d2	Malfunction of lower water temperature sensor of water tank
	d3	Malfunction of ambient temperature sensor	d4	Malfunction of entry-tube temperature sensor
	d5	Malfunction of mid-tube temperature sensor	d6	Malfunction of exit-tube temperature sensor
	d7	Malfunction of humidity sensor	d8	Malfunction of water temperature sensor
	d9	Malfunction of jumper cap	dA	Web address of IDU is abnormal
	dH	PCB of wired controller is abnormal	dC	Setting capacity of DIP switch code is abnormal
	dL	Malfunction of air outlet temperature sensor	dE	Malfunction of indoor CO ₂ sensor
	dF	Malfunction of upper water temperature sensor of water tank	dJ	Malfunction of backwater temperature sensor
	dP	Malfunction of inlet tube temperature sensor of generator	dU	Malfunction of drainage pipe temperature sensor of generator
	db	Debugging status	dd	Malfunction of solar power temperature sensor
	dn	Malfunction of swing parts	dy	Malfunction of water temperature sensor
	y1	Malfunction of entry-tube temperature sensor 2	y2	Malfunction of exit-tube temperature sensor 2
	y7	Malfunction of fresh air inlet temperature sensor	y8	Malfunction of IDU's air box sensor
	yA	Malfunction of IFD	o1	Low-voltage protection of IDU's bus bar
	o2	High-voltage protection of IDU's bus bar	o3	IPM module protection of IDU
	o4	Failure startup of IDU	o5	Over-current protection of IDU

DC Inverter Multi VRF System

—	Error Code	Content	Error Code	Content
Indoor	o6	Malfunction of current detection circuit of IDU	o7	Desynchronizing protection of IDU
	o8	Communication malfunction of IDU's driver	o9	Communication malfunction of IDU's main control
	oA	Drive IPM high temperature protection of IDU	ob	Malfunction of drive temperature sensor of IDU
	oC	Malfunction of charging loop of IDU	o0	Other malfunction of drive
Outdoor	E0	Malfunction of ODU	E1	High-pressure protection
	E2	Discharge low-temperature protection	E3	Low-pressure protection
	E4	High discharge temperature protection of compressor	Ed	Drive IPM low temperature protection
	F0	Main board of ODU is poor	F1	Malfunction of high-pressure sensor
	F3	Malfunction of low-pressure sensor	F5	Malfunction of discharge temperature sensor of compressor 1
	F6	Malfunction of discharge temperature sensor of compressor 2	F7	Malfunction of discharge temperature sensor of compressor 3
	F8	Malfunction of discharge temperature sensor of compressor 4	F9	Malfunction of discharge temperature sensor of compressor 5
	FA	Malfunction of discharge temperature sensor of compressor 6	FC	Current sensor of compressor 2 is abnormal
	FL	Current sensor of compressor 3 is abnormal	FE	Current sensor of compressor 4 is abnormal
	FF	Current sensor of compressor 5 is abnormal	FJ	Current sensor of compressor 6 is abnormal
	FP	Malfunction of DC motor	FU	Malfunction of casing top temperature sensor of compressor 1
	Fb	Malfunction of casing top temperature sensor of compressor 2	Fd	Malfunction of exit tube temperature sensor of mode exchanger
	Fn	Malfunction of inlet tube temperature sensor of mode exchanger	J0	Protection for other modules
	J1	Over-current protection of compressor 1	J2	Over-current protection of compressor 2
	J3	Over-current protection of compressor 3	J4	Over-current protection of compressor 4
	J5	Over-current protection of compressor 5	J6	Over-current protection of compressor 6
	J7	Gas-mixing protection of 4-way valve	J8	High pressure ratio protection of system
	J9	Low pressure ratio protection of system	JA	Protection because of abnormal pressure
	JC	Water flow switch protection	JL	Protection because high pressure is too low
	JE	Oil-return pipe is blocked	JF	Oil-return pipe is leaking
	b1	Malfunction of outdoor ambient temperature sensor	b2	Malfunction of defrosting temperature sensor 1
	b3	Malfunction of defrosting temperature sensor 2	b4	Malfunction of liquid outlet temperature sensor of sub-cooler
	b5	Malfunction of gas outlet temperature sensor of sub-cooler	b6	Malfunction of inlet tube temperature sensor of vapor liquid separator
	b7	Malfunction of exit tube temperature sensor of vapor liquid separator	b8	Malfunction of outdoor humidity sensor
	b9	Malfunction of gas temperature sensor of heat exchanger	bA	Malfunction of oil-return temperature sensor 1
	bH	Clock of system is abnormal	bE	Malfunction of inlet tube temperature sensor of condenser
	bF	Malfunction of outlet tube temperature sensor of condenser	bJ	High-pressure sensor and low-pressure sensor are connected reversely

—	Error Code	Content	Error Code	Content
Outdoor	bP	Malfunction of temperature sensor of oil-return 2	bU	Malfunction of temperature sensor of oil return 3
	bb	Malfunction of temperature sensor of oil return 4	bd	Malfunction of gas inlet temperature sensor of sub-cooler
	bn	Malfunction of liquid inlet temperature sensor of sub-cooler	P0	Malfunction of driving board of compressor
	P1	Driving board of compressor operates abnormally	P2	Voltage protection of driving board power of compressor
	P3	Reset protection of driving module of compressor	P4	Drive PFC protection of compressor
	P5	Over-current protection of inverter compressor	P6	Drive IPM module protection of compressor
	P7	Malfunction of drive temperature sensor of compressor	P8	Drive IPM high temperature protection of compressor
	P9	Desynchronizing protection of inverter compressor	PA	Malfunction of drive storage chip of compressor
	PH	High-voltage protection of compressor's drive DC bus bar	PC	Malfunction of current detection circuit drive of compressor
	PL	Low voltage protection for DC bus bar of drive of compressor	PE	Phase-lacking of inverter compressor
	PF	Malfunction of charging loop of driven of compressor	PJ	Failure startup of inverter compressor
	PP	AC current protection of inverter compressor	PU	AC input voltage of drive of inverter compressor
	H0	Malfunction of driving board of fan	H1	Driving board of fan operates abnormally
	H2	Voltage protection of driving board power of fan	H3	Reset protection of driving module of fan
	H4	Drive PFC protection of fan	H5	Over-current protection of inverter fan
	H6	Drive IPM module protection of fan	H7	Malfunction of drive temperature sensor of fan
	H8	Drive IPM high temperature protection of fan	H9	Desynchronizing protection of inverter fan
	HA	Malfunction of drive storage chip of inverter outdoor fan	HH	High-voltage protection of fan's drive DC bus bar
	HC	Malfunction of current detection circuit of fan drive	HL	Low voltage protection of bus bar of fan drive
	HE	Phase-lacking of inverter fan	HF	Malfunction of charging loop of fan drive
	HJ	Failure startup of inverter fan	HP	AC current protection of inverter fan
	HU	AC input voltage of drive of inverter fan	G0	PV reversed connection protection
	G1	PV anti-islanding protection	G2	PV DC overcurrent protection
	G3	PV power generation overload	G4	PV leakage current protection
	G5	Phase-lacking protection at power grid side	G6	PV LVRT
	G7	Grid over/underfrequency protection	G8	Overcurrent protection at power grid side
	G9	Drive IPM module protection at power grid side	GA	Low/high input voltage protection at power grid side
	GH	Photovoltaic DC/DC protection	GC	Photovoltaic DC hardware overcurrent protection
	GL	Grid side hardware overcurrent protection	GE	High or low photovoltaic voltage protection
	GF	DC bus neutral-point potential unbalance protection	GJ	Grid side module high-temperature protection

DC Inverter Multi VRF System

—	Error Code	Content	Error Code	Content
Outdoor	GP	Grid side temperature sensor protection	GU	Charging circuit protection
	Gb	Grid side relay protection	Gd	Grid side current side protection
	Gn	Insulation resistance protection	Gy	Power protection (PV)
Debugging	U0	Preheat time of compressor is insufficient	U2	Wrong setting of ODU's capacity code/jumper cap
	U3	Power supply phase sequence protection	U4	Refrigerant-lacking protection
	U5	Wrong address for driving board of compressor	U6	Alarm because valve is abnormal
	U8	Malfunction of pipeline for IDU	U9	Malfunction of pipeline for ODU
	UC	Setting of main IDU is succeeded	UL	Emergency operation DIP switch code of compressor is wrong
	UE	Charging of refrigerant is invalid	UF	Identification malfunction of IDU of mode exchanger
	Ud	Drive board of grid-connection is abnormal	Un	Communication malfunction between the drive board of grid-connection and the main board
	Uy	PV module over-temperature protection	C0	Communication malfunction between IDU, ODU and IDU's wired controller
	C1	Communication malfunction between main control and DC-DC controller	C2	Communication malfunction between main control and inverter compressor driver
	C3	Communication malfunction between main control and inverter fan driver	C4	Malfunction of lack of IDU
	C5	Alarm because project code of IDU is inconsistent	C6	Alarm because ODU quantity is inconsistent
	C7	Abnormal communication of converter	C8	Emergency status of compressor
	C9	Emergency status of fan	CA	Emergency status of module
	CH	Rated capacity is too high	CC	No main unit
	CL	The matching ratio of rated capacity for IDU and ODU is too low	CE	Communication malfunction between mode exchanger and IDU
	CF	Malfunction of multiple main control units	CJ	Address DIP switch code of system is shocking
	CP	Malfunction of multiple wired controller	CU	Communication malfunction between IDU and the receiving lamp
	Cb	Overflow distribution of IP address	Cd	Communication malfunction between mode exchanger and ODU
Cn	Malfunction of network for IDU and ODU of mode exchanger	Cy	Communication malfunction of mode exchanger	
Status	A0	Unit waiting for debugging	A2	Refrigerant recovery operation of after-sales
	A3	Defrosting	A4	Oil-return
	A6	Heat pump function setting	A7	Quiet mode setting
	A8	Vacuum pump mode	A9	Set Back function
	AH	Heating	AC	Cooling
	AL	Charge refrigerant automatically	AE	Charge refrigerant manually
	AF	Fan	AJ	Cleaning reminding of filter
	AP	Debugging confirmation when starting up the unit	AU	Long-distance emergency stop
	Ab	Emergency stop of operation	Ad	Limit operation
	An	Child lock status	Ay	Shielding status
	n0	SE operation setting of system	n1	Defrosting cycle K1 setting
	n3	Compulsory defrosting	n4	Limit setting for max. capacity/output capacity

—	Error Code	Content	Error Code	Content
Status	n5	Compulsory excursion of engineering code of IDU	n6	Inquiry of malfunction
	n7	Inquiry of parameters	n8	Inquiry of project code of IDU
	n9	Check quantity of IDU on line	nA	Heat pump unit
	nH	Heating only unit	nC	Cooling only unit
	nE	Negative code	nF	Fan model
	nJ	High temperature prevention when heating	nU	Eliminate the long-distance shielding command of IDU
	nb	Bar code inquiry	nn	Length modification of connection pipe of ODU
	qA	Heat recovery status	qH	Mainly heating
	qC	Mainly cooling	qP	Export region setting for PV VRF units
	qU	Grid voltage configuration	-	-

8 After-sales Service

In case the air-conditioning unit you bought has any quality problem or you have any inquiry, please contact the local after-sales service agency designated by ASAMI.

Warranty should meet the following requirements:

- (1) First run of the unit should be operated by professional personnel from ASAMI appointed service center.
- (2) Only ASAMI manufactured accessories can be used on the machine.
- (3) All the instructions listed in this manual should be followed.
- (4) Warranty will be automatically invalid if fails to obey any item mentioned above.



66129937487