



Owner's Manual

Original Instructions

Commercial Air Conditioners

GMV DC Inverter VRF

Models:

AMV5-O785

AMV5-O900

Thank you for choosing commercial air conditioners. Please read this Owner's Manual carefully before operation and retain it for future reference.

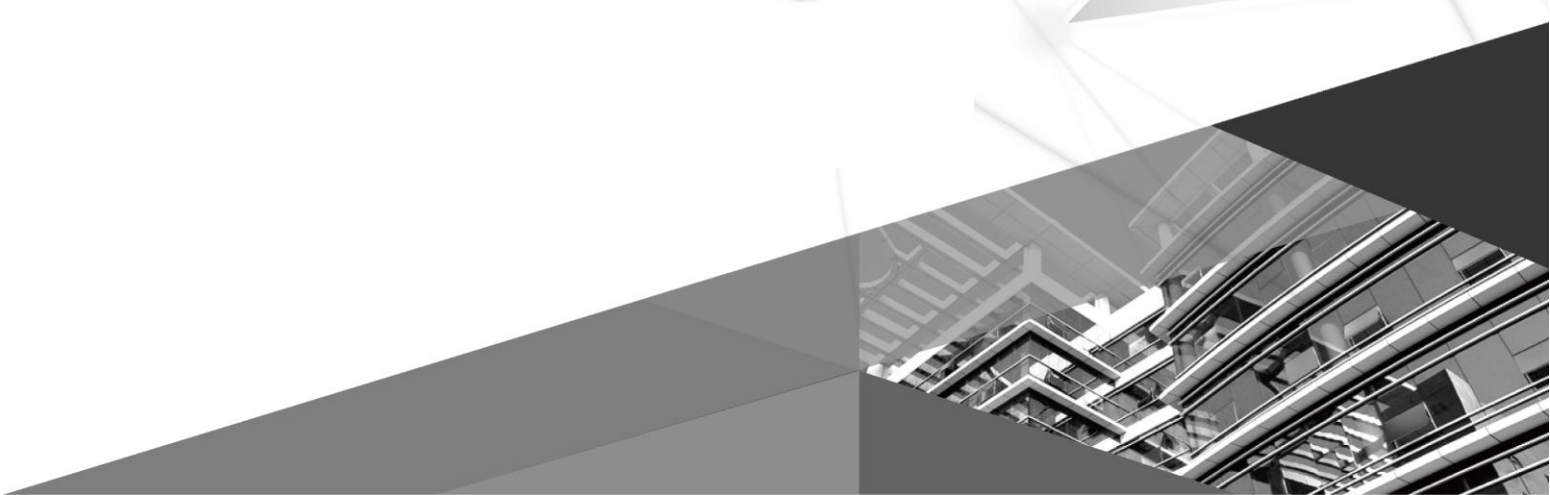

To Users

Thank you for selecting ASAMI's product. Please read this instruction manual carefully before installing and using the product, so as to master and correctly use the product. In order to guide you to correctly install and use our product and achieve expected operating effect, we hereby instruct as below:

- (1) This appliance can be used by children aged from 8 years and above and persons with reduced physical, sensory or mental capabilities or lack of experience and knowledge if they have been given supervision or instruction concerning use of the appliance in a safe way and understand the hazards involved. Children shall not play with the appliance. Cleaning and user maintenance shall not be made by children without supervision.
- (2) In order to ensure reliability of product, the product may consume some power under stand-by status for maintaining normal communication of system and preheating refrigerant and lubricant. If the product is not to be used for long, cut off the power supply; please energize and preheat the unit in advance before reusing it.
- (3) Please properly select the model according to actual using environment, otherwise it may impact the using convenience.
- (4) This product has gone through strict inspection and operational test before leaving the factory. In order to avoid damage due to improper disassembly and inspection, which may impact the normal operation of unit, please do not disassemble the unit by yourself. You can contact with the special maintenance center of our company if necessary.
- (5) When the product is faulted and cannot be operated, please contact with our maintenance center as soon as possible by providing the following information.
 - 1) Contents of nameplate of product (model, cooling/heating capacity, product No., ex-factory date).
 - 2) Malfunction status (specify the situations before and after the error occurs).
- (6) All the illustrations and information in the instruction manual are only for reference. In order to make the product better, we will continuously conduct improvement and innovation. We have the right to make necessary revision to the product from time to time due to the reason of sales or production, and reserve the right to revise the contents without further notice.
- (7) The final right to interpret for this instruction manual belongs to ASAMI.

Exception Clauses





Manufacturer will bear no responsibilities when personal injury or property loss is caused by the following reasons:









- (1) Damage the product due to improper use or misuse of the product;
- (2) Alter, change, maintain or use the product with other equipment without abiding by the instruction manual of manufacturer;
- (3) After verification, the defect of product is directly caused by corrosive gas;
- (4) After verification, defects are due to improper operation during transportation of product;
- (5) Operate, repair, maintain the unit without abiding by instruction manual or related regulations;
- (6) After verification, the problem or dispute is caused by the quality specification or performance of parts and components that produced by other manufacturers;
- (7) The damage is caused by natural calamities, bad using environment or force majeure.











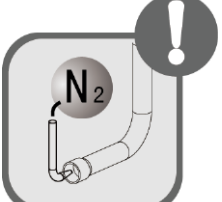

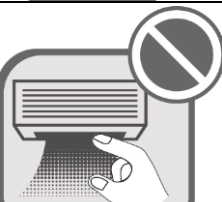

Contents



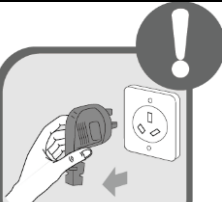

1 Safety Notices (Please be sure to abide)	1
2 Product Introduction	4
2.1 Names of Main Parts	4
2.2 Combinations of Indoor and Outdoor Units.....	4
2.3 The Range of Production Working Temperature.....	5
3 Preparation before Installation	6
3.1 Standard Parts	6
3.2 Installation Site.....	6
3.3 Piping Work Requirements	13
4 Installation Instruction	13
4.1 ODU Foundation	13
4.2 Physical Dimension of the Outdoor Unit and Mounting Hole	14
4.3 Connection Pipe.....	15
4.4 Installation of the Connection Pipe	20
4.5 Air Purging and Refrigerant Charge.....	24
4.6 Electric Wiring	27
4.7 System Communication	29
4.8 Connection Method and Steps for System Communication.....	32
4.9 External Electrical Wiring Diagram	36
5 Check Items after Installation and Trial Run	37
5.1 Check Items after Installation.....	37
5.2 Trial Run.....	37
6 Common Malfunction and Troubleshooting	50
7 Error Indication	51
8 Maintenance and Care	55
8.1 Outdoor Heat Exchanger	55
8.2 Drain Pipe	55
8.3 Notice before Seasonal Use	55
8.4 Maintenance after Seasonal Use.....	55
8.5 Parts Replacement	55
9 After-sales Service	56

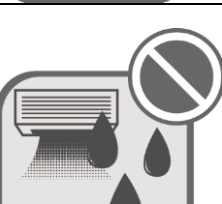
1 Safety Notices (Please be sure to abide)

-  Warning: If not abide strictly, it may cause severe damage to the unit or the people.
-  Note: If not abide strictly, it may cause slight or medium damage to the unit or the people.
-  This sign indicates that the operation must be prohibited. Improper operation may cause severe damage or death to people.
-  This sign indicates that the items must be observed. Improper operation may cause damage to people or property.
-  **WARNING!**
This product can't be installed at corrosive, inflammable or explosive environment or the place with special requirements, such as kitchen. Otherwise, it will affect the normal operation or shorten the service life of the unit, or even cause fire hazard or serious injury. As for above special places, please adopt special air conditioner with anti-corrosive or anti-explosion function.

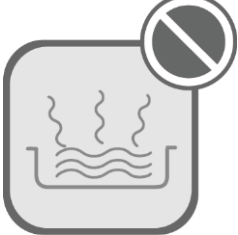
	<p>Follow this instruction to complete the installation work. Please carefully read this manual before unit startup and service.</p>		<p>Installation should be conducted by dealer or qualified personnel. Please do not attempt to install the unit by yourself. Improper handling may result in water leakage, electric shock or fire disaster etc.</p>
	<p>Before installation, please check if the power supply is in accordance with the requirements specified on the nameplate. And also take care of the power safety.</p>		<p>Make sure the unit can be earthed properly and soundly after plugging into the socket so as to avoid electric shock. Please do not connect the ground wire to gas pipe, water pipe, lightning rod or telephone line.</p>
	<p>Be sure to use the exclusive accessory and part to prevent the water leakage, electric shock and fire accidents.</p>		<p>If refrigerant leakage happens during installation, please ventilate immediately. Poisonous gas will emerge if the refrigerant gas meets fire.</p>
	<p>Wire size of power cord should be large enough. The damaged power cord and connection wire should be replaced by exclusive cable.</p>		<p>After connecting the power cord, please fix the electric box cover properly in order to avoid accident.</p>

	<p>Never fail to comply with the nitrogen charge requirements. Charge nitrogen when welding pipes.</p>		<p>Never short-circuit or cancel the pressure switch to prevent unit damage.</p>
	<p>Please firstly connect the wired controller before energization, otherwise wired controller can not be used.</p>		<p>Before using the unit, please check if the piping and wiring are correct to avoid water leakage, refrigerant leakage, electric shock, or fire etc.</p>
	<p>Do not insert fingers or objects into air outlet/inlet grille.</p>		<p>Open the door and window and keep good ventilation in the room to avoid oxygen deficit when the gas/oil supplied heating equipment is used.</p>
	<p>Never start up or shut off the air conditioner by means of directly plug or unplug the power cord.</p>		<p>Turn off the unit after it runs at least five minutes; otherwise it will influence oil return of the compressor.</p>
	<p>Do not allow children operate this unit.</p>		<p>Do not operate this unit with wet hands.</p>
	<p>Turn off the unit or cut off the power supply before cleaning the unit, otherwise electric shock or injury may happen.</p>		<p>Never spray or flush water towards unit, otherwise malfunction or electric shock may happen.</p>
	<p>Do not expose the unit to the moist or corrosive circumstances.</p>		<p>Electrify the unit 8 hours before operation. Please switch on for 8 hours before operation. Do not cut off the power when 24 hours short-time halting (to protect the compressor).</p>

	<p>Volatile liquid, such as diluent or gas will damage the unit appearance. Only use soft cloth with a little neutral detergent to clean the outer casing of unit.</p>		<p>Under cooling mode, please don't set the room temperature too low and keep the temperature difference between indoor and outdoor unit within 5.</p>
	<p>If anything abnormal happens (such as burning smell), please power off the unit and cut off the main power supply, and then immediately contact ASAMI appointed service center. If abnormality keeps going, the unit might be damaged and lead to electric shock or fire.</p>		<p>User is not allowed to repair the unit. Fault service may cause electric shock or fire accidents. Please contact ASAMI appointed service center for help.</p>

ASAMI will not assume responsibility of personal injury or equipment damage caused by improper installation and commission, unnecessary service and incapable of following the rules and instructions listed in this manual.

DISPOSAL: Do not dispose this product as unsorted municipal waste. Collection of such waste separately for special treatment is necessary.



2 Product Introduction

ASAMI Multi VRF System adopts inverter compressor technology. According to change the displacement of compressor, stepless capacity regulation within range of 10%-100% can be realized. Various product lineup is provided with capacity range from 78.5kW to 90kW, which can be widely used in working area and especially applicable to the place with variable load change. ASAMI air conditioner is absolutely your best choice.

2.1 Names of Main Parts

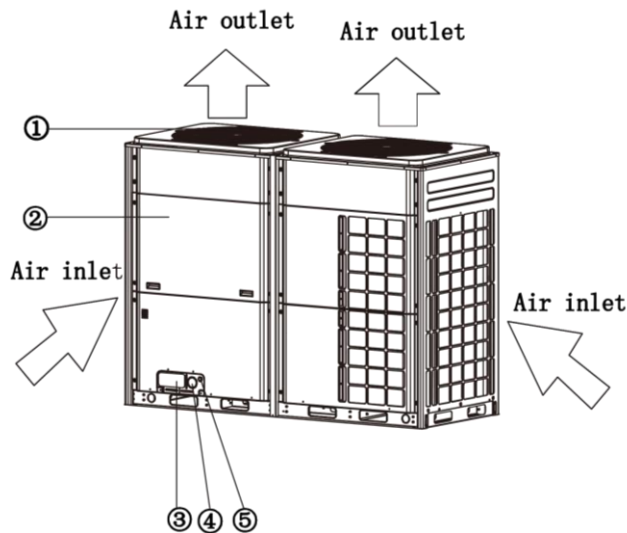

Fig.1

NO.	①	②	③	④	⑤
Name	Fan, Motor	Electric Box Assembly	Valve interface	Power cord through-hole	Communication code through-hole

2.2 Combinations of Indoor and Outdoor Units

(1) The following table indicates the number of IDU for ODU

ODU model	Max number of connectable IDU (unit)
AMV5-O785	46
AMV5-O900	53

(2) The total capacity of indoor units should be within 50%~135% of that of outdoor units.

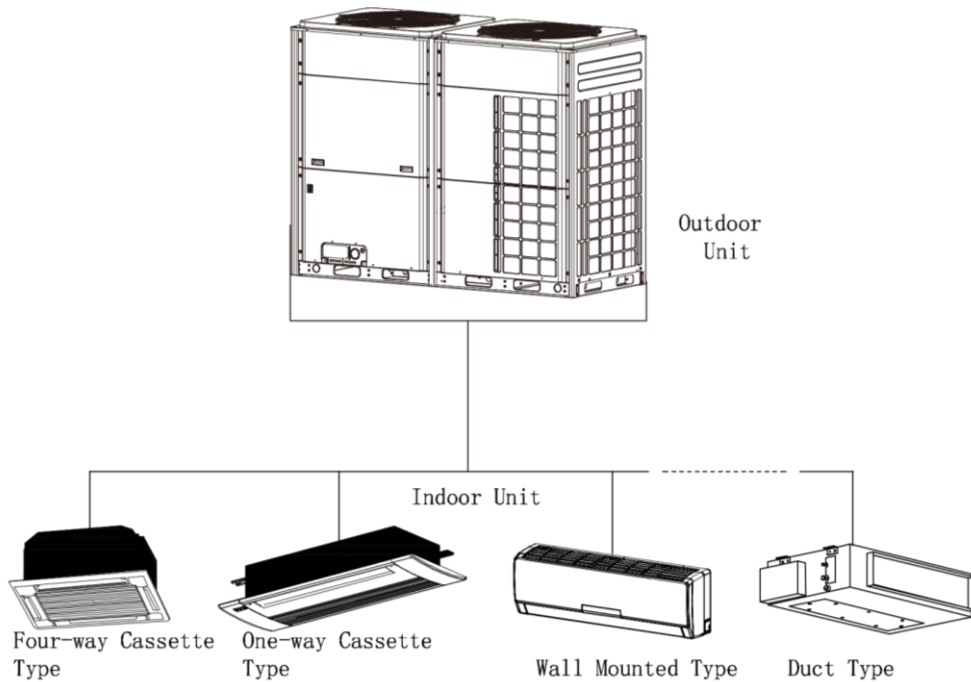

Fig.2

(3) Fig.2 is the combination view of the ODU of Modular DC Inverter Multi VRF System and the IDU of Multi VRF System. IDU can be cassette type, one-way cassette type, wall-mounted type, duct type, etc. When any one IDU receives operation signal, ODU will start to work according to the capacity; when all IDUs stop, ODU will also stop.

2.3 The Range of Production Working Temperature

Cooling	Ambient temperature: -5℃ ~52℃
Heating	Ambient temperature: -20℃ ~24℃

When the indoor units are all VRF fresh air processor, the unit operating range is as follows:

Cooling	Ambient temperature: 16℃~45℃
Heating	Ambient temperature: -7℃~16℃



Note: Out of the working Temperature Range may damage this product and will invalidate the warranty.

3 Preparation before Installation

Note: The picture is only used for reference and the actual product prevails. Unit: mm.

3.1 Standard Parts

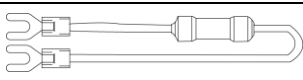



Please use the following standard parts supplied by ASAMI.

Parts for Outdoor Unit				
Number	Name	Picture	Quantity	Remarks
1	Owner's Manual		1	
2	Wiring (match with resistance)		1	
3	Mark (Master)		2	Attach on the wired controller of master IDU or on the front panel

3.2 Installation Site

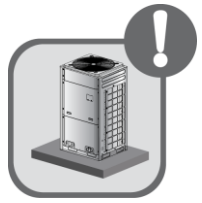
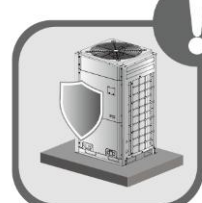
 **Forbidden Items!** It indicates that improper operation might lead to human casualty or sever injury.

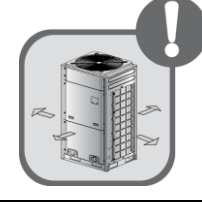
 **Items need to be followed.** It indicates that improper operation might lead to personal injury or property damage.

	Install the unit at a place where is adequate to withstand the weight of the unit and make sure the unit would not shake or fall off.		The installation position should withstand strong wind, typhoon and earthquake. The unit must be installed stably.
	Try to keep the unit away from combustible, inflammable and corrosive gas or exhaust gas.		Leave some space for heat exchanging and servicing so as to guarantee unit normal operation.
	Keep the indoor and outdoor units close to each other as much as possible so as to decrease the pipe length and bends.		Never allow children to approach to the unit and take measures to prevent children touching the unit.

3.2.1 When the outdoor unit is totally surrounded by walls, please refer to following figures for space dimension.

3.2.1.1 Space dimension for single outdoor unit

unit:mm

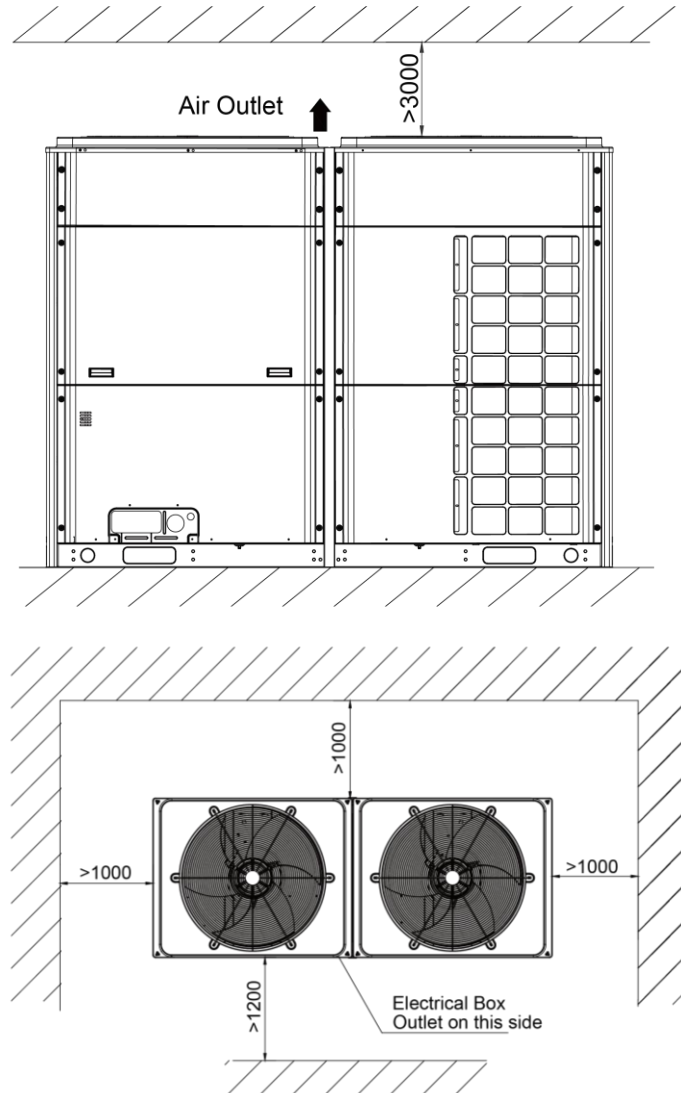

Fig. 3

3.2.1.2 Space dimension for two outdoor units

unit:mm

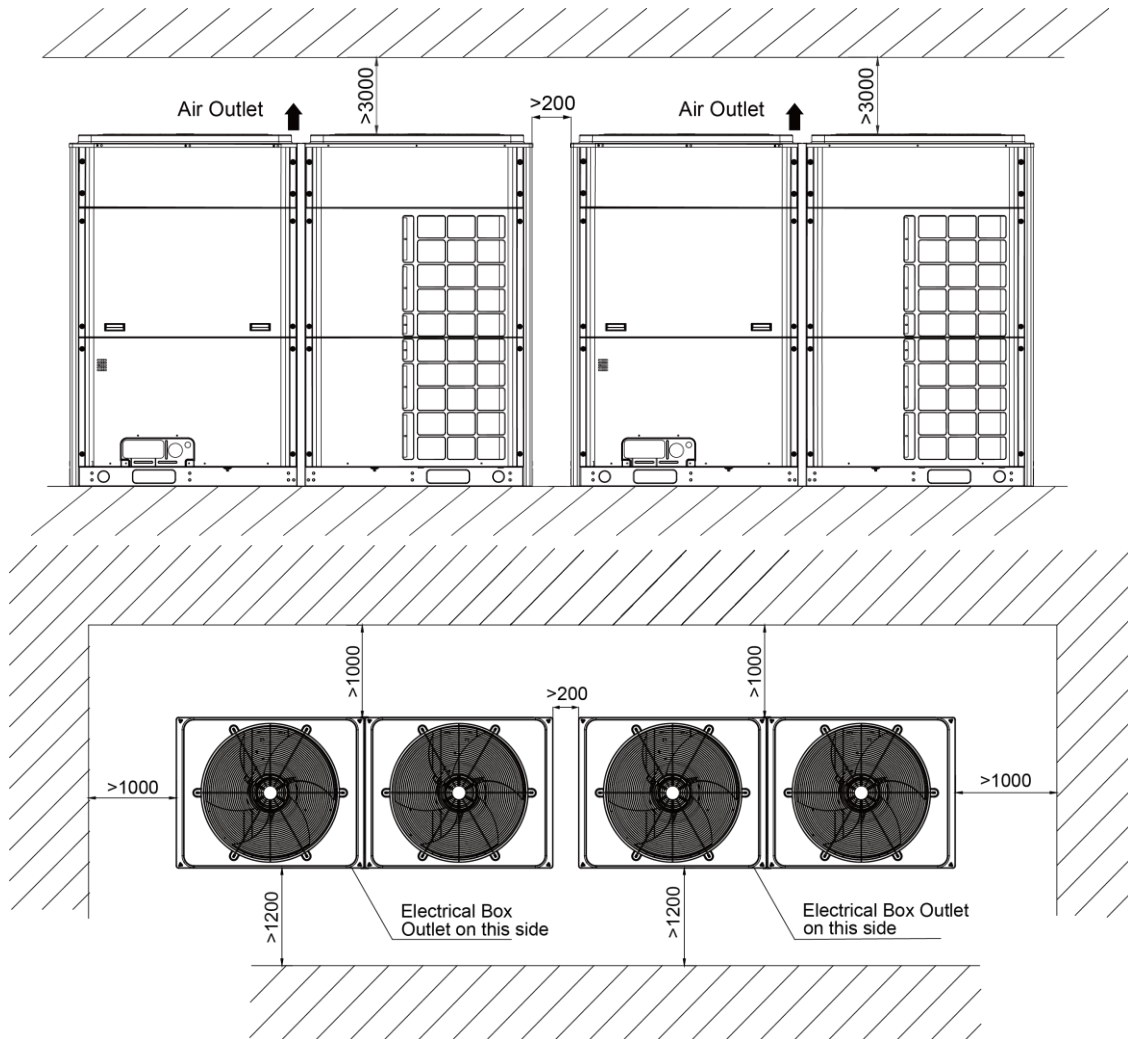

Fig. 4

3.2.1.3 Space dimension for three outdoor units

unit:mm

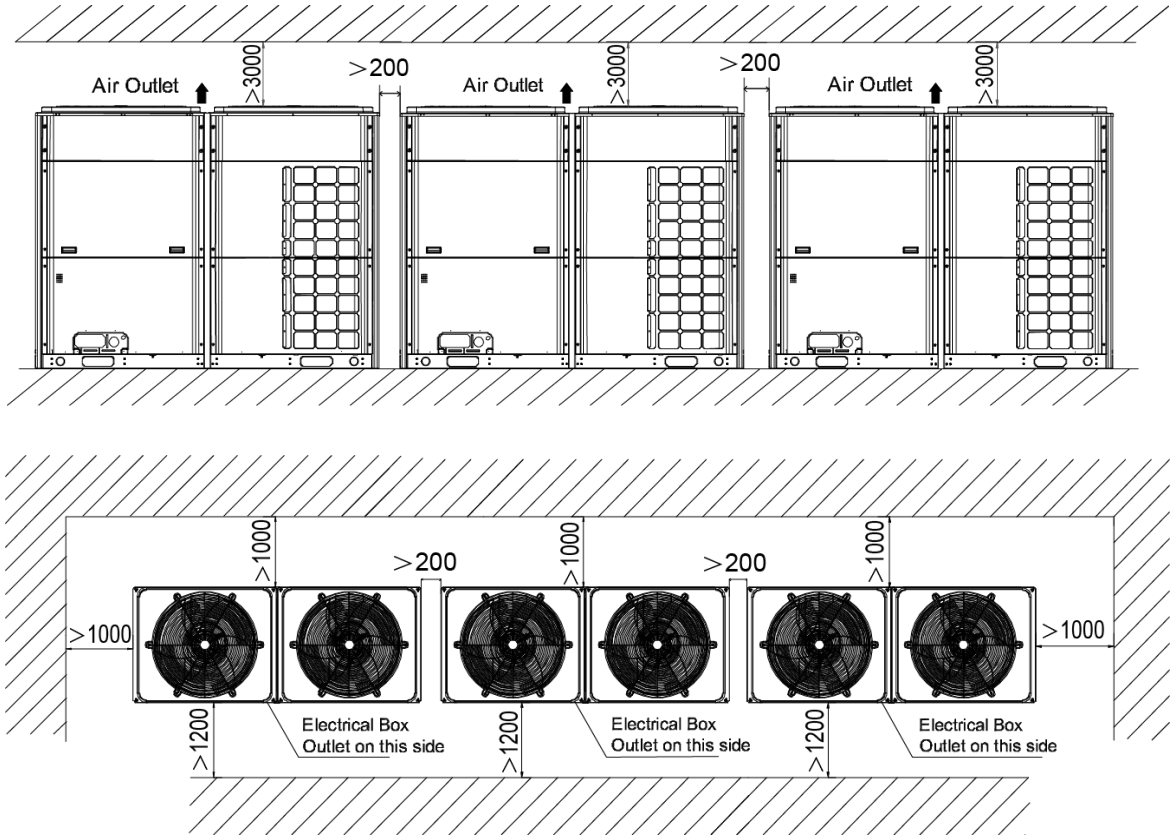

Fig.5

3.2.1.4 Space dimension for four outdoor units

unit:mm

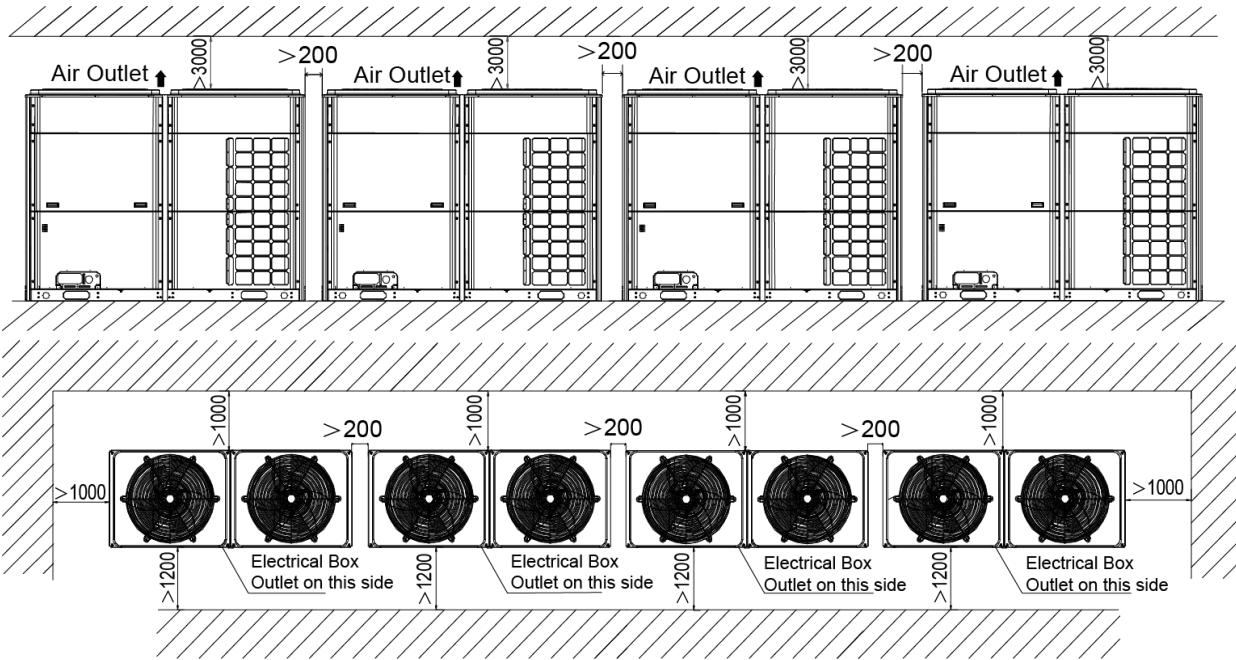

Fig.6

3.2.2 Space dimension for outdoor unit top

When there is wall (or similar obstruction) above the unit, keep the distance between the unit top and the wall at least 3000mm or above. When the unit is located in a totally open space with no obstructions in four directions, keep the distance between the unit top and wall at least 1500mm or above (See Fig.7). When space is limited within 1500mm or the unit is not set in an open space, air outlet pipe is required to be installed in order to keep good ventilation (See Fig.8).

unit:mm

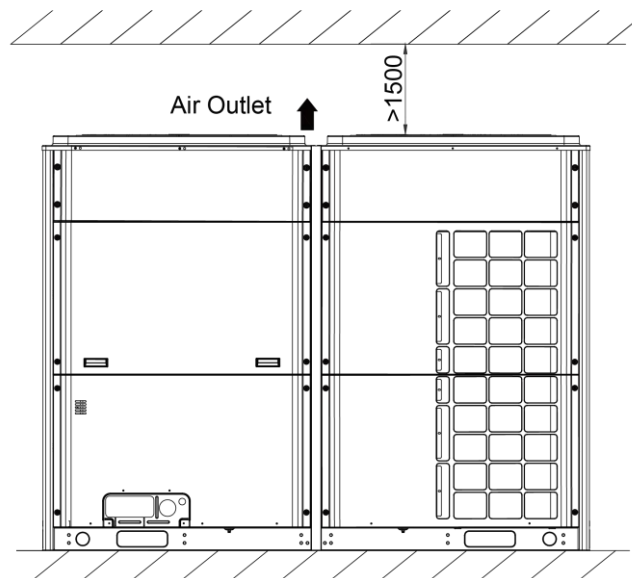

Fig.7

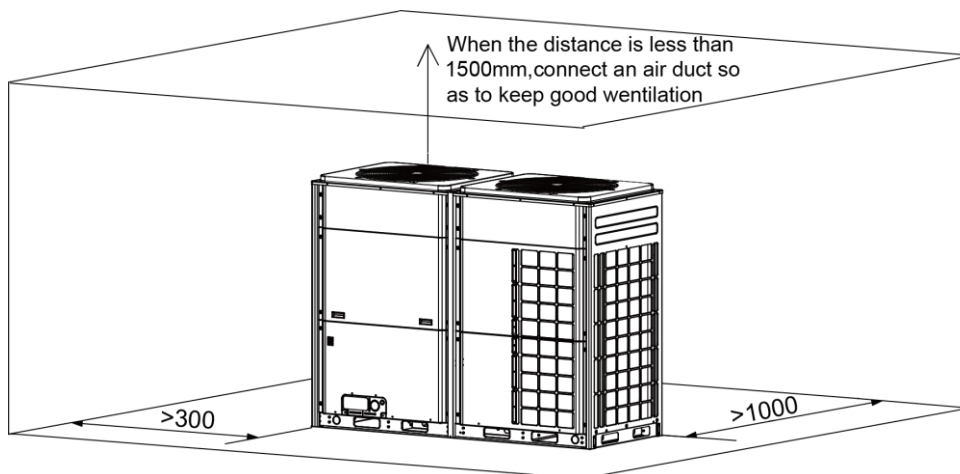

Fig.8

3.2.3 Space dimension for multiple unit

For keeping good ventilation, make sure there is no obstructions above the unit.

When the unit is located at a half-open space (front and left/right side is open), install the unit as per the same or opposite direction.

unit:mm

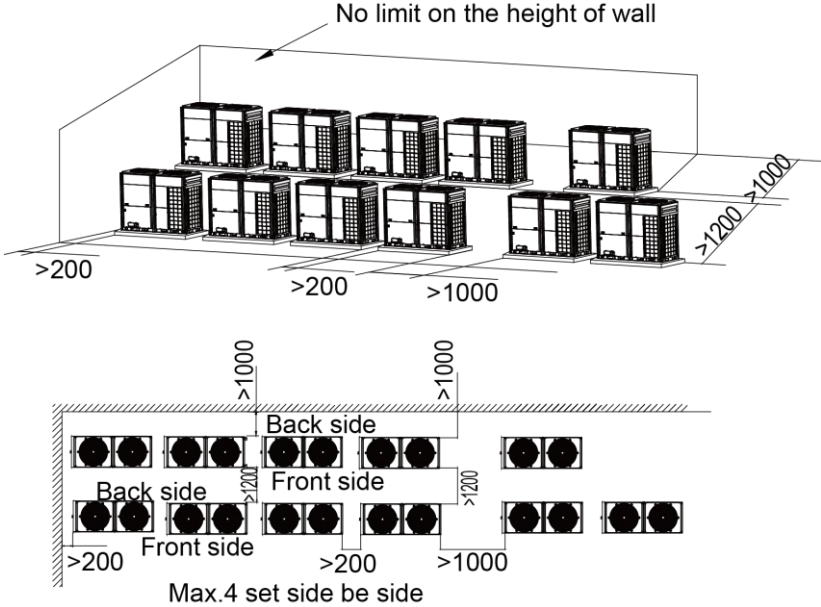

Fig.9

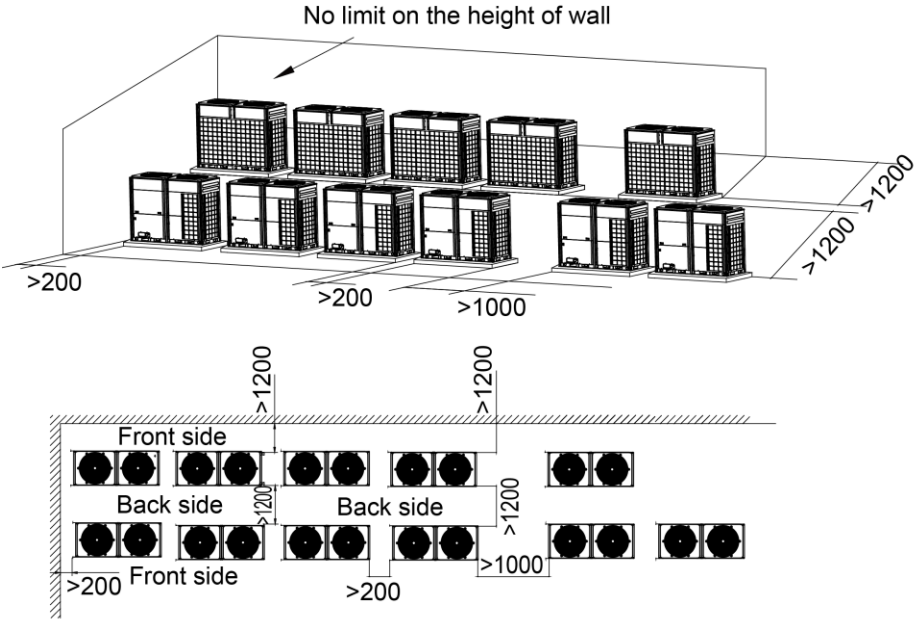

Fig.10

3.2.4 Take seasonal wind into consideration when installing the outdoor unit

(1) Anti-monsoon installation requirements for unit not connecting exhaust duct:

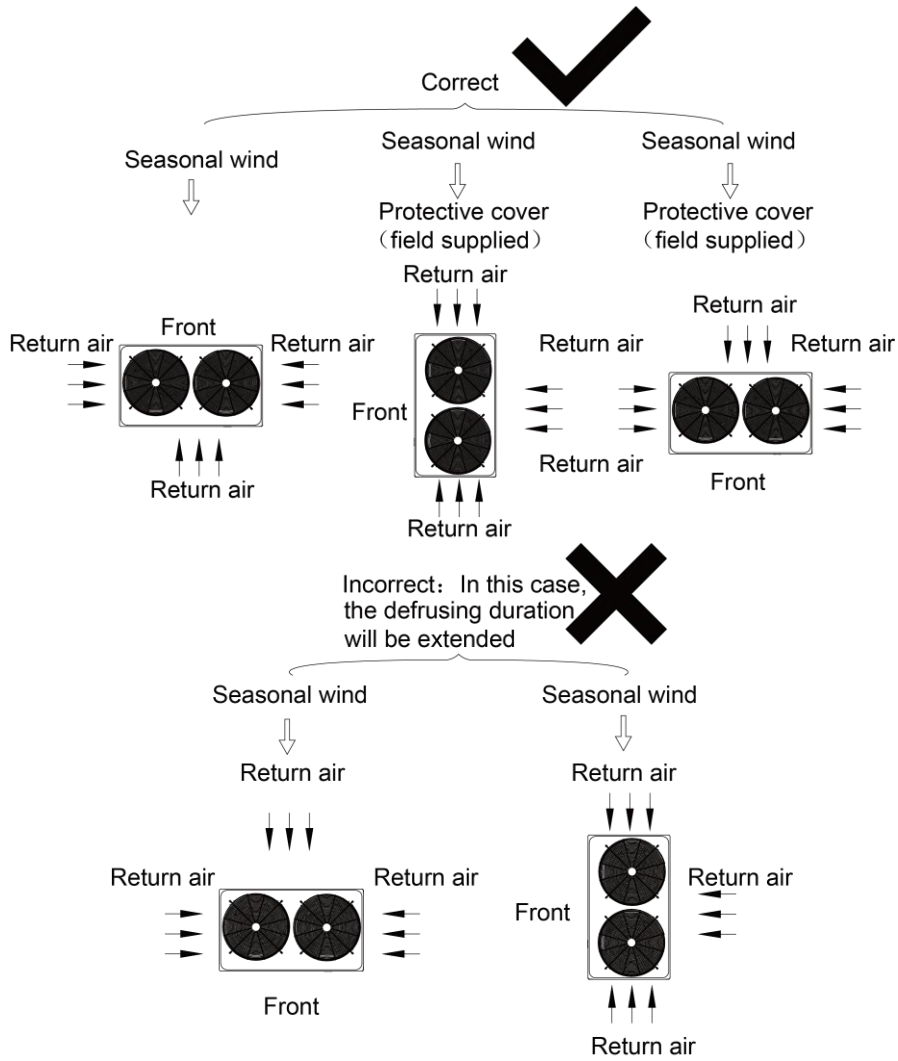

Fig.11

(2) Anti-monsoon installation requirements for unit connecting exhaust duct:

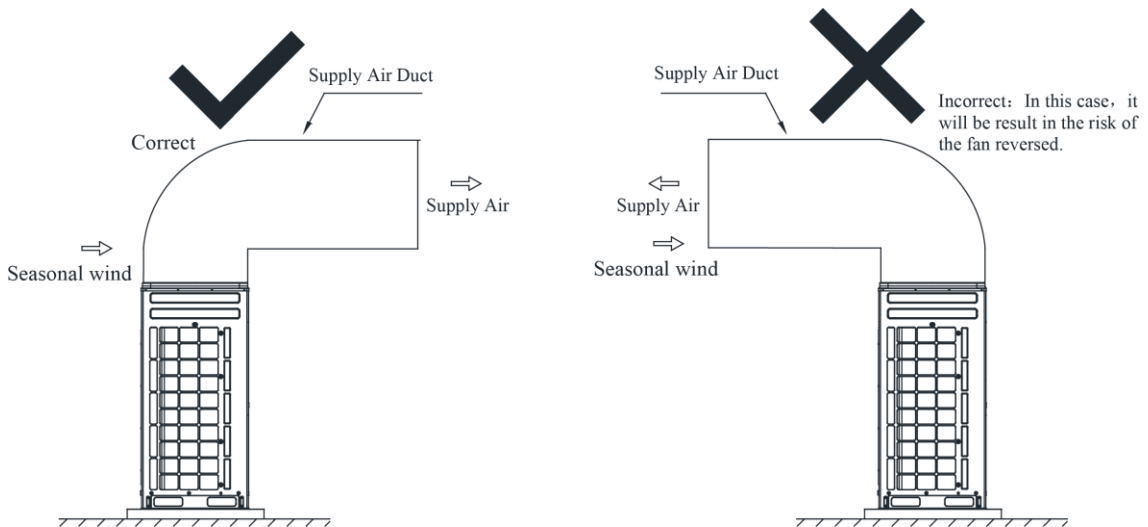

Fig.12

3.2.5 Take snow into consideration when installing the outdoor unit

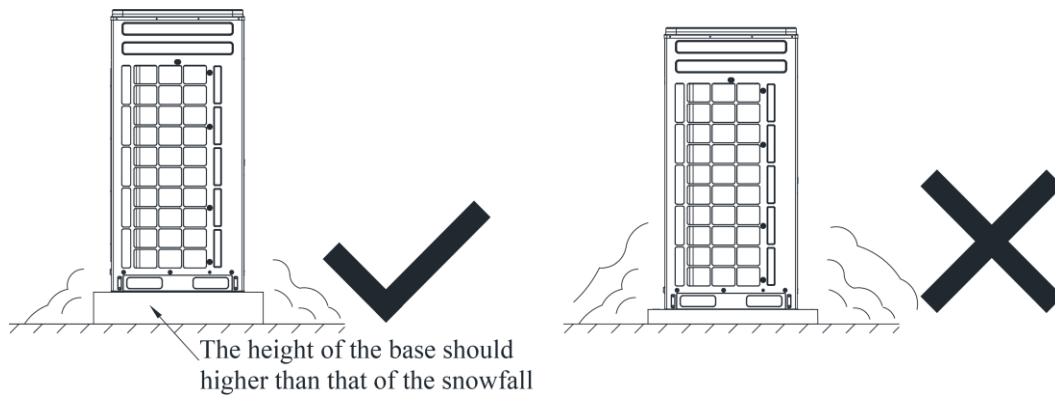

Fig.13

3.3 Piping Work Requirements

There should be no fall among outdoor modules. Refer to the table below for piping work requirements.

R410A Refrigerant System		
Outer Diameter (mm)	Wall Thickness (mm)	Type
Φ6.35	≥0.8	O
Φ9.52	≥0.8	O
Φ12.70	≥0.8	O
Φ15.9	≥1.0	O
Φ19.05	≥1.0	1/2H
Φ22.2	≥1.2	1/2H
Φ25.40	≥1.2	1/2H
Φ28.60	≥1.2	1/2H
Φ34.90	≥1.2	1/2H
Φ31.80	≥1.3	1/2H
Φ38.10	≥1.3	1/2H
Φ41.30	≥1.5	1/2H
Φ44.5	≥1.5	1/2H
Φ54.1	≥1.5	1/2H

4 Installation Instruction

4.1 ODU Foundation

The concrete foundation of the ODU must be strong enough. Ensure that the drainage is smooth and that the ground drainage or floor drainage is not affected.

Requirements on the concrete foundation are as follows:

- A. The concrete foundation must be flat and have enough rigidity and strength to undertake the unit's weight during running. The height of the foundation is 200 mm to 300 mm, which is determined based on the size of the unit.
- B. Build a drainage ditch around the foundation to discharge the condensate water.
- C. If the air conditioner is installed on the roof, check the intensity of the building and take waterproof measures.

D. If a u-steel foundation is adopted, the structure must be designed with sufficient rigidity and strength.

Anchor bolt with a nominal diameter of 12mm

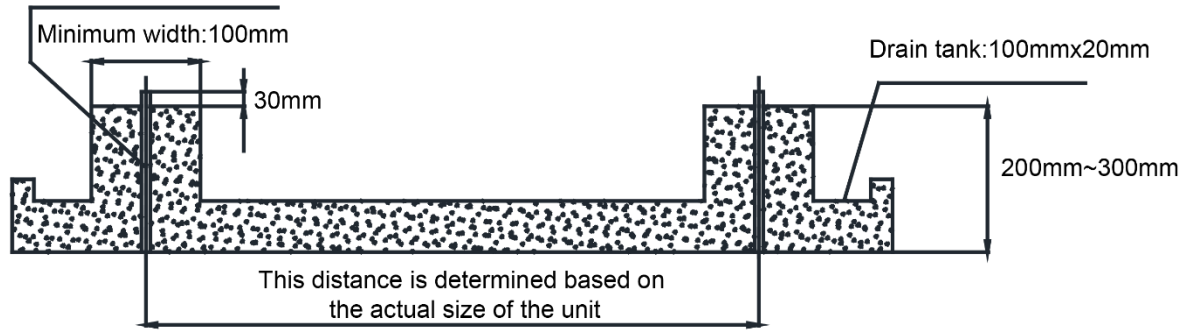

Cement foundation diagram
Fig. 14

4.2 Physical Dimension of the Outdoor Unit and Mounting Hole

Outline and Physical Dimension of AMV5-O785 and AMV5-O900 unit.

Unit:mm

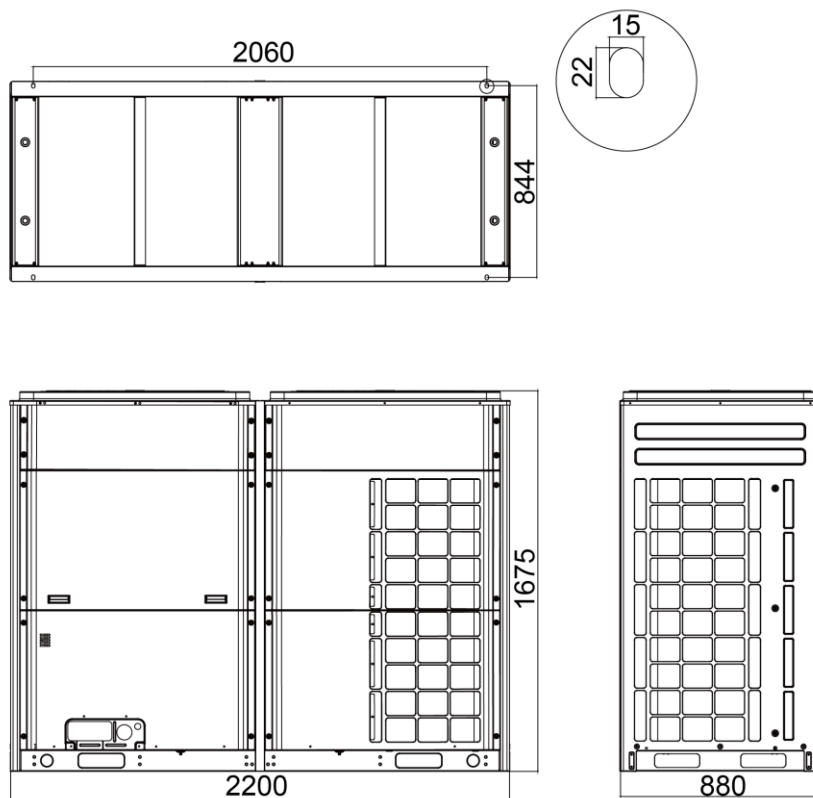

Fig.15

4.3 Connection Pipe

4.3.1 Schematic Diagram of Piping Connection

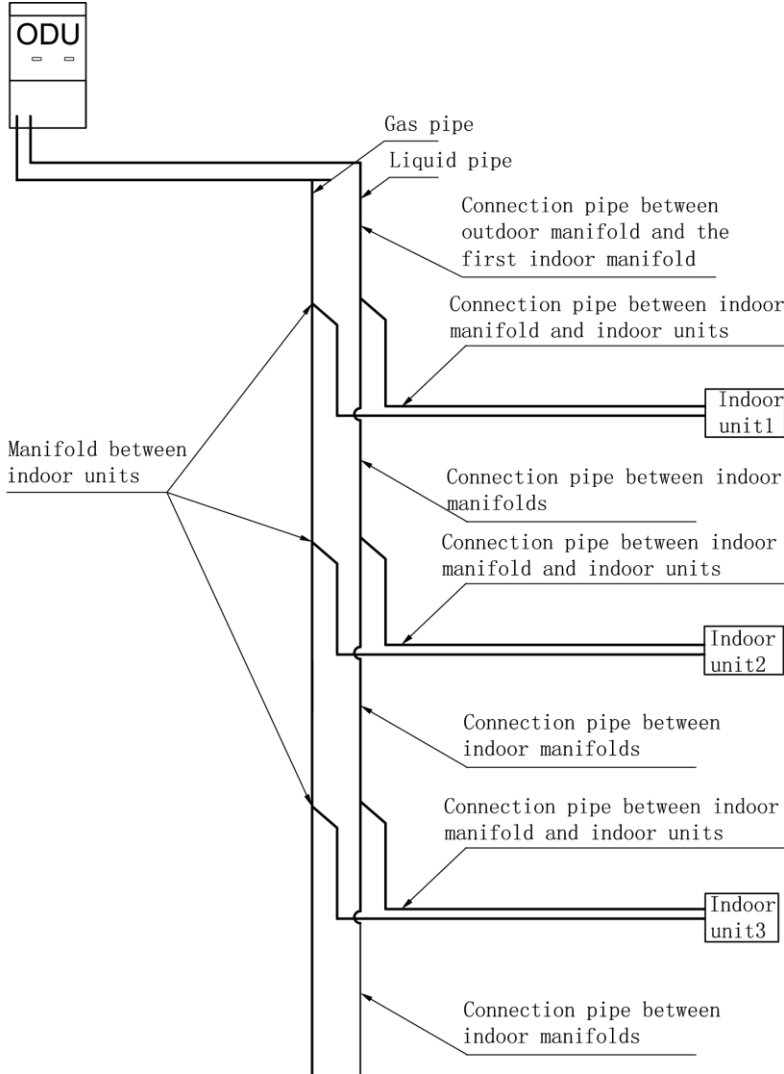

Fig.16

4.3.2 Schematic Diagram of Piping Sequence

AMV5-O785, AMV5-O900

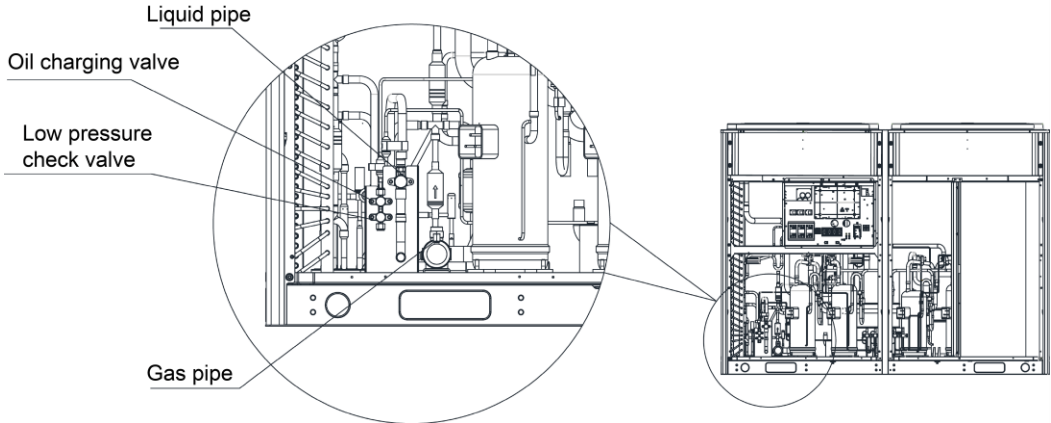

Fig.17

4.3.3 Allowable pipe length and drop height among indoor and outdoor units

Y type branch joint is adopted to connect indoor and outdoor units. Connecting method is shown in the figure below.

Remark: Equivalent length of one Y-type manifold is about 0.5m.

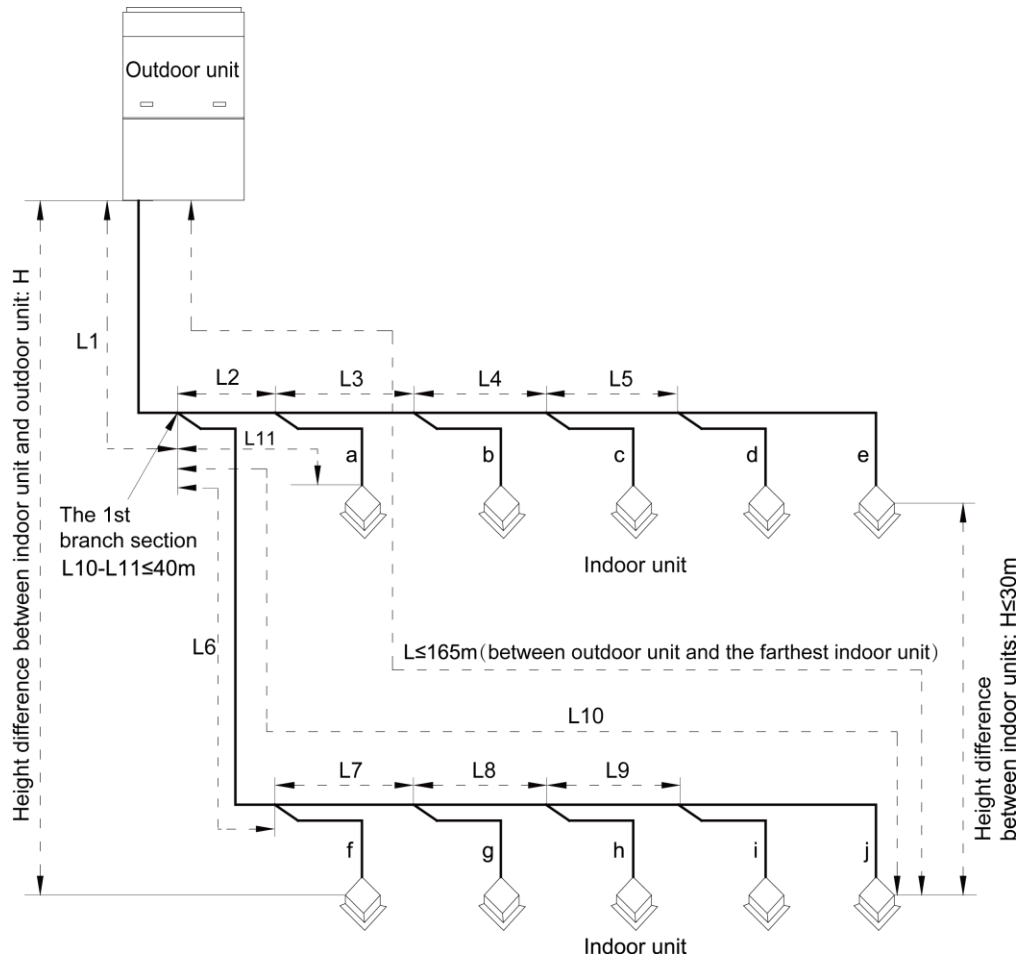

Fig.18

L10: Length from the first branch to the farthest IDU;

L11: Length from the first branch to the nearest IDU;

Equivalent length of branch of IDU is 0.5m

R410A Refrigerant System		Allowable Value	Fitting Pipe
Total length (actual length) of fitting pipe		≤500	$L1+L2+L3+L4+...+L9+a+b+...+i+j$
Length of farthest fitting pipe(m)	Actual length	≤165	$L1+L6+L7+L8+L9+j$
	Equivalent length	≤190	
Difference between the pipe length from the first branch of IDU to the farthest IDU and the pipe length from the first branch of IDU to the nearest IDU		≤40	L10-L11
Equivalent length from the first branch to the furthest piping (1)		≤40	$L6+L7+L8+L9+j$
Height difference between outdoor unit and indoor unit	Outdoor unit at upper	≤90	—
	Outdoor unit at lower	≤90	—
Height difference between indoor units (m)		≤30	—
Maximum length of Main pipe(2)		<90	L1
From IDU to its nearest branch (3)		≤40	a,b,c,d,e,f,g,h,i,j

Notices:

- ① Normally, the pipe length from the first branch of IDU to the farthest IDU is 40m. When those three conditions as below are satisfied, the length can reached 90m.
- a) Actual length of pipe in total: $L1+L2 \times 2+L3 \times 2+L4 \times 2+\dots+L9 \times 2+a+b+\dots+i+j \leq 500\text{m}$;
- b) Length between each IDU and its nearest branch a, b, c, d, e, f, g, h, i, j $\leq 40\text{m}$;
- c) Difference between the pipe length from the first branch of IDU to the farthest IDU and the pipe length from the first branch of IDU to the nearest IDU: $L10-L11 \leq 40\text{m}$.
- ② When the maximum length of the main pipe from ODU to the first branch of IDU is $\geq 90\text{m}$, then adjust the pipe size of the gas pipe and liquid pipe of main pipe according to the following table.

Outdoor Model	Gas pipe size(mm)	Liquid pipe size(mm)
AMV5-O785	$\Phi 38.1$	$\Phi 22.2$
AMV5-O900	$\Phi 38.1$	$\Phi 22.2$

- ③ If the length between an IDU and its nearest branch is above 10m, then increase the size of the liquid pipe of IDU (only for the pipe size that is $\leq 6.35\text{mm}$).

4.3.4 Fitting pipe between Outdoor Unit and the First Manifold

4.3.4.1 For single module system, pipe size (between outdoor unit and the first manifold) is determined by that of outdoor unit.

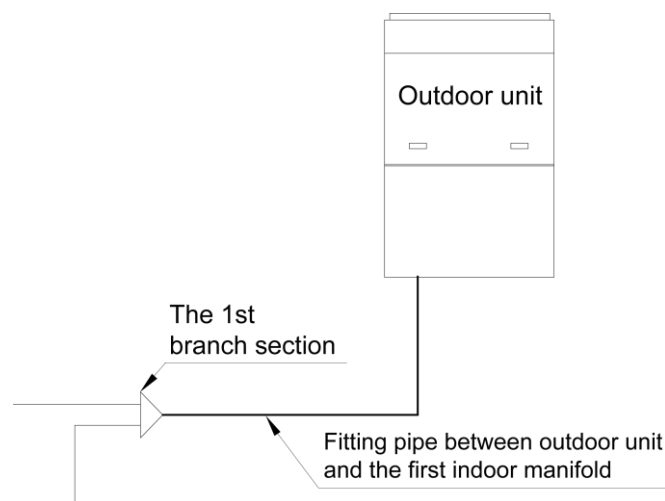

Fig.19

Pipe size of basic outdoor module is shown as follows:

Outdoor unit	Pipe between ODU and the first branch of IDU	
	Gas Pipe(mm)	Liquid Pipe(mm)
AMV5-O785	$\Phi 31.8$	$\Phi 19.05$
AMV5-O900	$\Phi 31.8$	$\Phi 19.05$

4.3.4.2 Manifold at indoor unit side

Manifold at indoor unit side can be selected as per total capacity of downstream indoor unit(s). Refer to the following table.

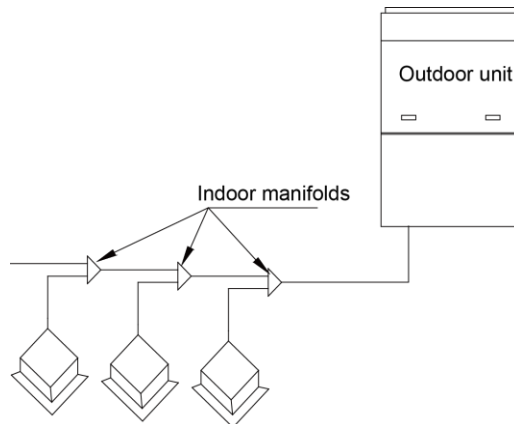

Fig.20

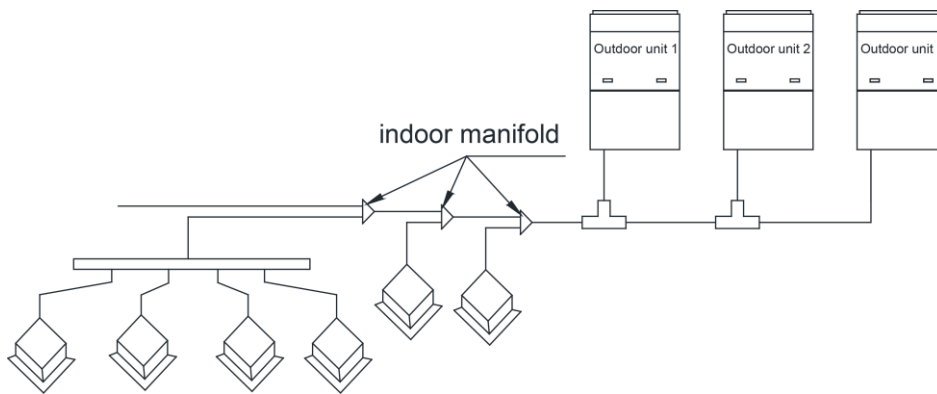

Fig.21

R410A Refrigerant System	Total capacity of downstream indoor unit(s) C (kW)	Model
Y-type Manifold	$C < 20.0$	FQ01A/A
	$20.0 \leq C \leq 30.0$	FQ01B/A
	$30.0 < C \leq 70.0$	FQ02/A
	$70.0 < C$	FQ03/A
T- type Manifold	$C \leq 40.0$	FQ14/H1
	$C \leq 68.0$	FQ18/H1
	$68.0 < C$	FQ18/H2

4.3.4.3 Fitting pipe between manifolds

Pipe size (between two manifolds at indoor unit side) is based on the total capacity of downstream indoor unit(s).

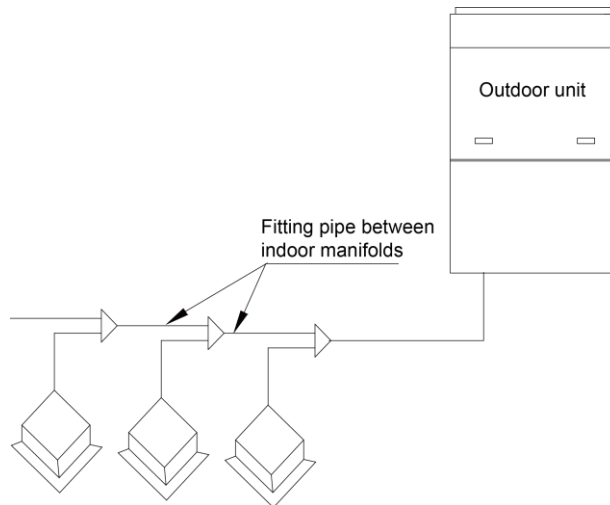

Fig.22

Total capacity of downstream indoor unit(s) C(kW)	Dimension of the pipe of indoor branch	
	Gas Pipe(mm)	Liquid Pipe (mm)
$C \leq 5.0$	$\Phi 12.7$	$\Phi 6.35$
$5.0 < C \leq 14.2$	$\Phi 15.9$	$\Phi 9.52$
$14.2 < C \leq 25.2$	$\Phi 19.05$	$\Phi 9.52$
$25.2 < C \leq 28.0$	$\Phi 22.2$	$\Phi 9.52$
$28.0 < C \leq 40.0$	$\Phi 25.4$	$\Phi 12.7$
$40.0 < C \leq 45.0$	$\Phi 28.6$	$\Phi 12.7$
$45.0 < C \leq 68.0$	$\Phi 28.6$	$\Phi 15.9$
$68.0 < C$	$\Phi 31.8$	$\Phi 19.05$

4.3.4.4 Fitting pipe between indoor unit and manifold

Manifold should be matched with fitting pipe of indoor unit.

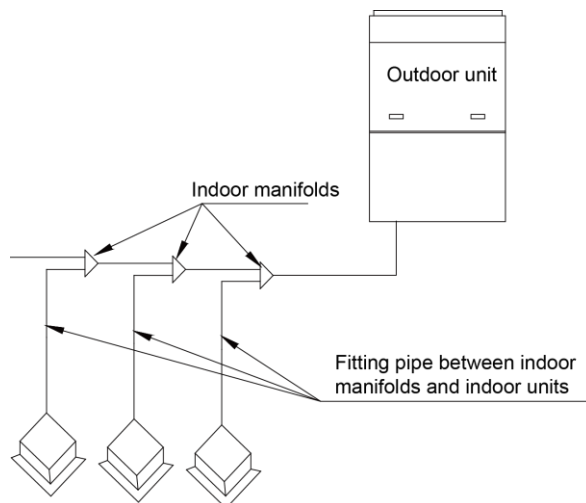

Fig.23

Rated capacity of indoor unit C(kW)	Pipe between indoor branch and IDU	
	Gas Pipe(mm)	Liquid Pipe(mm)
C≤2.8	Φ9.52	Φ6.35
2.8<C≤5.0	Φ12.7	Φ6.35
5.0<C≤14.2	Φ15.9	Φ9.52
14.2<C≤25.2	Φ19.05	Φ9.52
25.2<C≤28.0	Φ22.2	Φ9.52

4.4 Installation of the Connection Pipe

Note: Before welding the pipeline sealing cap, please make sure there's no refrigerant in pipeline. If welding it directly, it may cause unnecessary property damage or personal injury.

4.4.1 Precautions when installing the connection pipe

- (1) Conform to the following principles during piping connection: Connection pipeline should be as short as possible. The height difference between indoor and outdoor units should be as short as possible. Keep number of bends as little as possible. The radius of curvature should be as large as possible.
- (2) Weld the connection pipes between indoor and outdoor unit. Please strictly conform to the requirements for welding process. Rosin joints and pin holes are not allowable.
- (3) When laying the pipes, be careful not to deform them. The radius of bending parts should be more than 200mm. The pipes can not be repeatedly bent or stretched, otherwise the material will get harder. Do not bend or stretch the pipe over three times at the same position.
- (4) Please use a torque wrench to connect union nut on the indoor unit. See Fig. 24.

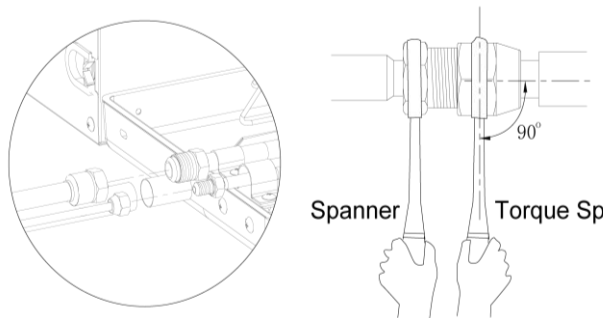

Fig.24

- 1) Align the expansion end of copper pipe with the center of threaded joint. Tighten the flare nuts with your hands.
- 2) Tighten the flare nuts with torque wrench until you hear "click" sound.
- 3) Use sponge to wrap the connecting pipe and joints without thermal insulation and tie it up with plastic tape.
- 4) A mounting support for the connection pipe is required.
- 5) The curvature degree of connection pipe should not be small, otherwise the pipe might crack. Installation personnel should use tube bender when bending the pipe.
- 6) Don't forcibly stretch the pipe joint, otherwise indoor capillary or other pipes might be damaged and lead to refrigerant leakage.

4.4.2 Manifold

(1) Y-type manifold, See the Fig. 25. T-type manifold, See the Fig.26

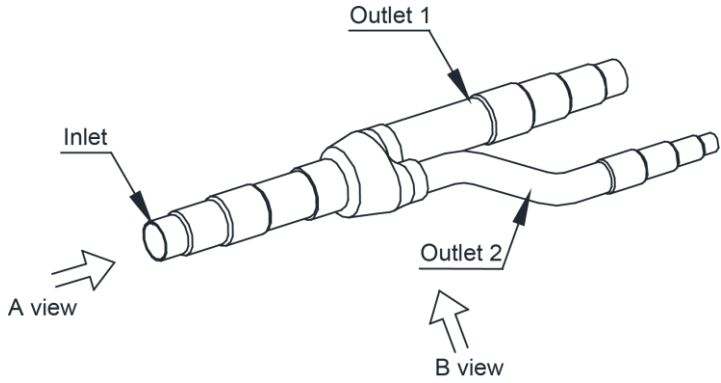

Fig. 25

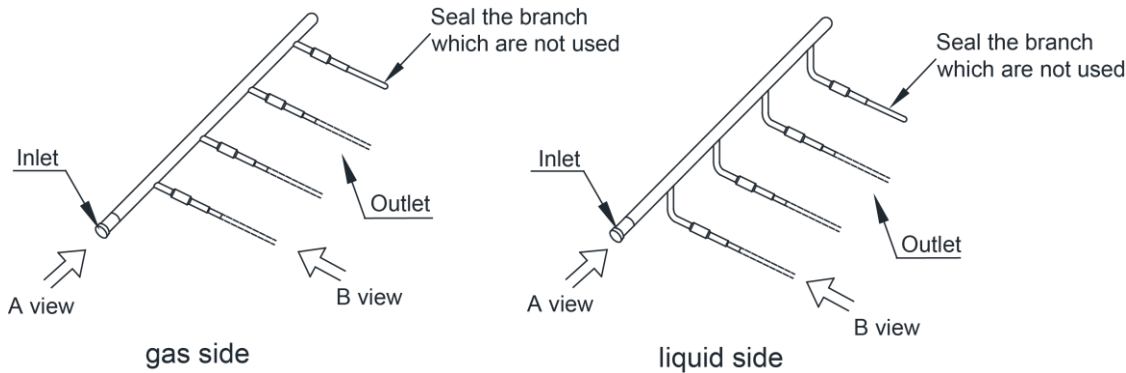
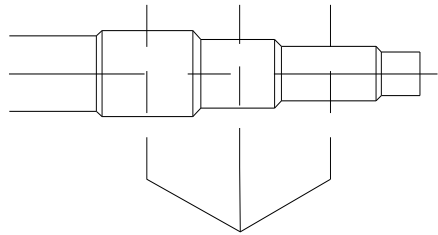

Fig. 26

(2) Manifold has several pipe sections with different pipe size, which facilitates to match with various copper pipe. Use pipe cutter to cut in the middle of the pipe section with different pipe size and deburr as well. See Fig.27.



Cut from the center

Fig.27

(3) Y-type manifold can be installed vertically or horizontally. Confirm the position and then weld the manifold pipe. See the Fig.28. T-type manifold must be installed horizontally with inclination, see the Fig.29.

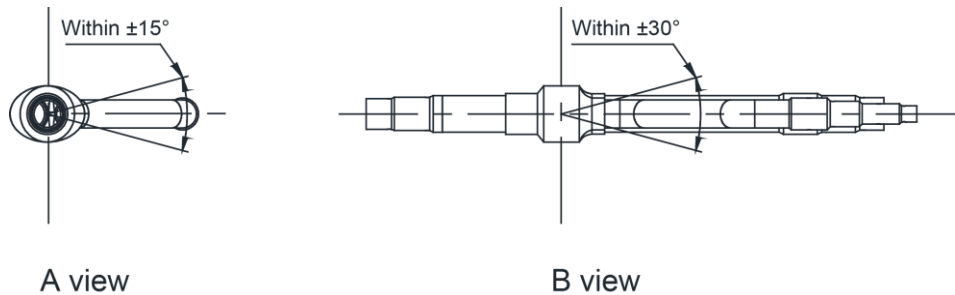

Fig.28

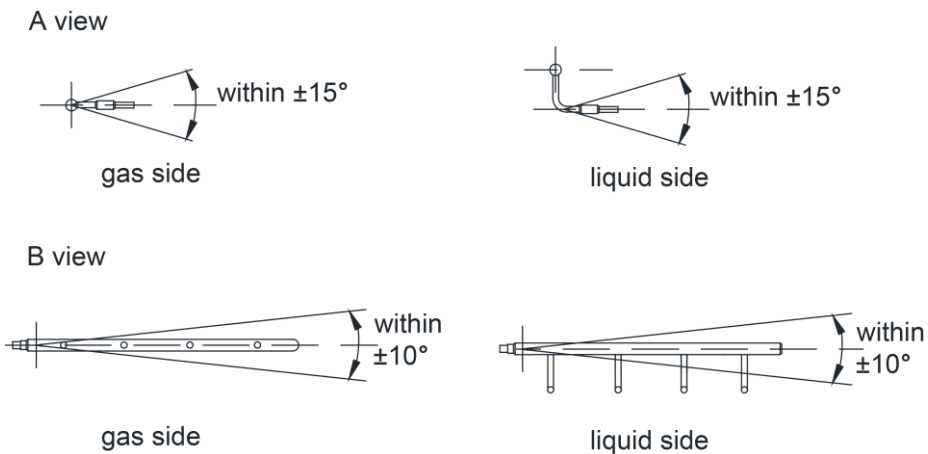

Fig.29

- (4) Manifold is isolated by insulating material that can bear 120°C or higher temperature. Manifold attached foam can not be taken as insulating material.

4.4.3 Installation and thermal insulation for pipeline

- (1) For multi VRF system, every copper pipe should be labeled so as to avoid misconnection.
 (2) Manifolds can be laid in the following ways:

The length of a straight pipe between two manifolds cannot be less than 500 mm. The length of a straight pipe before the main pipe port of the manifold cannot be less than 500 mm. The length of a straight pipe between the branch of the manifold and the IDU cannot be less than 500 mm. See Fig.30.

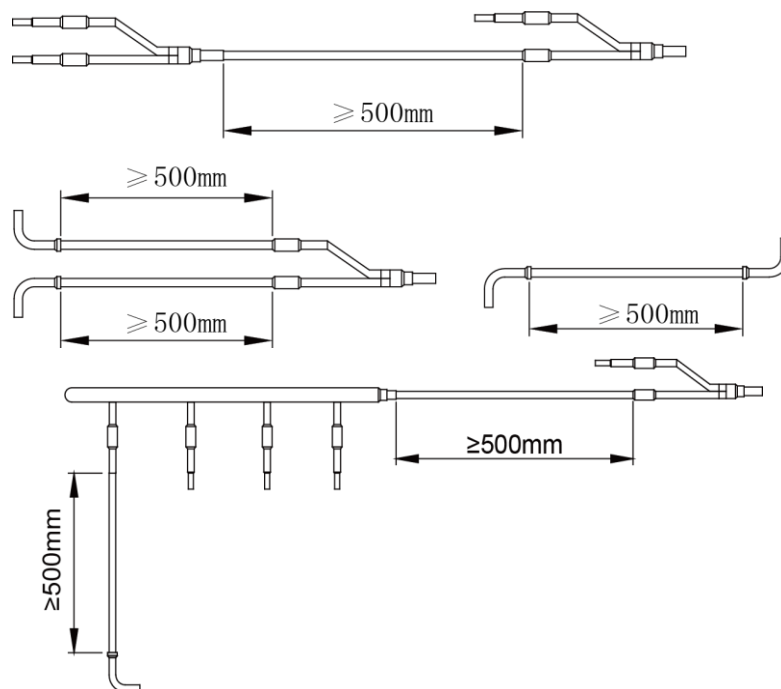

Fig.30

- (3) There must be three fixing point for both horizontal and vertical installation of the Y-type manifold. See Fig.31.

Fixing point 1: 100 mm on the main inlet manifold from the welding point

Fixing point 2: 200 mm on the main branched pipe from the welding point

Fixing point 3: 250 mm on the branched pipe from the welding point

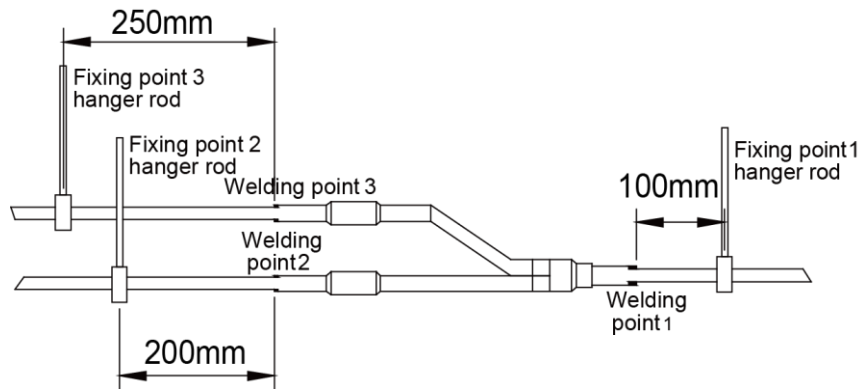

Fig.31

(4) Suspend the header to the ceiling, and be sure to install the T-type manifold so that the outlet pipes are horizontal at the lower side. See Fig.32.

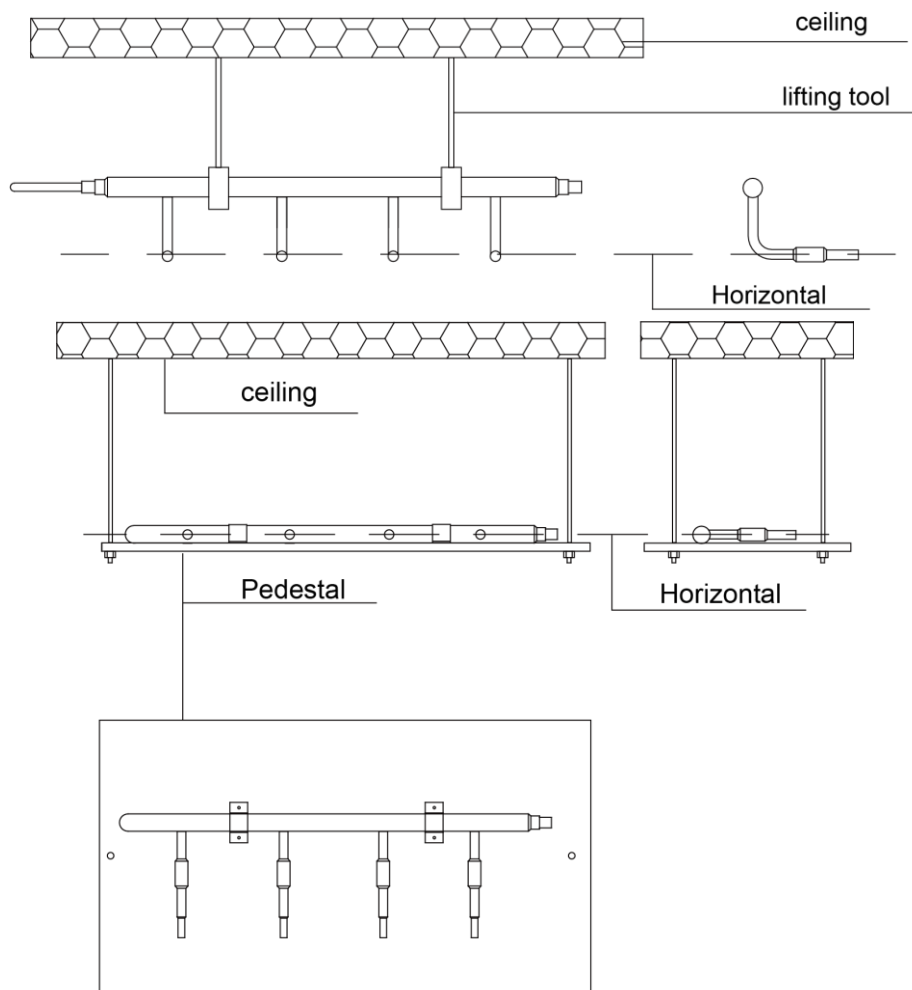

Fig.32

(5) Thermal insulation for pipeline

- 1) To avoid condensate or water leakage on connecting pipe, the gas pipe and liquid pipe must be wrapped with thermal insulating material and adhesive pipe for insulation from the air.

- 2) For heat pump unit, liquid pipe should bear 70°C or above, and gas pipe should bear 120°C or above. For cooling only unit, both liquid pipe and gas pipe should bear 70°C or above. Example: Polyethylene foam can bear 120°C above and foaming polyethylene can bear 100°C above.
- 3) Joints at indoor and outdoor units should be wrapped with insulating material and leave no clearance between pipe and wall. See Fig.33.

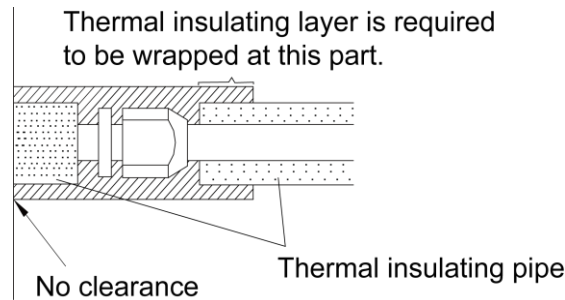

Fig.33

- 4) Manifold attached foam can not be taken as insulating material.
- 5) When wrapping the tape, the later circle should cover half of the former one. Don't wrap the tape so tightly, otherwise the insulation effect will be weakened.
- 6) After wrapping the pipe, adopt sealing material to completely fill the hole so as to prevent wind and rain from entering the room.

4.4.4 Support and protection for pipeline

- (1) Support should be made for hanging connection pipe. Distance between each support can not be over 1m.
- (2) Protection towards accidental damage should be made for outdoor pipeline. When the pipeline exceeds 1m, a pinch board should be added for protection.

4.5 Air Purging and Refrigerant Charge

4.5.1 Air purging

Confirm outdoor liquid and gas valves are closed. Air purging from the nozzle located on liquid and gas valves by vacuum pump. See Fig.34.

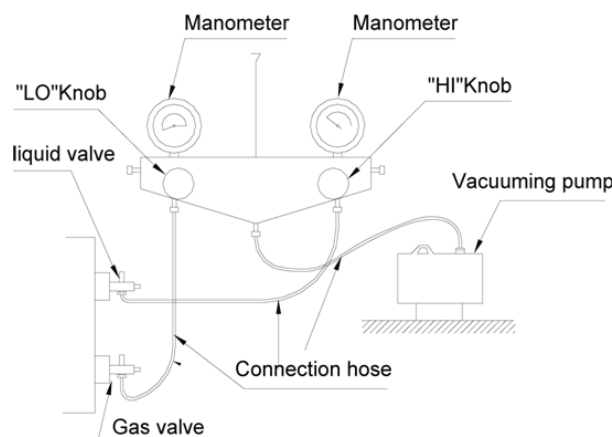

Fig.34

4.5.2 Additional refrigerant charging

Outdoor unit has been charged refrigerant before delivery.

Charge additional refrigerant for field-installed connecting pipe. If the pipeline is longer than 1m, please refer to the following table for charging amount of refrigerant. (Liquid pipe prevails)

How much additional refrigerant should be charged

Additional refrigerant amount R=additional refrigerant amount for piping A + additional refrigerant amount for outdoor unit B

(1) Pipeline charging amount

Pipeline charging amount A= \sum Liquid pipe length \times refrigerant charging amount of every 1m liquid pipe

Diameter of liquid pipe (mm)	Φ28.6	Φ25.4	Φ22.2	Φ19.05	Φ15.9	Φ12.7	Φ9.52	Φ6.35
kg/m	0.680	0.520	0.350	0.250	0.170	0.110	0.054	0.022

(2) Refrigerant amount for outdoor unit B

Refrigerant amount for outdoor unit B (kg)②		outdoor unit capacity(kW)	
IDU/ODU rated capacity collocation ratio C ①	Quantity of included IDUs	78.5	90.0
50% \leq C \leq 70%	<4	0	0
	\geq 4	2	2
70%<C \leq 90%	<4	3	3
	\geq 4	3.5	4
90%<C \leq 105%	<4	4	4
	\geq 4	5	6
105%<C \leq 135%	<4	5	6
	\geq 4	7	8

Note:

- ① IDU/ODU rated capacity collocation ratio C = Sum of rated cooling capacity of indoor unit / Sum of rated cooling capacity of outdoor unit.
- ② If all indoor units are fresh air processing units, the additional refrigerant charge amount of each module (B) should be 0kg.
- ③ If outdoor air processor is connected with normal VRF indoor unit, adopt the perfusion method for normal indoor unit for perfusion.

Example:

The OUD is 90kw. The IDUs are made up of 7 sets of 14kw.

IDU/ODU rated capacity collocation ratio C= $140 \times 7 / 900 = 109\%$. The quantity of included IDUs is more than 4 sets. Please refer to the above table.

Rrefrigerant charging amount B for 90kw is 8.0kg.

Suppose the Pipeline charging amount A= \sum Liquid pipe length \times refrigerant charging amount of every 1m liquid pipe=4.7kg.

Total refrigerant charging amount R=8+4.7=12.7kg.

After confirming that there is no leakage from the system, when the compressor is not in

operation, charge additional R410A with specified amount to the unit through the filling opening of the liquid pipe valve of the outdoor unit. If required additional refrigerant can not be quickly filled for increase of pressure in the pipe, set the unit at cooling startup and then fill the refrigerant from gas valve of outdoor unit. If ambient temperature is low, the unit can't be set to cooling mode but heating mode.

4.5.3 Precautions on Refrigerant Leakage

- (1) Personnel related to air conditioning engineering design and installation operators must abide by the safety requirement for preventing refrigerant leakage specified in local laws and regulations.
- (2) The units adopt the R410A refrigerant, which is nonflammable and nontoxic. However, the space for refrigerant leakage must be sufficient to ensure that the refrigerant concentration does not exceed that specified in the safety requirement; otherwise, people involved can be stifled by the refrigerant. For example the maximum allowed concentration level of refrigerant to a humanly space for R410A according to the appropriate European Standard is limited to 0.44 kg/m³.

The maximum amount of refrigerant (kg) in the system = The volume of the room (m³) × The maximum allowed concentration level of refrigerant (kg/m³)

Total amount of refrigerant (kg) in the system = Total additional charging amount (kg) + Amount of refrigerant (kg) which is charged before leaving the factory (for the system consisting of multiple modules in parallel, the accumulative charge quantity of modules before leaving the factory is used)

Total amount of refrigerant (kg) in the system ≤ The maximum amount of refrigerant (kg) in the system

- (3) When the total amount of refrigerant in the system is more than the maximum amount of refrigerant, the cooling system should be designed again. In this case, the cooling system can also be separated into several cooling systems with small capacity, or add corresponding ventilation measures or alarming display.

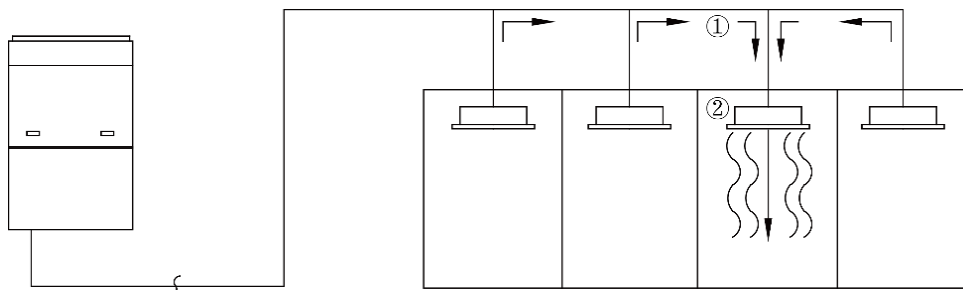

Fig. 35

- ① Flow direction of refrigerant leakage.
- ② Room for refrigerant leakage. Since the concentration of refrigerant is greater than that of air, pay attention to the spaces where the refrigerant may residue, for example, the basement.

4.6 Electric Wiring

4.6.1 Wiring precautions

- ◆ Wiring should conform to national rules. All the parts, materials, electric work should be in accordance with local codes.
- ◆ Rated voltage and exclusive power supply should be used.
- ◆ Power cord should be fixed soundly and reliable. Never forcibly pull the power cord.
- ◆ Wire size of power cord should be large enough. The damaged power cord and connecting wire should be replaced by exclusive cable.
- ◆ All the electrical work should be performed by professional personnel as per local law, regulation and this manual.
- ◆ Connect the unit to the special earthing device and make sure the unit is earthed soundly.
- ◆ Circuit breaker and circuit breaker is required to be set. Circuit breaker should have both magnetic trip and thermal trip functions so as to protect the unit when short-circuit and overload happens. D-type breaker is advised to be used.
- ◆ Wiring diagram attached on the unit is prevailed.

4.5.2 Wiring of power cord

Every unit should have corresponding short-circuit and overload protection. And also a main switch is required to control power supply or disconnection. See Fig.36.

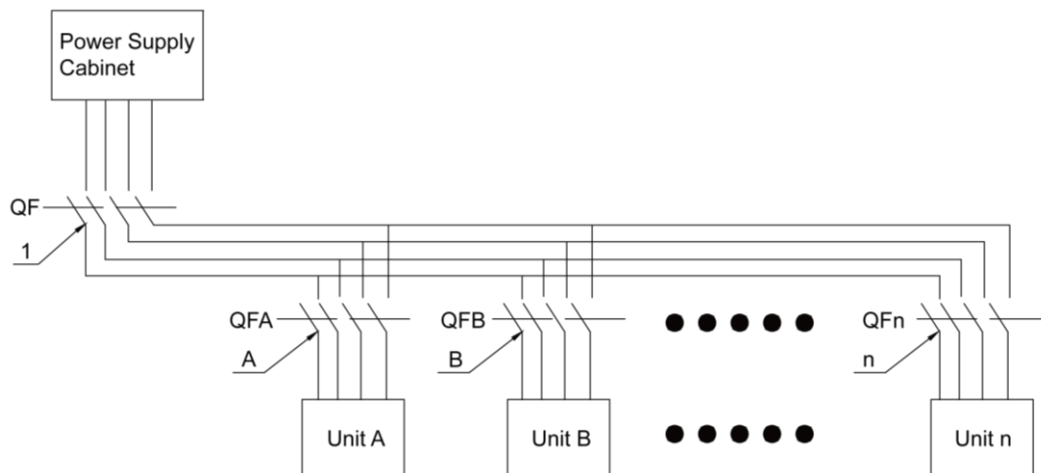

Fig.36

Please refer to the following table for circuit breaker and circuit breaker for modular outdoor units. 5-core cable is used and the wire size unit is mm².

Model	Power Supply	Capacity of circuit breaker (A)	Minimum Sectional Area of Grounding Wire(mm ²)	Minimum Sectional Area of Power Cord (mm ² ×mm ²)
AMV5-O785	380V-415V 3N~ 50Hz	63	16.0	25×3+16×2
AMV5-O900	380V-415V 3N~ 50Hz	80	16.0	25×3+16×2

Note:

- ① Specification of circuit breaker and power cord is selected on the basis of unit's maximum power (max. current).
- ② Specification of power cord is based on the working condition where ambient temperature is 40°C and multi-core copper cable (working temperature is 90°C) is lying on the surface of slot (IEC 60245). If working condition changes, please adjust the specification according to standard IEC 60245. Power cord used for outdoor unit should not be below standard 60245 IEC57.
- ③ Copper-core cable must be used.
- ④ The above sectional area is suitable for a maximum distance of 15m. If it's over 15m, sectional area must be expanded to prevent overload current from burning the wire or causing fire hazard.
- ⑤ Specification of circuit breaker is based on the working condition where the ambient temperature of circuit breaker is 40°C. If working condition is different, please adjust the specification according to national standard.
- ⑥ The circuit breaker should include magnetic trip function and thermal trip function so that system can be protected from short circuit and overload.
- ⑦ An all-pole disconnection switch having a contact separation of at least 3mm in all poles should be connected in fixed wiring

4.6.3 Connection of power cord

Warning: before obtaining access to terminals, all supply circuits must be disconnected.

Note:

- ① If units are type I electrical appliances, they must be reliably grounded.
- ② Ground resistance must be in accord with requirements of local standard.
- ③ The green-yellow wire within units are ground wire. Do not use it for other purposes. Nor should it be cut off or secured by tapping screws. Otherwise, it may cause electric shock.
- ④ Power supply at user side must have reliable ground terminal. Do not connect ground wire to the following places:
 - a) Water pipe, b) gas pipe, c) drainage pipe, d) other places that are considered by professionals as unreliable.

Power cord and communication wire should be separated, with a distance of more than 20cm. Otherwise, system's communication may not work well.

- ⑤ Steps and graphic of power cord connection:
 - a) Knock off the cross-through opening that's used for leading the external power cord, with the cross-through rubber ring on the opening. Then lead the cable through the opening. Connect L1, L2, L3, N of power cord and ground wire separately to the positions on wiring board (for power supply) that are marked with L1, L2, L3, N and

- the ground screw nearby.
- b) Fasten the power cord with cable tie.
- c) Lay the power cable and communication cable for the ODU according to the marker of external connection circuit diagram.

4.7 System Communication

4.7.1 Communication system include:

- (1) Communication between ODU and IDU;
- (2) Communication among IDUs;
- (3) Communication between IDU and wired controller;
- (4) Connection between IDU and light board receiver;
- (5) Graphics of general communication connection.

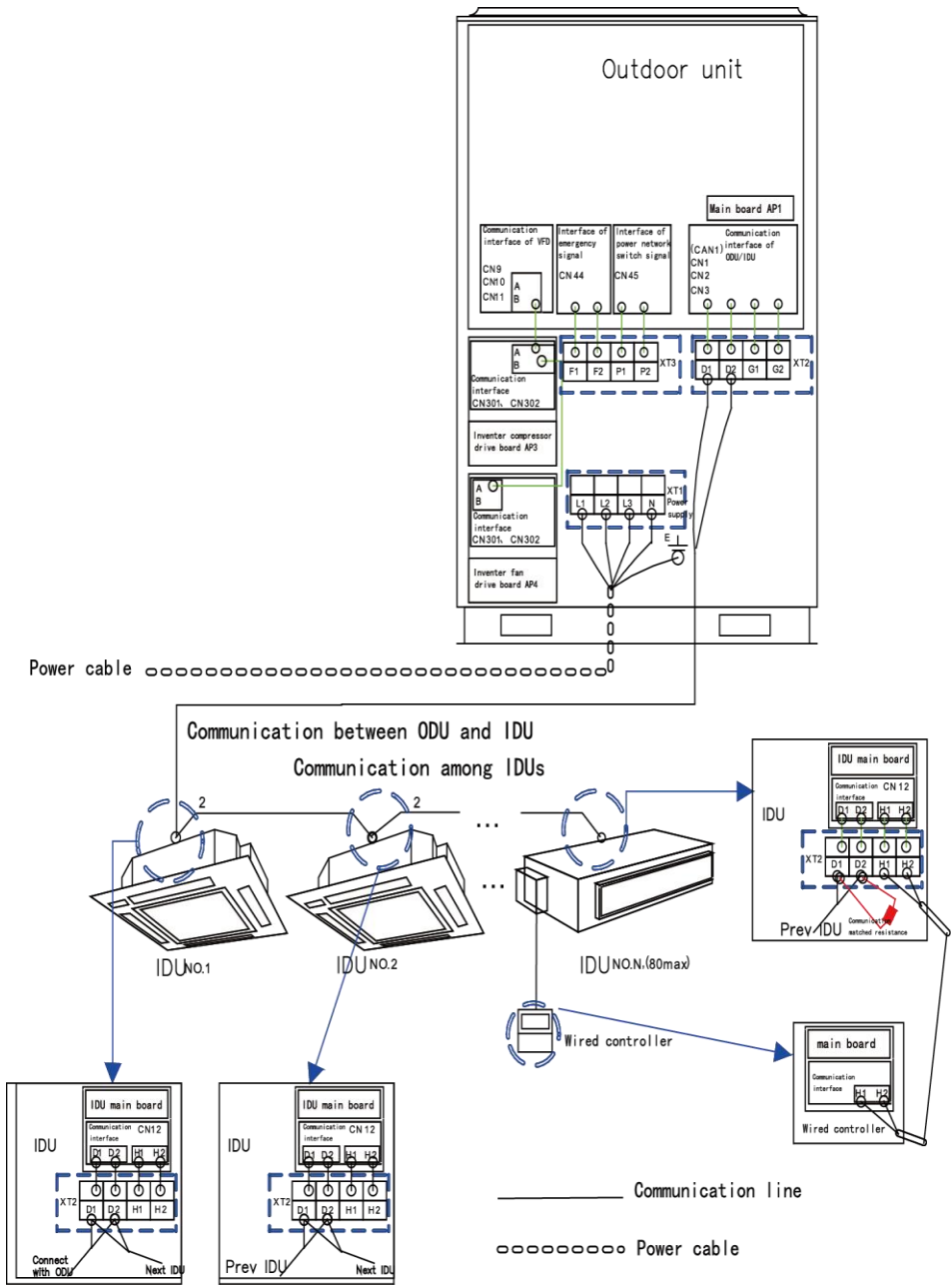

Fig.37

4.7.2 Communication mode

CAN bus mode is taken for communication between IDU and ODU and communication among IDUs.

4.7.3 Selection and connection mode of communication material

4.7.3.1 Select communication material

Note:

If air conditioners are installed at places where there's strong electromagnetic interference, the communication wire of IDU and wired controller must use shielded wire and the communication wire between IDU and IDU/ODU must use shielded twisted pair.

(1) Select communication wire between IDU and wired controller

Material type	Total length of communication line between IDU unit and wired controller L (m)	Wire size (mm ²)	Material standard	Remarks
Light/Ordinary polyvinyl chloride sheathed cord. (60227 IEC 52 /60227 IEC 53)	L≤250	2×0.75~2×1.25	IEC 60227-5:2007	1. Total length of communication line can't exceed 250m. 2. The cord shall be Circular cord (the cores shall be twisted together). 3. If unit is installed in places with intense magnetic field or strong interference, it is necessary to use shielded wire.

Graphic of connection between IDU and wired controller

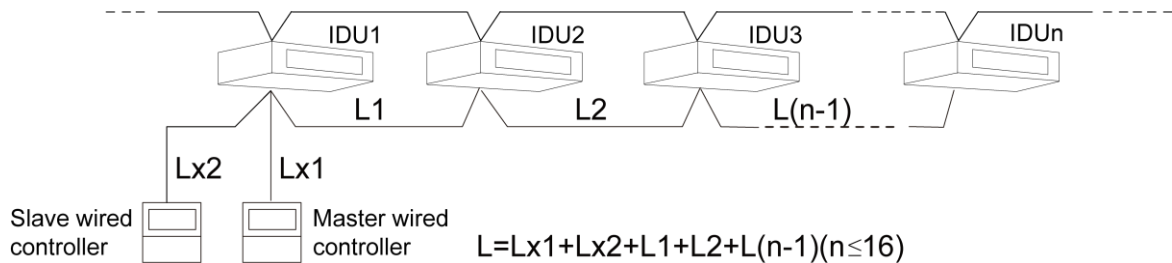

Fig.38

(2) Select communication wire between ODU and IDU

Material Type	Total Length L(m) of Communication Cable between IDU Unit and IDU (ODU) Unit	Wire size (mm ²)	Material Standard	Remarks
Light/Ordinary polyvinyl chloride sheathed cord. (60227 IEC 52 /60227 IEC 53)	L≤1000	≥2×0.75	IEC 60227-5:2007	1. If the wire diameter is enlarged to 2 × 1 mm ² , the total communication length can reach 1500m. 2. The cord shall be Circular cord (the cores shall be twisted together). 3. If unit is installed in places with intense magnetic field or strong interference, it is necessary to use shielded wire.

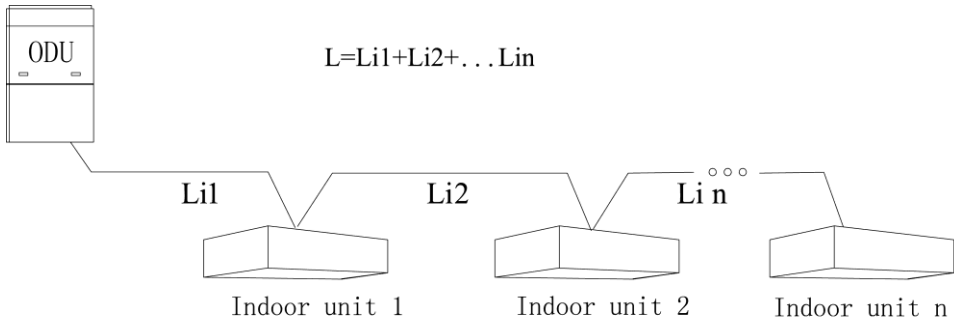

Fig.39

4.7.3.2 Connection mode of communication

(1) All communication wires must be connected in series rather than in star.

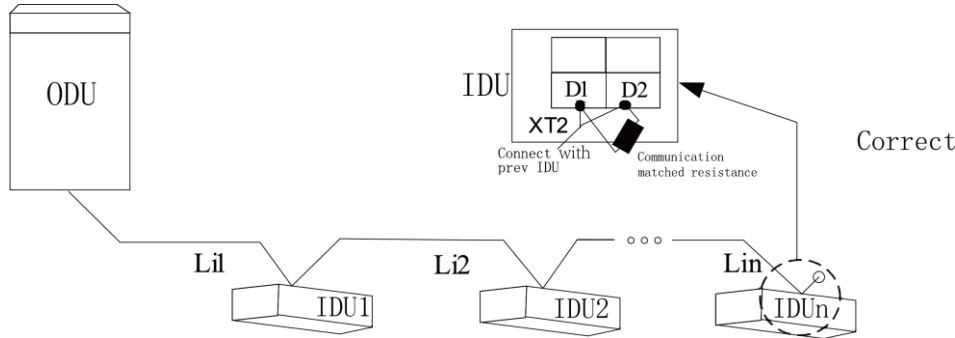

Fig.40

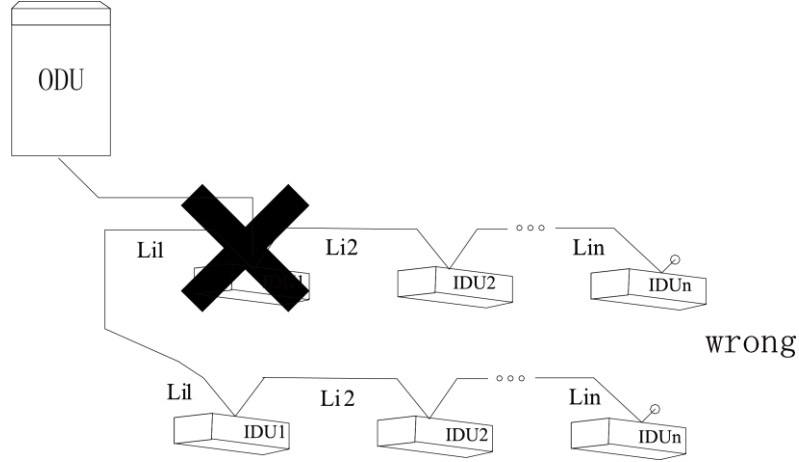

Fig.41

(2) All communication wires are connected by screws.

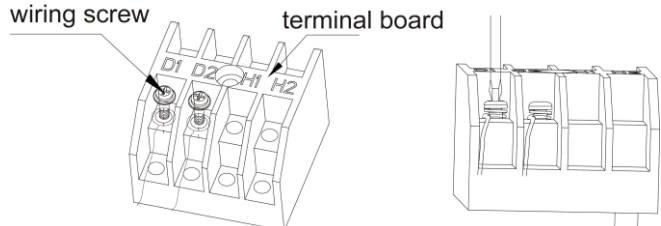

Fig.42

(3) If a single communication wire is not long enough and needs to be connected, the connected joint must be welded or pressure-welded. Do not simply twist the wires together.

4.7.4 Communication address

Auto addressing technology is adopted for IDU and ODU. No need to set address codes manually. Only the addresses of master unit and central control are needed to be set (address of central control is only needed when there are multiple refrigeration systems).

Note:

When installing remote monitor or central controller, displacement on indoor units' project codes must be made. Otherwise, there will be collision malfunction of the project codes. For detail operation methods, please refer to the Installation and Maintenance Manual.

4.8 Connection Method and Steps for System Communication

4.8.1 Communication connection between IDU and ODU

Note: The centralized controller can be installed when it is necessary.

Connect IDU and ODU via terminal D1/D2 of wiring board XT2. Below are the connection graphics of single unit and modular units:

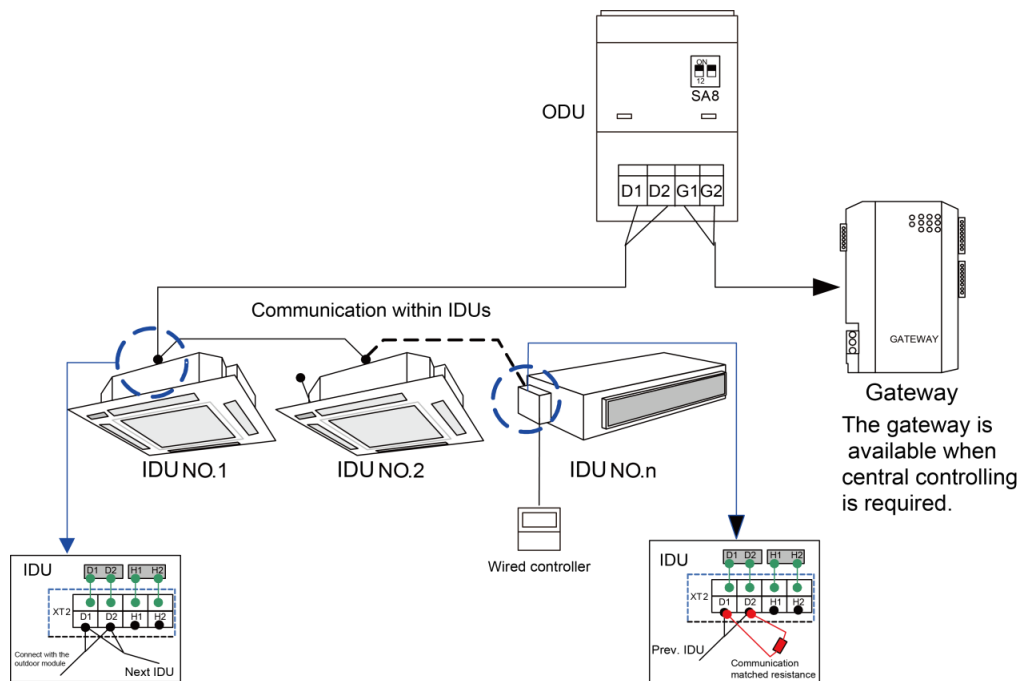

Fig.43 Connection of single unit

Note:

- ① Communication wire and power cord must be separated.
- ② Communication wire must be of proper length. Extension is not allowed.
- ③ IDUs must be connected in series. The last IDU must be connected with the communication matched resistance (supplied in the list of ODU spare parts).

4.8.2 Communication connection between IDU and wired controller

There are 4 kinds of connection between IDU and wired controller, as shown below:

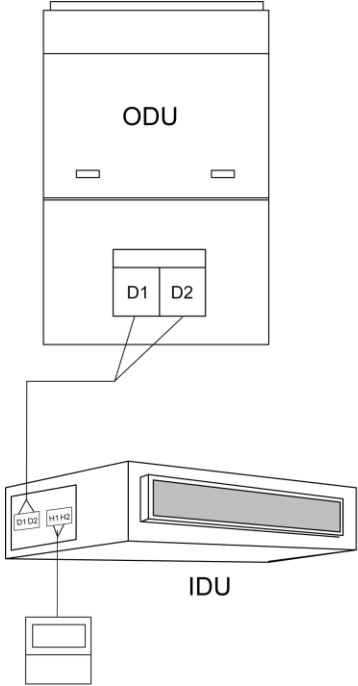

Fig.44 One wired controller controls one IDU

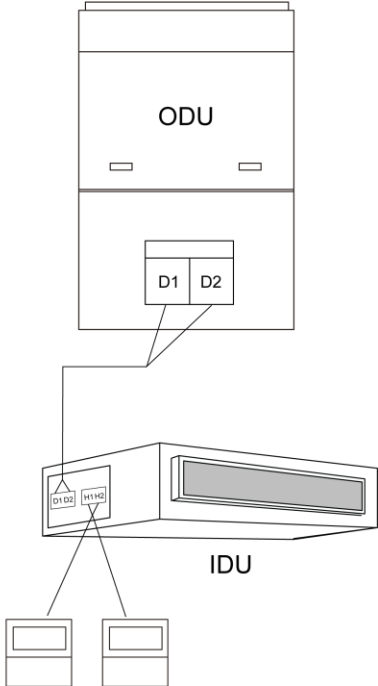

Fig.45 Two wired controllers control one IDU

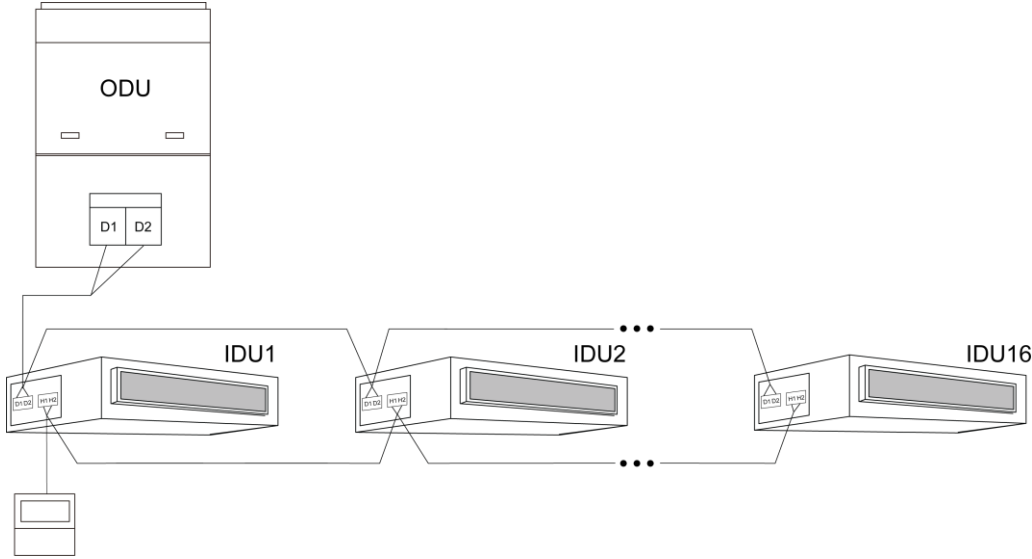

Fig.46 One wired controller controls multiple IDUs

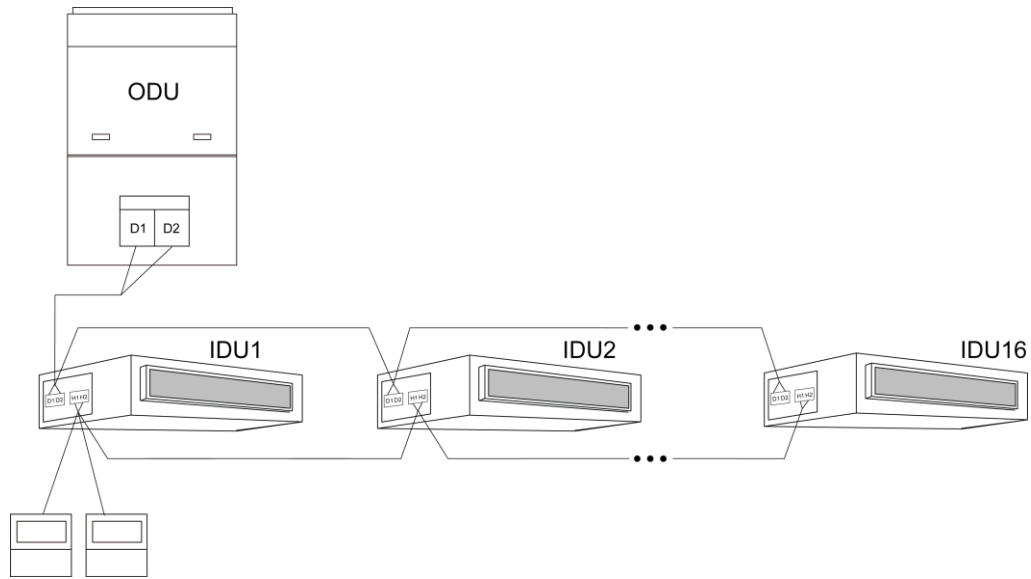

Fig.47 Two wired controllers control multiple IDUs

When two wired controllers control multiple IDUs, the wired controller can be connected to any one IDU, provided that the connected IDU is of the same series. Meanwhile, one and only one of the wired controllers must be set as a slave controller. At most 16 IDUs can be controlled by wired controllers and the connected IDUs shall be within a same IDU network.

No matter when unit is turned on or off, slave controller can be set.

How to set a slave controller:

- ① hold “function” button on the designated controller for 5s, and temperature zone displays C00. Continue holding “function” button for 5s and setting screen of controller parameter will come out. Default temperature zone displays P00.
- ② Press▲button or▼button to select parameter code P13. Press “mode” button to switch to setup of parameter values. Then the parameter value will blink. Press▲button or button▼ to select code 02. And then press “confirm/cancel” to finish setting.
- ③ Press “confirm/cancel” to return to the previous display until you exit from the setup of parameter values.

Below are user’s parameter settings:

Parameter code	Parameter name	Parameter scope	Default value	Remark
P13	Set up address for wired controller	01: master wired controller 02: slave wired controller	01	When 2 wired controllers control one or more IDUs, they shall have different addresses. Slave wired controller (02) can’t set up units’ parameters except its own address.

Note:

- ① The default factory setting of all wired controllers are in master wired controller status.
- ② Under parameter viewing status, FAN, TIMER, SLEEP and SWING buttons are invalid. Press “ON/OFF” button to go back to the home page, while not to turn on/off the unit.
- ③ Under parameter viewing status, the signal from remote controller is invalid.

4.8.3 Communication connection of central controlling units

Note: The centralized controller can be installed when it is necessary.

Port connection G1 and G2 on the wiring board XT2 of master unit among each multi VRF system. (see below)

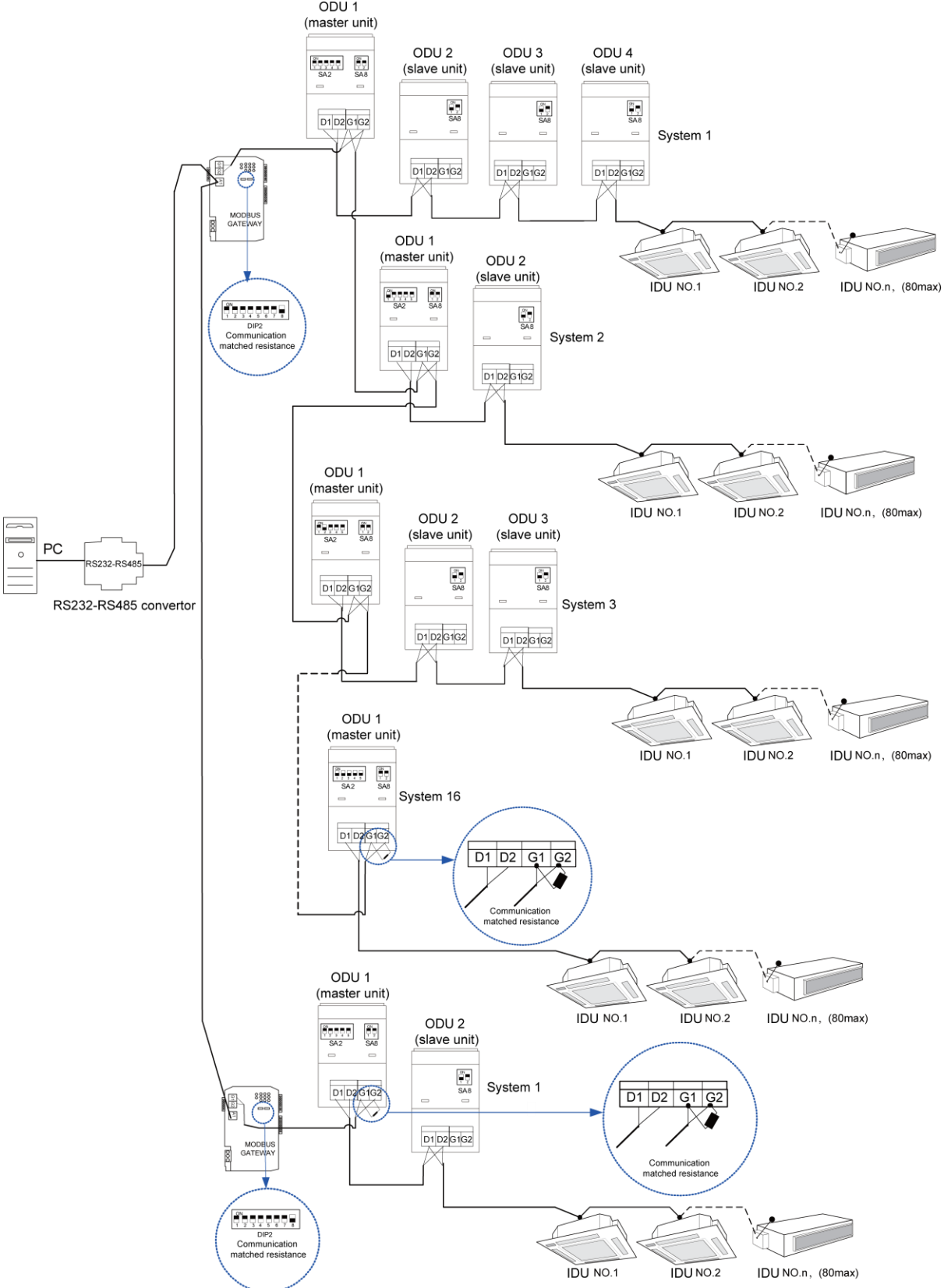

Fig.48

4.9 External Electrical Wiring Diagram

Each unit should be equipped with a circuit breaker for short circuit protection and exceptional overload protection. Besides, a main circuit breaker shall be prepared for IDUs and ODUs in order to connect or disconnect power of the entire system.

4.9.1 External wiring diagram of a single unit

Every unit should be equipped with a circuit breaker for short-circuit and overload protection. In general, circuit breaker is at OFF status. During operation, all indoor units and outdoor units belonging to the same system must be kept energized status. Otherwise, the unit can't operate normally.

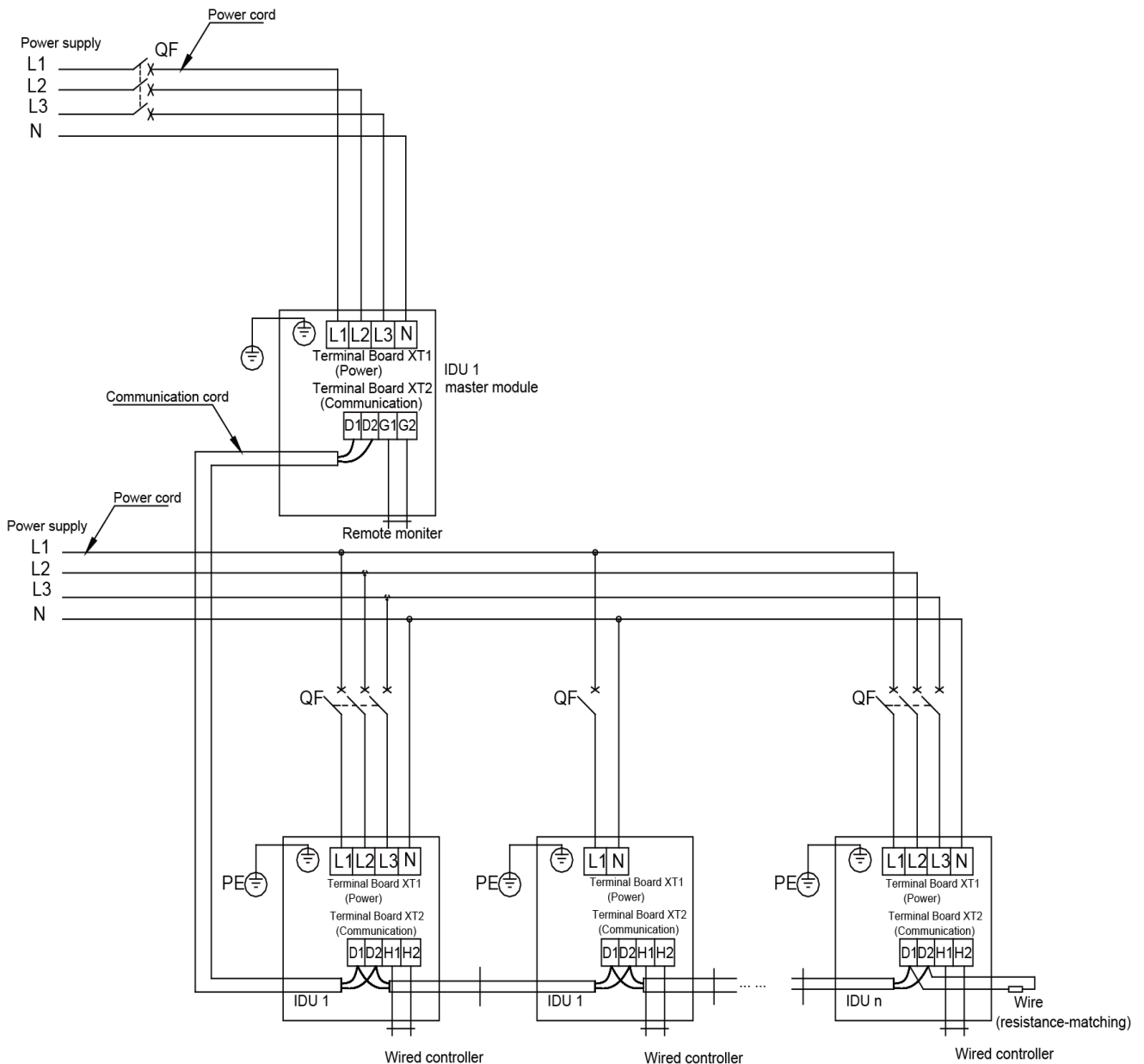

Fig.49

Note:

Maximum number of IDU is based upon ODU capacity. For details, please refer to the introduction of units' combination.

5 Check Items after Installation and Trial Run

5.1 Check Items after Installation

Check Items	Conditions Might Happen	Check
Has the unit been fixed firmly?	The unit may drop, shake or emit noise.	
Have you done the gas leakage test?	It may cause insufficient cooling/heating capacity.	
Is the unit get proper thermal insulation?	It may cause condensation and dripping.	
Does the unit drain well?	It may cause condensation and dripping.	
Is the voltage in accordance with the rated voltage specified on the nameplate?	It may cause malfunction or damage the part.	
Is the electric wiring and piping connection installed correctly and securely?	It may cause malfunction or damage the part.	
Has the unit been earthed securely?	It may cause electrical leakage.	
Is the power cord specified?	It may cause malfunction or damage the part.	
Has the inlet and outlet been blocked?	It may cause insufficient cooling/heating capacity.	
Has the pipe length and refrigerant charging amount been recorded?	The refrigerant charging amount is not accurate.	
Is the address code of outdoor modules correct?	The unit can not run normally. Communication malfunction might happen.	
Is the address code of indoor units and wired controller correct?	The unit can not run normally. Communication malfunction might happen.	
Has the communication line been connected correct?	The unit can not run normally. Communication malfunction might happen.	
Is the piping connection and valve status right?	The unit can not run normally.	
Whether phase sequence of external power cord is correct or not?	Operation failure occurs or unit is damaged.	
Whether the engineering piping work and wiring holes are sealed?	Maybe there are mice biting the wires, which is the cause of malfunction.	

5.2 Trial Run

Note: during debugging, one and only one module must be set as a master module. The modular number of outdoor unit is 1, which is set to the master module as well as master unit.

During debugging, one and only one IDU must be set as a master IDU.

When no special requirement is needed, no need to set other functions. Unit can operate according to ex-factory settings. When special requirement is needed, please read the Service Manual or Debugging and Maintenance Manual.

5.2.1 Preparation before trial run

- (1) The power supply should be turned on only after finishing all the installation.
- (2) All the control wires and cables are connected correctly and safely. Completely open the gas and liquid valves.
- (3) All the objects like metal filing, thrum and clip should be cleared after installation.
- (4) Check if the unit appearance and piping system is damaged or not due to transportation.
- (5) Check if the terminals of electrical element is loose and the phase sequence is correct or not.
- (6) Check the valve: For single-module unit, fully open the gas and liquid valve and close

oil balance valve; For dual/three module unit, fully open the gas, liquid valve and oil balance valve.

5.2.2 Trial run

5.2.2.1 Notices

- (1) Before test operation, make sure unit is power on and compressor has been preheated for more than 8 hours. Touch the unit to check whether it's normally preheated. Start test operation after unit is normally preheated, otherwise compressor might be damaged. Debugging must be performed by professional technicians or under the guide of professional technicians.

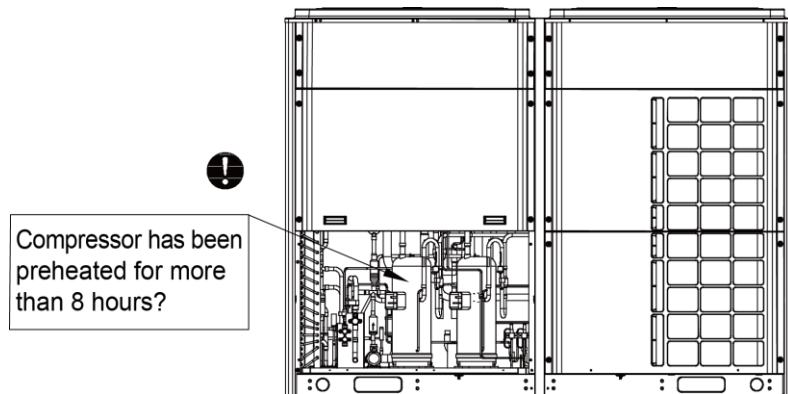

Fig.50

- (2) When debugging starts, system will operate according to the ambient temperature.
 - When outdoor temperature is above 20°C , debugging shall be in cooling mode.
 - When outdoor temperature is below 20°C , debugging shall be in heating mode.
- (3) Before debugging, confirm again whether the cut-off valve of each basic module is fully turned on.
- (4) During debugging, front panel of the outdoor unit must be fully closed; otherwise, debugging accuracy will be affected (see below).

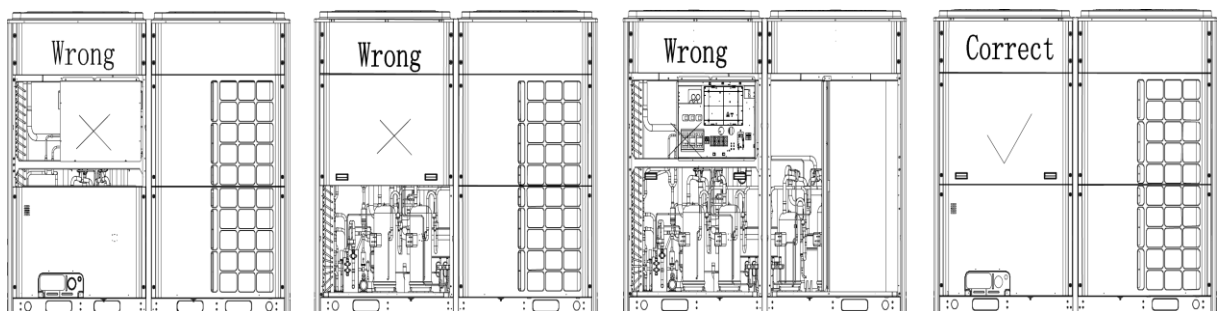

Fig.51

- (5) Before debugging, make sure the needed amount of refrigerant has been added to the pipe or at least 70% of the needed refrigerant has been added.

(6) Description of each stage of debugging progress:

Description of each stage of debugging progress							
—	Debugging code		Progress code		Status code		Meaning
progress	LED1		LED2		LED3		
	Code	Display status	code	Display status	Code	Display status	
01_Set up master unit	db	light	01	light	A0	light	System is not debugged.
	db	light	01	light	CC	light	System doesn't have master unit. Reset master unit.
	db	light	01	light	CF	light	More than 2 master units are set. Reset master unit.
	db	light	01	light	OC	light	Master unit is successfully set. Start next progress.

Description of each stage of debugging progress							
—	Debugging code		Progress code		Status code		Meaning
progress	LED1		LED2		LED3		
	Code	Display status	code	Display status	Code	Display status	
02_Allocate addresses	db	light	02	light	Ad	blink	System is allocating addresses.
	db	light	02	light	L7	blink	Master IDU is not set. Please set master IDU. If it's not set in 1min, system will set the master IDU randomly.
	db	light	02	light	OC	light	Allocation is finished. Start next progress.
03_Confirm the quantity of modules	db	light	03	light	01~04	blink	LED3 displays the quantity of modules. Confirm the number manually.
	db	light	03	light	OC	light	System has confirmed the quantity of modules. Start next progress.
04_Confirm the quantity of IDUs	db	light	04	light	01~80	blink	LED3 displays the quantity of IDUs. Confirm the number manually.
	db	light	04	light	OC	light	System has confirmed the quantity of IDUs. Start next progress.
05_Detect internal communication	db	light	05	light	C2	light	System detects "driven communication error between master unit and inverter compressor".
	db	light	05	light	C3	light	System detects "driven communication error between master unit and inverter fan".
	db	light	05	light	CH	light	IDU/ODU "high proportion of rated capacity".
	db	light	05	light	CL	light	IDU/ODU "low proportion of rated capacity".
	db	light	05	light	OC	light	Detection is finished. Start next progress.
06_Detect outdoor	db	light	06	light	Error code	light	System detects error in outdoor components.

Description of each stage of debugging progress							
—	Debugging code		Progress code		Status code		Meaning
progress	LED1		LED2		LED3		
	Code	Display status	code	Display status	Code	Display status	
components	db	light	06	light	OC	light	No error in outdoor components. Start next progress.
07_Detect indoor components	db	light	07	light	XXXX/Error code	light	System detects error in indoor components. XXXX is the project no. of the faulted IDU. 3s later, relevant error code is displayed. For example, IDU no. 100 has d5 error, then LED3 displays like this: 01 (2s later) 00 (2s later) d5, and repeat again.
	db	light	07	light	OC	light	No error in indoor components. Start next progress.
08_Confirm preheated compressor	db	light	08	light	U0	light	Preheat time for compressor is less than 8h.
	db	light	08	light	OC	light	Preheat time for compressor is 8h. Start next progress.
09_Refrigerant judgments before startup	db	light	09	light	U4	light	System refrigerant is not enough. System downtime equilibrium pressure is lower than 0.3MPa.
	db	light	09	light	OC	light	System refrigerant is normal. Start next progress.
10_Status judgments of outdoor valves before startup	db	light	10	light	ON	light	Outdoor valves are being turned on.
	db	light	10	light	U6	light	Outdoor valves are not fully turned on.
	db	light	10	light	OC	light	Outdoor valves are turned on normally.

Description of each stage of debugging progress							
—	Debugging code		Progress code		Status code		Meaning
progress	LED1		LED2		LED3		
	Code	Display status	code	Display status	Code	Display status	
11_Calculate refrigerant quantity manually	db	light	11	light	AE	light	Calculate the refrigerant quantity manually and confirm the perfusion status of refrigerant (the quantity of refrigerant added into the system must be recorded accurately).
12_Confirm debugging startup	db	light	12	light	AP	blink	Ready for units to start debugging.
	db	light	12	light	AE	light	Manual calculation of refrigerant quantity is set up.
13_	—	—	—	—	—	—	no meaning.
14_	—	—	—	—	—	—	no meaning.
15_Cooling debugging	db	light	15	light	AC	light	Debugging is enabled in cooling mode (debugging mode, auto-selected by system).
	db	light	15	light	Error code	light	Error occurs during debugging in

Description of each stage of debugging progress							
—	Debugging code		Progress code		Status code		Meaning
progress	LED1		LED2		LED3		
	Code	Display status	code	Display status	Code	Display status	
							cooling mode.
	db	light	15	light	J0	light	Error of other modules occurs during debugging in cooling mode.
	db	light	15	light	U9	light	Outdoor pipeline and valves are not normal.
	db	light	15	light	XXXX/U8	light	System detects error in indoor pipeline. XXXX is the project no. of the faulted IDU. 3s later, error code U8 is displayed. For example, IDU no. 100 has U8 error, then LED3 displays like this: 01 (2s later) 00 (2s later) U8, and repeat again.
16_Heating debugging	db	light	16	light	AH	light	Debugging is enabled in heating mode (debugging mode, auto-selected by system).
	db	light	16	light	Error code	light	Error occurs during debugging in heating mode.
	db	light	16	light	J0	light	Error of other modules occurs during debugging in heating mode.
	db	light	16	light	U9	light	Outdoor pipeline and valves are not normal.
	db	light	16	light	XXXX/U8	light	System detects error in indoor pipeline. XXXX is the project no. of the faulted IDU. 3s later, error code U8 is displayed. For example, IDU no. 100 has U8 error, then LED3 displays like this: 01 (2s later) 00 (2s later) U8, and repeat again.
17_Debugging finished	01~04	light	OF	light	OF	light	Debugging is finished. System is on standby condition. LED1 displays module address. LED2 and LED3 display "OF".

Note:

The modular number of outdoor unit is one, whose factory setting is the master module as well as the master unit.

5.2.2.2 Debugging operation mode

VRF system has two debugging modes: one is direct operation on main board of outdoor units while the other is PC operation via special software. In PC software debugging, indoor/outdoor parameters can be displayed and historical data can be recorded and inquired. (Operation details can be found in relevant instruction manuals)

(7) (1) Debugging through operation on main board of outdoor units

In this debugging mode, following debugging functions are included on the main board:

Step 1: front panel of the outdoor units must be fully closed. Open the debugging window

of outdoor unit;

Step 2: disconnect power for outdoor units. According to design requirements of external static pressure, set up corresponding static pressure mode for the units. Setting methods can be seen in Outdoor Fan Static Pressure Setup SA6_ESP_S;

Step 3: disconnect power for outdoor units and set one module as a master unit. Setting methods can be seen in Master Unit Setup SA8_MASTER_S;

Step 4: Connect power for all indoor units. Make sure all IDUs are power on. Then all outdoor modules will display “Debugging not enabled”;

Step 5: Hold SW7 button on the master module for at least 5s to enable debugging;

Step 6: Wait. Unit will then start progress 01 and 02;

In progress 02, if master IDU is not detected, then progress 02 will show the following errors:

LED1		LED2		LED3	
Function code	Display mode	Current progress	Display mode	Current status	Display mode
db	light	02	light	L7	blink

At this time, all buttons are ineffective. Set master IDU in 1min via debugging software. If master IDU is not set in 1min, system will set up a master IDU randomly. After that, system will start next progress.

Step 7: in progress 03, the quantity of modules needs to be confirmed manually. Main board of each module will display:

Progress	Debugging code		Progress code		Status code	
	LED1		LED2		LED3	
	Code	Display status	Code	Display status	Code	Display status
03_Quantity of modules	db	light	03	light	01	blink

If it displays “01”, press "SW7" on the master unit to confirm. The main board is displayed as follows and the unit automatically enters commissioning step 04.

Progress	Debugging code		Progress code		Status code	
	LED1		LED2		LED3	
	Code	Display status	Code	Display status	Code	Display status
03_Confirm the quantity of modules	db	light	03	light	OC	light

If the quantity displayed is different from actual quantity, then disconnect power and check whether communication wire among each module is correctly connected. Single outdoor refrigeration system can't be connected with other outdoors. After the check, start debugging again.

Step 8: in progress 04, the quantity of IDUs needs to be confirmed manually. Main board of each module will display:

Progress	Debugging code		Progress code		Status code	
	LED1		LED2		LED3	
	Code	Display status	Code	Display status	Code	Display status
04_Confirm the quantity of IDUs	db	Light	04	Light	Quantity of connected IDUs	blink

If the quantity displayed is the same with actual quantity, then press SW7 confirmation button on the master unit to confirm it. Unit will start next progress:

Progress	Debugging code		Progress code		Status code	
	LED1		LED2		LED3	
	Code	Display status	Code	Display status	Code	Display status
04_Confirm the quantity of IDUs	db	Light	04	Light	OC	Light

Step 9: progress 05 is “Detect internal communication”

If no error is detected, system will display as below and then start next progress.

progress	Debugging code		Progress code		Status code		Meaning
	LED1		LED2		LED3		
	Code	Display status	code	Display status	Code	Display status	
05_Detect internal communication	db	Light	05	Light	OC	Light	Detection is finished. Start next progress.

If error is detected, system will stay at current progress. Error has to be solved manually. Below are relevant errors:

progress	Debugging code		Progress code		Status code		Meaning
	LED1		LED2		LED3		
	Code	Display status	code	Display status	Code	Display status	
05_Detect internal communication	db	Light	05	Light	C2	Light	System detects “driven communication error between master unit and inverter compressor”.
	db	Light	05	Light	C3	Light	System detects “driven communication error between master unit and inverter fan”.
	db	Light	05	Light	CH	Light	IDU/ODU “high proportion of rated capacity”.
	db	Light	05	Light	CL	Light	IDU/ODU “low proportion of rated capacity”.

Elimination methods of above errors can be found in Troubleshooting.

Step 10: progress 06 is “Detect outdoor components”

If no error is detected, system will display as below and then start next progress.

—	Debugging code		Progress code		Status code		Meaning
progress	LED1		LED2		LED3		
	Code	Display status	code	Display status	Code	Display status	
06_Detect outdoor components	db	Light	06	Light	OC	Light	No error is detected in outdoor components. Start next progress.

If error is detected, system will stay at current progress. Error has to be solved manually.

Below is relevant error:

—	Debugging code		Progress code		Status code		Meaning
progress	LED1		LED2		LED3		
	Code	Display status	code	Display status	Code	Display status	
06_Detect outdoor components	db	Light	06	Light	Error code	Light	System detects error in outdoor components.

Elimination methods of above error can be found in Troubleshooting.

Step11: progress 07 is “Detect indoor components”

If no error is detected, system will display as below and then start next progress.

—	Debugging code		Progress code		Status code		Meaning
progress	LED1		LED2		LED3		
	Code	Display status	code	Display status	Code	Display status	
07_Detect indoor components	db	Light	07	Light	OC	Light	No error is detected in indoor components. Start next progress.

If error is detected, system will stay at current progress. Error has to be solved manually.

Below is relevant error:

—	Debugging code		Progress code		Status code		Meaning
progress	LED1		LED2		LED3		
	Code	Display status	code	Display status	Code	Display status	
07_Detect indoor components	db	Light	07	Light	XXXXor Error code	Light	System detects error in indoor components.

XXXX is the project no. of the faulted IDU. 3s later, relevant error code is displayed. For example, IDU no. 100 has d5 error, then LED3 displays like this: 01 (2s later) 00 (2s later) d5, and repeat again.

Elimination methods of above error can be found in Troubleshooting.

Step 12: progress 08 is “Confirm preheated compressor”

If more than 8h of preheat time is detected, system will display as below and start next progress.

—	Debugging code		Progress code		Status code		Meaning
progress	LED1		LED2		LED3		
	Code	Display status	code	Display status	Code	Display status	
08_Confirm preheated compressor	db	Light	08	Light	OC	Light	Preheat time for compressor is 8h. Start next progress.

If less than 8h of preheat time is detected, system will give error alarm and display as below. Then press SW7 confirmation button to skip the wait time and start next progress. But this will cause force start of the compressor, which may damage the compressor.

—	Debugging code		Progress code		Status code		Meaning
progress	LED1		LED2		LED3		
	Code	Display status	code	Display status	Code	Display status	
08_Confirm preheated compressor	db	Light	08	Light	UO	Light	Preheat time for compressor is less than 8h.

Step 13: progress 09 is “Refrigerant judgments before startup”

If the refrigerant quantity inside the system meets the requirement of operation startup, system will display as below and start next progress.

—	Debugging code		Progress code		Status code		Meaning
progress	LED1		LED2		LED3		
	Code	Display status	code	Display status	Code	Display status	
09_Refrigerant judgments before startup	db	Light	09	Light	OC	Light	System refrigerant is normal. Start next progress.

If there's no or not enough refrigerant in the system to meet the requirement of operation startup, system will display U4 “refrigerant shortage protection” and fails to start next progress. Then check if there's any leakage or add refrigerant inside until error eliminated.

—	Debugging code		Progress code		Status code		Meaning
progress	LED1		LED2		LED3		
	Code	Display status	code	Display status	Code	Display status	
09_Refrigerant judgments before startup	db	Light	09	Light	U4	Light	System refrigerant is not enough. System downtime equilibrium pressure is lower than 0.3MPa.

Step 14: progress 10 is “Status judgments of outdoor valves before startup”

If master unit displays below, status judgments are enabled.

—	Debugging code		Progress code		Status code		Meaning
progress	LED1		LED2		LED3		
	Code	Display status	code	Display status	Code	Display status	
10_Status judgments of outdoor valves before startup	db	Light	10	Light	ON	Light	Outdoor valves are being turned on.

If unit detects that valve status is not normal, it will display as below:

—	Debugging code		Progress code		Status code		Meaning
progress	LED1		LED2		LED3		
	Code	Display status	code	Display status	Code	Display status	
10_Status judgments of outdoor valves before startup	db	Light	10	Light	U6	Light	Outdoor valves are not fully turned on.

Then check the big and small valves whether they are fully turned on. After the check, press SW6 return button to restart the judgments.

If unit detects that valve status is normal, it will display as below and start next progress.

—	Debugging code		Progress code		Status code		Meaning
progress	LED1		LED2		LED3		
	Code	Display status	code	Display status	Code	Display status	
10_Status judgments of outdoor valves before startup	db	Light	10	Light	OC	Light	Outdoor valves are turned on normally.

Step 15: progress 11 is “Calculate refrigerant quantity manually”

No need to operate. System will start next progress.

Step 16: progress 12 is “Confirm debugging startup”

In order to make sure all preparation work is done before startup, this step is designed for user to confirm the startup again. Operate as below:

If master unit displays as below, system is waiting for confirmation signal.

—	Debugging code		Progress code		Status code		Meaning
progress	LED1		LED2		LED3		
	Code	Display status	code	Display status	Code	Display status	
12_Status judgments of outdoor valves before startup	db	Light	12	Light	AP	Blink	Ready for units to start debugging.

If it's confirmed, press SW7 confirmation button. Unit will display as below and start next progress.

—	Debugging code		Progress code		Status code		Meaning
progress	LED1		LED2		LED3		
	Code	Display status	code	Display status	Code	Display status	
12_Status judgments of outdoor valves before startup	db	Light	12	Light	AE	Light	Manual calculation of refrigerant quantity is set up.

Step 17: after unit is confirmed to start debugging, system select cooling/heating mode according to ambient temperature.

A. If cooling mode is selected, relevant display is as below:

—	Debugging code		Progress code		Status code		Meaning
progress	LED1		LED2		LED3		
	Code	Display status	code	Display status	Code	Display status	
15_Cooling debugging	db	Light	15	Light	AC	Light	Debugging is enabled in cooling mode (debugging mode, auto-selected by system).
	db	Light	15	Light	Error code	Light	Error occurs during debugging in cooling mode.
	db	Light	15	Light	J0	Light	Error of other modules occurs during debugging in cooling mode.
	db	Light	15	Light	U9	Light	Outdoor pipeline and valves are not normal.
	db	Light	15	Light	XXXX/U8	Light	System detects error in indoor pipeline. XXXX is the project no. of the faulted IDU. 3s later, error code U8 is displayed. For example, IDU no. 100 has U8 error, then LED3 displays like this: 01 (2s later) 00 (2s later) U8, and repeat again.

B. If heating mode is selected, relevant display is as below:

—	Debugging code		Progress code		Status code		Meaning
progress	LED1		LED2		LED3		
	Code	Display status	code	Display status	Code	Display status	
16_Heating debugging	db	Light	16	Light	AH	Light	Debugging is enabled in heating mode (debugging mode, auto-selected by system).
	db	Light	16	Light	Error code	Light	Error occurs during debugging in heating mode.
	db	Light	16	Light	J0	Light	Error of other modules occurs during debugging in heating mode.
	db	Light	16	Light	U9	Light	Outdoor pipeline and valves are not normal.

—	Debugging code		Progress code		Status code		Meaning
progress	LED1		LED2		LED3		
	Code	Display status	code	Display status	Code	Display status	
	db	Light	16	Light	XXXX/U8	Light	System detects error in indoor pipeline. XXXX is the project no. of the faulted IDU. 3s later, error code U8 is displayed. For example, IDU no. 100 has U8 error, then LED3 displays like this: 01 (2s later) 00 (2s later) U8, and repeat again.

Step 18: if there's no error during operation for about 40min, system will automatically confirm that debugging is finished and then stop. System resumes standby condition and displays as below:

—	Debugging code		Progress code		Status code		Meaning
progress	LED1		LED2		LED3		
	Code	Display status	code	Display status	Code	Display status	
17_Debugging finished	01-04	Light	OF	Light	OF	Light	Debugging is finished. System is on standby condition. LED1 displays module address. LED2 and LED3 display "OF".

Step 19: after debugging is finished, some functions can be set up according to project's actual needs. For specific details, please refer to System Functions Setup. If no special requirements, skip this step.

Step 20: deliver the product to user and inform user about usage precautions.

5.2.3 Appendix: judgment reference of normal operational parameters

Reference of Debug Parameters					
No.	Debug item	Parameter name	Unit	Reference	
1	System parameters	ODU	Outdoor ambient temp	℃	—
2			Discharge tube temp of inverter compressor	℃	●When system compressor starts up, temp of discharge tube or casing top in cooling mode is within 70~95℃ , and at least 10℃ higher than system high pressure saturation temp; Temp in heating mode is within 65℃ ~80℃ , and at least 10℃ higher than system high pressure saturation temp.
3			Casing top temp of inverter compressor	℃	
4			Discharge tube temp of Constant frequency compressor	℃	
5			Defrost temp 1	℃	●In cooling mode, defrost temp1 is 5~11℃ lower than system high pressure value; ●In heating mode, defrost temp1 is about 2℃ different from system low pressure value.
6			System high pressure	℃	●System's normal high pressure value is within 20℃ ~25℃ . According to the change in ambient temp and

Reference of Debug Parameters				
No.	Debug item	Parameter name	Unit	Reference
				system operational capacity, system's high pressure value is 10 ~40℃ higher than ambient temp The higher ambient temp is, the smaller temp difference is. ●When ambient temp is 25~35℃ , system's high pressure value in cooling mode is 44~53℃ . ●When ambient temp is -5~10℃ , system's high pressure value in heating mode is 40~52℃ .
7		System low pressure	℃	●When ambient temp is 25~35℃ , system's low pressure value in cooling mode is 0~8℃ . ●When ambient temp is -5~10℃ , system's low pressure value in heating mode is -15~5℃ .
8	System parameters	ODU	Opening angle of heating EXV	PLS ●In cooling mode, heating electronic expansion valve remains 480PLS. ●In heating mode, the opening angle of adjustable electronic expansion valve varies within 120~480PLS.
9			Operating freq. of inverter compressor	Hz Varies from 20Hz to 95Hz
10			Current of inverter compressor	A ●According to different operating freq. and different load, current will vary from 7A to 25A.
11			IPM temp of inverter compressor	℃ ●When ambient temp is lower than 35℃ , IPM temp is below 80℃ . Highest temp won't be above 95℃ .
12			Inverter compressor driven bus voltage	V ●Normal bus voltage is 1.414 times of power voltage. For example, if 3-phase power voltage is 390v, then the bus voltage after rectification is: 390v X 1.414=551v. It's normal if actual voltage varies 15v from the calculated voltage.
13	System parameters	ODU	Operating freq of fan motor 1	Hz Adjusts in 0~65Hz according to system pressure.
14			Current of fan motor 1	A
15			Operating freq of fan motor 2	Hz ●Adjusts in 0~65Hz according to system pressure.
16			Current of fan motor 2	A
17		IDU	Ambient temp of IDU	℃ —
18			Inlet tube temp of indoor heat exchanger	℃ ●According to different ambient temp, for a same IDU under cooling mode, inlet tube temp will be 1 ~7℃ lower than outlet tube temp.
19			Outlet tube temp of indoor heat exchanger	℃ ●For a same IDU under heating mode, inlet tube temp will be 10 ~20℃ lower than outlet tube temp.
20			Opening angle of indoor EXV	PLS Adjusts opening angle automatically in 200~2000PLS or 70~480PLS.
21	Communication parameter	Communication data	—	●Quantity of IDU and ODU detected by software is the same with actual quantity. No communication error.
22	Drainage system	—	—	●IDU can drain water out completely and smoothly. Condensate pipe has no backward slope of water. Water of ODU can be drained completely through drainage pipe. No water drop from unit base.

Reference of Debug Parameters				
No.	Debug item	Parameter name	Unit	Reference
23	Others	—	℃	•Compressor and indoor/outdoor fan motor has no strange noise. Unit operates normally.

6 Common Malfunction and Troubleshooting

Check the following items before contacting for repair.

Phenomenon	Reason	Measure
The unit doesn't run.	Without power supply	Connect to power supply
	Voltage is too low	Check if the voltage is within rating range
	Broken fuse or breaker trips off	Replace fuse or connect breaker
	Insufficient energy of remote controller	Replace new battery
	Remote controller is out of control scope	Control scope is within 8m
Unit runs but stop immediately	Air intake or outlet of indoor or outdoor unit is blocked	Remove obstruction
Abnormal cooling or heating	Air intake or outlet of indoor or outdoor unit is blocked	Remove obstruction
	Improper temperature setting	Adjust setting at wireless remote controller or wired controller
	Fan speed is set too low	Adjust setting at wireless remote controller or wired controller
	Wind direction is not correct	Adjust setting at wireless remote controller or wired controller
	Door or windows are opened	Close the door or windows
	Direct sunshine	Draw curtain or louver
	Too many people in the room	
	Too many heat resources in the room	Reduce heat resources
	Filter is blocked for dirt	Clean the filter

Note:

If problem can not be solved after checking the above items, please contact ASAMI service center and show phenomena and models.

Following circumstance are not malfunction.

“Malfunction”		Reason
Unit doesn't run	When unit is started immediately after it is just turned off	Overload protection switch makes it run after 3 minutes delay
	When power is turned on	Standby operating for about 1 minute
Mist comes from the unit	Under cooling	Indoor high humidity air is cooled rapidly
Noise is emitted	Slight cracking sound is heard when just turned on	It is noise when electronic expansion valve initialization
	There is consecutive sound when cooling	That's sound for gas refrigerant flowing in unit
	There is sound when unit starts or stops	That's sound for gas refrigerant stops to flow
	There is slight and consecutive sound when unit is running or after running	That's sound for operation of drainage system
	Cracking sound is heard when unit is operating and after operating	That's sound caused by expansion of panel and other parts due to temperature change

"Malfunction"		Reason
The unit blows out duct	When unit runs after no operation for a long period	Dust in indoor unit is blew out
The unit emits odor	Operating	The room odor absorbed by the unit is blew out again
Indoor unit still runs after switch off	After every indoor unit receive "stop" signal, fan will keep running	Indoor fan motor will keep running 20-70s so as to take good use of excess cooling and heating and prepare for next operation
Mode conflict	COOL or HEAT mode can not be operated	When the indoor operating mode conflicts with that of outdoor unit, indoor fault indicator will flash and conflict will be shown on the wired controller after 5 minutes. Indoor unit stops to run and meanwhile change outdoor operating mode as the same as that of indoor unit, then the unit will go back to normal. COOL mode doesn't conflict with DRY mode. FAN mode doesn't conflict with any mode.

7 Error Indication

Inquiry method of malfunction display: combine division number and content number to check the corresponding malfunction.

Indoor:

Error Code	Content	Error Code	Content
L0	Malfunction of IDU	d2	Malfunction of lower water temperature sensor of water tank
L1	Protection of indoor fan	d3	Malfunction of ambient temperature sensor
L2	Auxiliary heating protection	d4	Malfunction of entry-tube temperature sensor
L3	Water-full protection	d6	Malfunction of exit-tube temperature sensor
L4	Abnormal power supply for wired controller	d7	Malfunction of humidity sensor
L5	Freeze prevention protection	d8	Malfunction of water temperature sensor
L7	No main IDU	d9	Malfunction of jumper cap
L8	Power supply is insufficient	dA	Web address of IDU is abnormal
L9	For single control over multiple units, number of IDU is inconsistent	dH	PCB of wired controller is abnormal
LA	For single control over multiple units, IDU series is inconsistent	dC	Setting capacity of DIP switch code is abnormal
LH	Alarm due to bad air quality	dL	Malfunction of air outlet temperature sensor
LC	IDU is not matching with outdoor unit	dE	Malfunction of indoor CO ₂ sensor
LL	Malfunction of water flow switch	dF	Malfunction of upper water temperature sensor of water tank
LE	Rotation speed of EC DC water pump is abnormal	dJ	Malfunction of backwater temperature sensor
LF	Malfunction of shunt valve setting	dP	Malfunction of inlet tube temperature sensor of generator
LJ	Setting of functional DIP switch code is wrong	dU	Malfunction of drainage pipe temperature sensor of generator

Error Code	Content	Error Code	Content
LP	Zero-crossing malfunction of PG motor	db	Debugging status
LU	Indoor unit's branch is not inconsistent for one-to-more unit of heat recovery system	dd	Malfunction of solar power temperature sensor
d1	Indoor PCB is poor	dn	Malfunction of swing parts

Outdoor:

Error Code	Content	Error Code	Content
E0	Malfunction of ODU	FC	Current sensor of compressor 2 is abnormal
E1	High-pressure protection	FL	Current sensor of compressor 3 is abnormal
E2	Discharge low-temperature protection	FE	Current sensor of compressor 4 is abnormal
E3	Low-pressure protection	FF	Current sensor of compressor 5 is abnormal
E4	High discharge temperature protection of compressor	FJ	Current sensor of compressor 6 is abnormal
J0	Protection for other modules	FP	Malfunction of DC motor
J1	Over-current protection of compressor 1	FU	Malfunction of casing top temperature sensor of compressor 1
J2	Over-current protection of compressor 2	Fb	Malfunction of casing top temperature sensor of compressor 2
J3	Over-current protection of compressor 3	Fd	Malfunction of exit tube temperature sensor of mode exchanger
J4	Over-current protection of compressor 4	Fn	Malfunction of inlet tube temperature sensor of mode exchanger
J5	Over-current protection of compressor 5	b1	Malfunction of outdoor ambient temperature sensor
J6	Over-current protection for compressor 6	b2	Malfunction of defrosting temperature sensor 1
J7	Gas-mixing protection of 4-way valve	b3	Malfunction of defrosting temperature sensor 2
J8	High pressure ratio protection of system	b4	Malfunction of liquid temperature sensor of sub-cooler
J9	Low pressure ratio protection of system	b5	Malfunction of gas temperature sensor of sub-cooler
JA	Protection because of abnormal pressure	b6	Malfunction of inlet tube temperature sensor of vapor liquid separator
JC	Water flow switch protection	b7	Malfunction of exit tube temperature sensor of vapor liquid separator
JL	Protection because high pressure is too low	b8	Malfunction of outdoor humidity sensor
JE	Oil-return pipe is blocked	b9	Malfunction of gas temperature sensor of heat exchanger
JF	Oil-return pipe is leaking	bA	Malfunction of oil-return temperature sensor 1
P0	malfunction of driving board of compressor	bH	Clock of system is abnormal
P1	Driving board of compressor operates abnormally	bE	Malfunction of inlet tube temperature sensor of condenser
P2	Voltage protection of driving board power of compressor	bF	Malfunction of outlet tube temperature sensor of condenser
P3	Reset protection of driving module of compressor	bJ	High-pressure sensor and low-pressure sensor are connected

Error Code	Content	Error Code	Content
			reversely
P4	Drive PFC protection of compressor	bP	Malfunction of temperature sensor of oil-return 2
P5	Over-current protection of inverter compressor	bU	Malfunction of temperature sensor of oil return 3
P6	Drive IPM module protection of compressor	bb	Malfunction of temperature sensor of oil return 4
P7	Malfunction of drive temperature sensor of compressor	H0	Malfunction of driving board of fan
P8	Drive IPM high temperature protection of compressor	H1	Driving board of fan operates abnormally
P9	Desynchronizing protection of inverter compressor	H2	Voltage protection of driving board power of fan
PA	Malfunction of drive storage chip of compressor	H3	Reset protection of driving module of fan
PH	High-voltage protection of compressor's drive DC bus bar	H4	Drive PFC protection of fan
PC	Malfunction of current detection circuit drive of compressor	H5	Over-current protection of inverter fan
PL	Low voltage protection for DC bus bar of drive of compressor	H6	Drive IPM module protection of fan
PE	Phase-lacking of inverter compressor	H7	Malfunction of drive temperature sensor of fan
PF	Malfunction of charging loop of driven of compressor	H8	Drive IPM high temperature protection of fan
PJ	Failure startup of inverter compressor	H9	Desynchronizing protection of inverter fan
PP	AC current protection of inverter compressor	HA	Malfunction of drive storage chip of inverter outdoor fan
PU	AC input voltage of drive of inverter compressor	HH	High-voltage protection of fan's drive DC bus bar
F0	Main board of ODU is poor	HC	Malfunction of current detection circuit of fan drive
F1	Malfunction of high-pressure sensor	HL	Low voltage protection of bus bar of fan drive
F3	Malfunction of low-pressure sensor	HE	Phase-lacking of inverter fan
F5	Malfunction of discharge temperature sensor of compressor 1	HF	Malfunction of charging loop of fan drive
F6	Malfunction of exit-tube temperature sensor	HJ	Failure startup of inverter fan
F7	Malfunction of humidity sensor	HP	AC current protection of inverter fan
F8	Malfunction of water temperature sensor	HU	AC input voltage of drive of inverter fan
F9	Malfunction of jumper cap	HJ	Failure startup of inverter fan
FA	Web address of IDU is abnormal	HP	AC current protection of inverter fan
FH	Current sensor of compressor 1 is abnormal	HU	AC input voltage of drive of inverter fan

Debugging:

Error Code	Content	Error Code	Content
U0	Preheat time of compressor is insufficient	C6	Alarm because ODU quantity is inconsistent
U2	Wrong setting of ODU's capacity code/jumper cap	C7	Abnormal communication of converter
U3	Power supply phase sequence protection	C8	Emergency status of compressor
U4	Refrigerant-lacking protection	C9	Emergency status of fan
U5	Wrong address for driving board of compressor	CA	Emergency status of module
U6	Alarm because valve is abnormal	CH	Rated capacity is too high
U8	Malfunction of pipeline for IDU	CC	No main unit
U9	Malfunction of pipeline for ODU	CL	The matching ratio of rated capacity for IDU and ODU is too low
UC	Setting of main IDU is succeeded	CE	Communication malfunction between mode exchanger and IDU
UL	Emergency operation DIP switch code of compressor is wrong	CF	Malfunction of multiple main control units
UE	Charging of refrigerant is invalid	CJ	Address DIP switch code of system is shocking
UF	Identification malfunction of IDU of mode exchanger	CP	Malfunction of multiple wired controller
C0	Communication malfunction between IDU, ODU and IDU's wired controller	CU	Communication malfunction between IDU and the receiving lamp
C1	Communication malfunction between main control and DC-DC controller	Cb	Overflow distribution of IP address
C2	Communication malfunction between main control and inverter compressor driver	Cd	Communication malfunction between mode exchanger and ODU
C3	Communication malfunction between main control and inverter fan driver	Cn	Malfunction of network for IDU and ODU of mode exchanger
C4	Malfunction of lack of IDU	Cy	Communication malfunction of mode exchanger
C5	Alarm because project code of IDU is inconsistent		

Status:

Error Code	Content	Error Code	Content
A0	Unit waiting for debugging	Ay	Shielding status
A2	Refrigerant recovery operation of after-sales	n0	SE operation setting of system
A3	Defrosting	n3	Compulsory defrosting
A4	Oil-return	n4	Limit setting for max. capacity/output capacity
A6	Heat pump function setting	n5	Compulsory excursion of engineering code of IDU
A7	Quiet mode setting	n6	Inquiry of malfunction
A8	Vacuum pump mode	n7	Inquiry of parameters
AH	Heating	n8	Inquiry of project code of IDU
AC	Cooling	n9	Check quantity of IDU on line
AL	Charge refrigerant automatically	nA	Heat pump unit
AE	Charge refrigerant manually	nH	Heating only unit
AF	Fan	nC	Cooling only unit

Error Code	Content	Error Code	Content
AJ	Cleaning reminding of filter	nE	Negative code
AP	Debugging confirmation when starting up the unit	nF	Fan model
AU	Long-distance emergency stop	nJ	High temperature prevention when heating
Ab	Emergency stop of operation	nU	Eliminate the long-distance shielding command of IDU
Ad	Limit operation	nb	Bar code inquiry
An	Child lock status	nn	Length modification of connection pipe of ODU

8 Maintenance and Care

Regular check, Maintenance and care by professional personnel, which will prolong the unit life span. Disconnect the power supply before cleaning and maintenance.

8.1 Outdoor Heat Exchanger

Outdoor heat exchanger is required to be cleaned once every two months. Use vacuum cleaner with nylon brush to clean up dust and sundries on the surface of heat exchanger. Blow away dust by compressed air if it is available. Never use water to wash the heat exchanger.

8.2 Drain Pipe

Regularly check if the drain pipe is clogged in order to drain condensate smoothly.

8.3 Notice before Seasonal Use

- (1) Check if the inlet/outlet of the indoor/outdoor unit is clogged.
- (2) Check if the ground wire is earthed reliably.
- (3) Check if battery of remote wireless controller has been replaced.
- (4) Check if the filter screen has been set soundly.
- (5) After long period of shutdown, open the main power switch 8 hours before reoperating the unit so as to preheat the compressor crankcase.
- (6) Check if the outdoor unit is installed firmly. If there is something abnormal, please contact the ASAMI appointed service center.

8.4 Maintenance after Seasonal Use

- (1) Cut off main power supply of the unit.
- (2) Clean filter screen and indoor and outdoor units.
- (3) Clean the dust and sundries on the indoor and outdoor units.
- (4) In the event of rusting, use the anti-rust paint to stop spreading of rust.

8.5 Parts Replacement

Purchase parts from ASAMI appointed service center or dealer if necessary.

Note:

During airtight and leakage test, never mix oxygen, ethyne and other dangerous gas into refrigeration circuit. In case of hazard, it's better to use nitrogen or refrigerant to accomplish

such test.

9 After-sales Service

In case the air-conditioning unit you bought has any quality problem or you have any inquiry, please contact the local after-sales service agency designated by ASAMI.

Warranty should meet the following requirements:

- (1) First run of the unit should be operated by professional personnel from ASAMI appointed service center.
- (2) Only ASAMI manufactured accessories can be used on the machine.
- (3) All the instructions listed in this manual should be followed.
- (4) Warranty will be automatically invalid if fails to obey any item mentioned above.

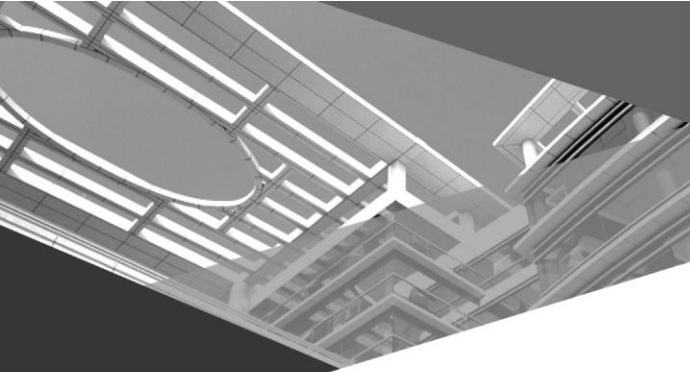

66129935547