



D.C. Inverter Multi VRF Modular

Owner's Manual Air Conditioners

Models: AMV5-O224
AMV5-O280
AMV5-O335
AMV5-O400
AMV5-O450
AMV5-O504



AMV5-O2460

● Thank you for choosing Air Conditioners, please read this owner's manual carefully before operation and retain it for future reference.

Preface

ASAMI DC Inverter Multi VRF System, with the most advanced technologies in the world, uses eco-friendly refrigerant R410A as its cooling medium. For correct installation and operation, please read this manual carefully. Before reading the manual, please note that:

- (1) For safety operation, please strictly follow the instructions in this manual.
- (2) During operation, the gross rated capacity of working IDU should be within the gross rated capacity of ODU. Otherwise, IDU's cooling/heating performance will be reduced.
- (3) This manual must be in the hands of direct operators or maintenance men.
- (4) In case of malfunction and operation failure, please examine the following items and contact our authorized service centers as soon as possible.
 - 1) Nameplate (model, cooling capacity, product code, ex-factory date).
 - 2) Malfunction status (detail description of conditions before and after malfunction occurs)
- (6) All units have been strictly tested and proved to be qualified before ex-factory. To avoid unit damage or even operation failure which may be caused by improper disassembly, please do not disassemble units by yourself. If disassembly is needed, please contact our authorized serve centers for help.
- (7) All graphics and information in this manual are only for reference. Manufacturer reserves the right for changes in terms of sales or production at any time and without prior notice.

This appliance can be used by children aged from 8 years and above and persons with reduced physical, sensory or mental capabilities or lack of experience and knowledge if they have been given supervision or instruction concerning use of the appliance in a safe way and understand the hazards involved. Children shall not play with the appliance. Cleaning and user maintenance shall not be made by children without supervision.

DISPOSAL: Donot dispose this product as unsorted municipal waste. Collection of such waste separately for special treatment is necessary.













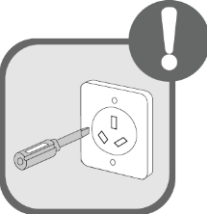

Contents

1 Safety Precautions	1
2 Product Introduction	3
2.1 Names of Main Parts.....	3
2.2 Combinations of Outdoor Units.....	4
2.3 Combinations of Indoor and Outdoor Units	5
2.4 The Range of Production Working Temperature	6
3 Preparation before Installation	6
3.1 Standard Parts	6
3.2 Installation Site.....	7
3.3 Piping Work Requirements	11
4 Installation Instruction.....	12
4.1 Physical Dimension of the Outdoor Unit and Mounting Hole	12
4.2 Connection Pipe.....	14
4.3 Installation of the Connection Pipe	26
4.4 Air Purging and Refrigerant Charge.....	29
4.5 Electric Wiring	31
4.6 System Communication	36
4.7 Connection Method and Steps for System Communication	40
4.8 External Electrical Wiring Diagram	45
5 Check Items after Installation and Trial Run	47
5.1 Check Items after Installation.....	47
5.2 Trial Run.....	47
6 Common Malfunction and Troubleshooting	59
7 Error Indication	61
8 Maintenance and Care	63
8.1 Outdoor Heat Exchanger	63
8.2 Drain Pipe	63
8.3 Notice before Seasonal Use	63
8.4 Maintenance after Seasonal Use.....	63
8.5 Parts Replacement.....	64
9 After-sales Service	64

1 Safety Precautions

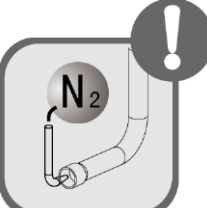
 means items that must be forbidden! Otherwise, it may lead to personal injury or death or serious damage.

 refers to things that must be followed. Incorrect operation may cause personal injury or death.

	<p>Follow this instruction to complete the installation work. Please carefully read this manual before unit startup and service.</p>		<p>Installation should be conducted by dealer or qualified personnel. Please do not attempt to install the unit by yourself. Improper handling may result in water leakage, electric shock or fire disaster etc.</p>
	<p>Before installation, please check if the power supply is in accordance with the requirements specified on the nameplate. And also take care of the power safety.</p>		<p>Make sure the unit can be earthed properly and soundly after plugging into the socket so as to avoid electric shock. Please do not connect the ground wire to gas pipe, water pipe, lightning rod or telephone line.</p>
	<p>Be sure to use the exclusive accessory and part to prevent the water leakage, electric shock and fire accidents.</p>		<p>If refrigerant leakage happens during installation, please ventilate immediately. Poisonous gas will emerge if the refrigerant gas meets fire.</p>
	<p>Wire size of power cord should be large enough. The damaged power cord and connection wire should be replaced by exclusive cable.</p>		<p>After connecting the power cord, please fix the electric box cover properly in order to avoid accident.</p>
	<p>Never fail to comply with the nitrogen charge requirements. Charge nitrogen when welding pipes.</p>		<p>Never short-circuit or cancel the pressure switch to prevent unit damage.</p>
	<p>Please firstly connect the wired controller before energization, otherwise wired controller can not be used.</p>		<p>Before using the unit, please check if the piping and wiring are correct to avoid water leakage, refrigerant leakage, electric shock, or fire etc.</p>

	<p>Do not insert fingers or objects into air outlet/inlet grille.</p>		<p>Open the door and window and keep good ventilation in the room to avoid oxygen deficit when the gas/oil supplied heating equipment is used.</p>
	<p>Never start up or shut off the air conditioner by means of directly plug or unplug the power cord.</p>		<p>Turn off the unit after it runs at least five minutes; otherwise it will influence oil return of the compressor.</p>
	<p>Do not allow children operate this unit.</p>		<p>Do not operate this unit with wet hands.</p>
	<p>Turn off the unit or cut off the power supply before cleaning the unit, otherwise electric shock or injury may happen.</p>		<p>Never spray or flush water towards unit, otherwise malfunction or electric shock may happen.</p>
	<p>Do not expose the unit to the moist or corrosive circumstances.</p>		<p>Electrify the unit 8 hours before operation. Please switch on for 8 hours before operation. Do not cut off the power when 24 hours short-time halting (to protect the compressor).</p>
	<p>Volatile liquid, such as diluent or gas will damage the unit appearance. Only use soft cloth with a little neutral detergent to clean the outer casing of unit.</p>		<p>Under cooling mode, please don't set the room temperature too low and keep the temperature difference between indoor and outdoor unit within 5.</p>
	<p>If anything abnormal happens (such as burning smell), please power off the unit and cut off the main power supply, and then immediately contact ASAMI appointed service center. If abnormality keeps going, the unit might be damaged and lead to electric shock or fire.</p>		<p>User is not allowed to repair the unit. Fault service may cause electric shock or fire accidents. Please contact ASAMI appointed service center for help.</p>

ASAMI will not assume responsibility of personal injury or equipment damage caused by

improper installation and commission, unnecessary service and incapable of following the rules and instructions listed in this manual.

2 Product Introduction

ASAMI Multi VRF Modular System adopts inverter compressor technology. According to change the displacement of compressor, stepless capacity regulation within range of 10%-100% can be realized. Various product lineup is provided with capacity range from 22.4kW to 246kW, which can be widely used in working area and especially applicable to the place with variable load change. ASAMI air conditioner is absolutely your best choice.

2.1 Names of Main Parts

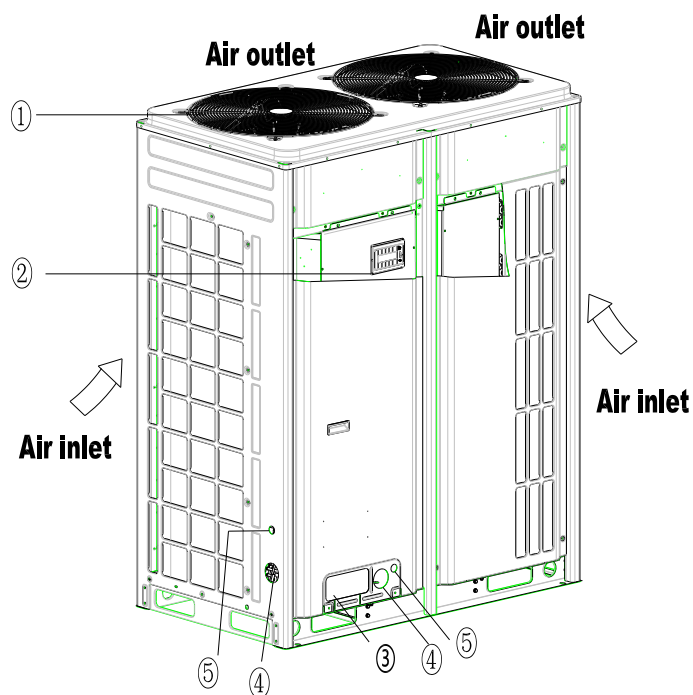
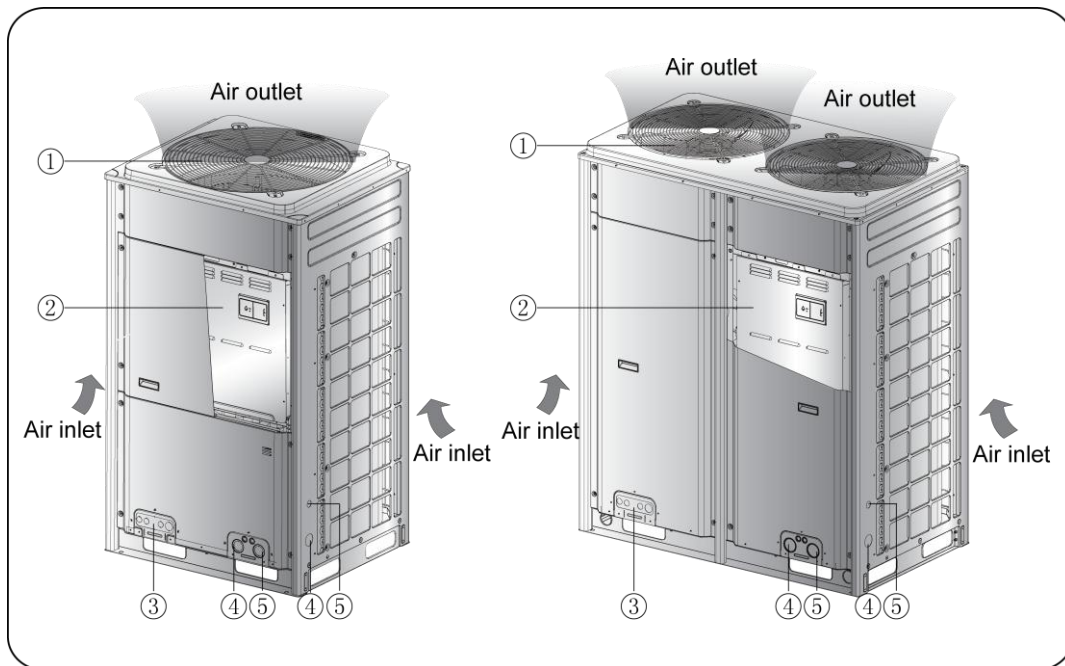

Fig.1

NO.	①	②	③	④	⑤
Name	Fan, Motor	Electric Box Assembly	Valve interface	Power cord through-hole	Communication code through-hole

2.2 Combinations of Outdoor Units

Model(Single)	AMV5-O680	AMV5-O730	AMV5-O785	AMV5-O850
Model(Combined)	AMV5-O280 +AMV5-O400	AMV5-O280 + AMV5-O450	AMV5-O280 + AMV5-O504	AMV5-O280 + AMV5-O560

Model(Single)	AMV5-O900	AMV5-O950	AMV5-O1010	AMV5-O1065
Model(Combined)	AMV5-O280 + AMV5-O615	AMV5-O335 + AMV5-O615	AMV5-O400 +AMV5-O615	AMV5-O450 + AMV5-O615

Model(Single)	AMV5-O1130	AMV5-O1180	AMV5-O1235	AMV5-O300
Model(Combined)	AMV5-O504 + AMV5-O615	AMV5-O560 + AMV5-O615	AMV5-O615 + AMV5-O615	AMV5-O280 + AMV5-O450 + AMV5-O560

Model(Single)	AMV5-O1350	AMV5-O1405	AMV5-O1456	AMV5-O1512
Model(Combined)	AMV5-O280 + AMV5-O450 + AMV5-O615	AMV5-O335 + AMV5-O450 + AMV5-O615	AMV5-O280 + AMV5-O560 + AMV5-O615	AMV5-O280 + AMV5-O615 + AMV5-O615

Model(Single)	AMV5-O1570	AMV5-O1650	AMV5-O1700	AMV5-O1750
Model(Combined)	AMV5-O335 + AMV5-O615 + AMV5-O615	AMV5-O400 + AMV5-O615 + AMV5-O615	AMV5-O450 + AMV5-O615 + AMV5-O615	AMV5-O504 + AMV5-O615 + AMV5-O615

Model(Single)	AMV5-O1800	AMV5-O1845	AMV5-O1908	AMV5-O1962
Model(Combined)	AMV5-O560 + AMV5-O615 + AMV5-O615	AMV5-O615 +AMV5-O615 +AMV5-O615	AMV5-O280 +AMV5-O450 +AMV5-O560 +AMV5-O615	AMV5-O280 +AMV5-O504 +AMV5-O560 +AMV5-O615

Model(Single)	AMV5-O2016	AMV5-O2072	AMV5-O2128	AMV5-O2184
Model(Combined)	AMV5-O280 +AMV5-O560 +AMV5-O560 +AMV5-O615	AMV5-O280 +AMV5-O560 +AMV5-O615 +AMV5-O615	AMV5-O280 +AMV5-O615 +AMV5-O615 +AMV5-O615	AMV5-O335 +AMV5-O615 +AMV5-O615 +AMV5-O615

Model(Single)	AMV5-O2240	AMV5-O2295	AMV5-O2350	AMV5-O2405
Model(Combined)	AMV5-O400 +AMV5-O615 +AMV5-O615 +AMV5-O615	AMV5-O450 +AMV5-O615 +AMV5-O615 +AMV5-O615	AMV5-O504 +AMV5-O615 +AMV5-O615 +AMV5-O615	AMV5-O560 +AMV5-O615 +AMV5-O615 +AMV5-O615

Model(Single)	AMV5-O2460
Model(Combined)	AMV5-O615 +AMV5-O615 +AMV5-O615 +AMV5-O615

2.3 Combinations of Indoor and Outdoor Units

(1) The following table indicates the number of IDU for ODU

ODU model	Max number of connectable IDU (unit)
AMV5-O224	13
AMV5-O280	16
AMV5-O335	19
AMV5-O400	23
AMV5-O450	26
AMV5-O504	29
AMV5-O560	33
AMV5-O615	36
AMV5-O680	39
AMV5-O730	43
AMV5-O785	46
AMV5-O850	50
AMV5-O900	53
AMV5-O960	56
AMV5-O1010	59
AMV5-O1065	63
AMV5-O1130	64
AMV5-O1180	64
AMV5-O1235	64
AMV5-O1300	64
AMV5-O1350	64
AMV5-O1410	66
AMV5-O1460	69
AMV5-O1515	71
AMV5-O1580	74
AMV5-O1630	77
AMV5-O1685	80
AMV5-O1750	80
AMV5-O1800	80
AMV5-O1845	80
AMV5-O1908	80
AMV5-O1962	80
AMV5-O2016	80
AMV5-O2072	80
AMV5-O2128	80
AMV5-O2184	80
AMV5-O2240	80

AMV5-O2295	80
AMV5-O2350	80
AMV5-O2405	80
AMV5-O2460	80

The total capacity of indoor units should be within 50%~135% of that of outdoor units.

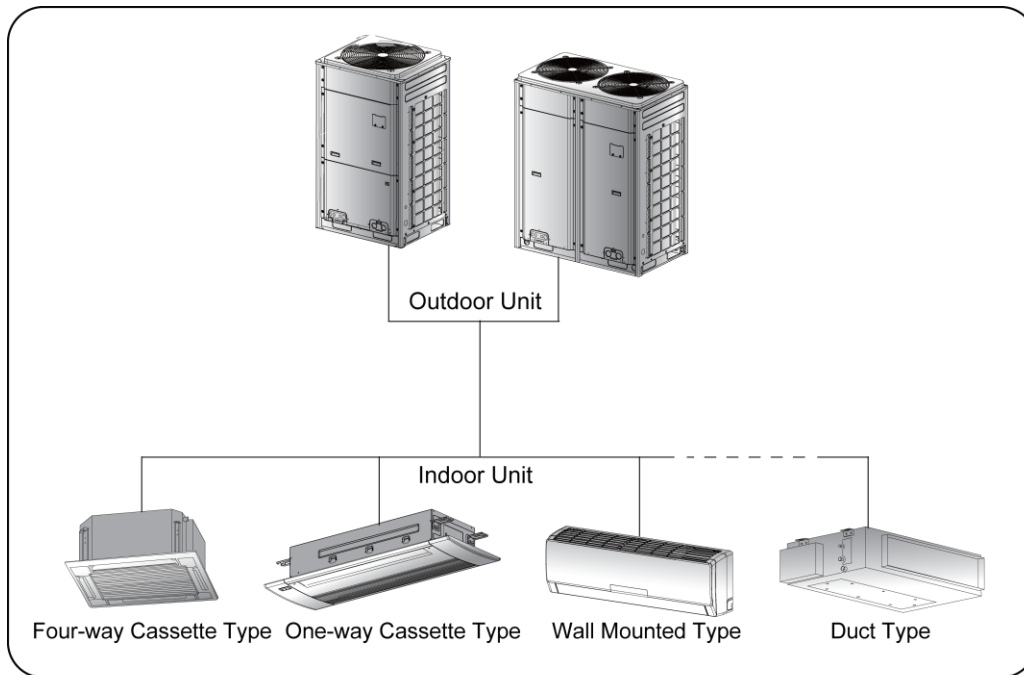

Fig.2

Fig.2 is the combination view of the ODU of Modular DC Inverter Multi VRF System and the IDU of Multi VRF System. IDU can be cassette type, one-way cassette type, wall-mounted type, duct type, etc. When any one IDU receives operation signal, ODU will start to work according to the capacity; when all IDUs stop, ODU will also stop.

2.4 The Range of Production Working Temperature

Cooling	Ambient temperature: -5~52
Heating	Ambient temperature: -20~24

When the indoor units are all VRF fresh air processor, the unit operating range is as follows:

Cooling	Ambient temperature: 16°C~45°C
Heating	Ambient temperature: -7°C~16°C



If the temperature is beyond the range, the safety protection measure of the unit may take effect, and the air conditioning unit will stop.

3 Preparation before Installation

Note: The picture is only used for reference and the actual product prevails. Unit: mm.

3.1 Standard Parts

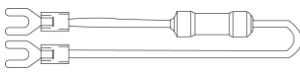







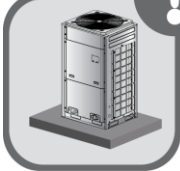

Please use the following standard parts supplied by Gree.

Parts for Outdoor Unit				
Number	Name	Picture	Quantity	Remarks
1	Owner's Manual		1	
2	Wiring (match with resistance)		1	Must be connected to the last IDU of communication connection
3	Mark (Master)		2	Attach on the wired controller of master IDU or on the front panel

3.2 Installation Site

 Forbidden Items! It indicates that improper operation might lead to human casualty or sever injury.

 Items need to be followed. It indicates that improper operation might lead to personal injury or property damage.

		Install the unit at a place where is adequate to withstand the weight of the unit and make sure the unit would not shake or fall off.			Never expose the unit under direct sunshine and rainfall. Install the unit at a place where is against dust, typhoon and earthquake.
		Try to keep the unit away from combustible, inflammable and corrosive gas or exhaust gas.			Leave some space for heat exchanging and servicing so as to guarantee unit normal operation.
		Keep the indoor and outdoor units close to each other as much as possible so as to decrease the pipe length and bends.			Never allow children to approach to the unit and take measures to prevent children touching the unit.

3.2.1 When the outdoor unit is totally surrounded by walls, please refer to following figures for space dimension.

3.2.1.1 Space dimension for single-module unit

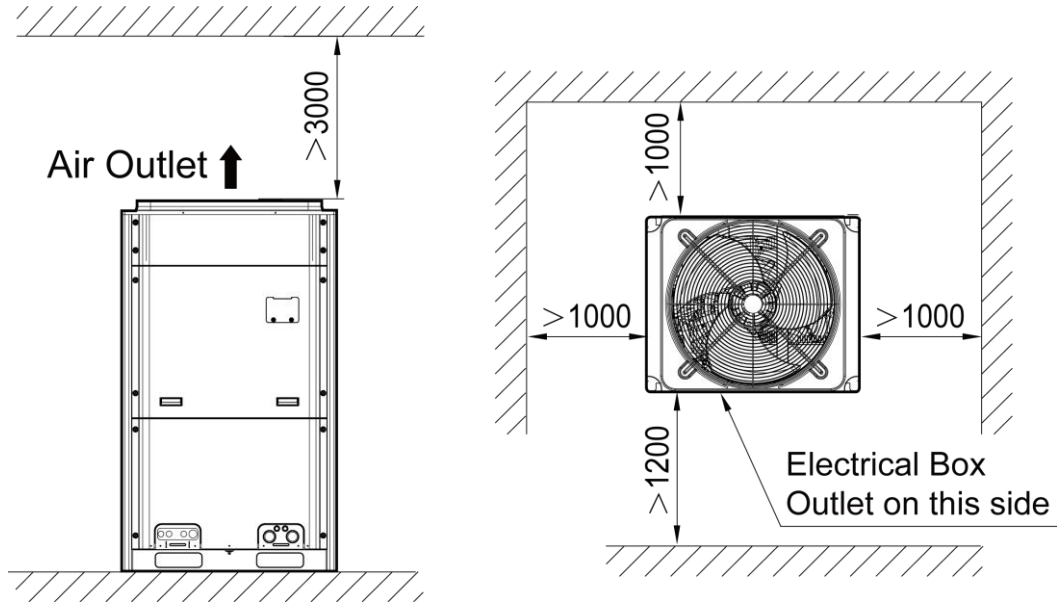

Fig. 3

3.2.1.2 Space dimension for dual-module unit

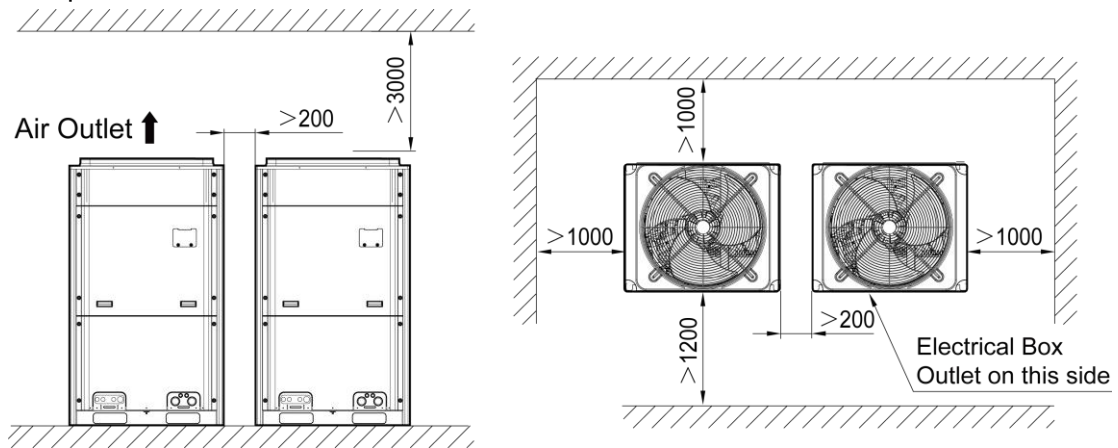

Fig. 4

3.2.1.3 Space dimension for three-module unit

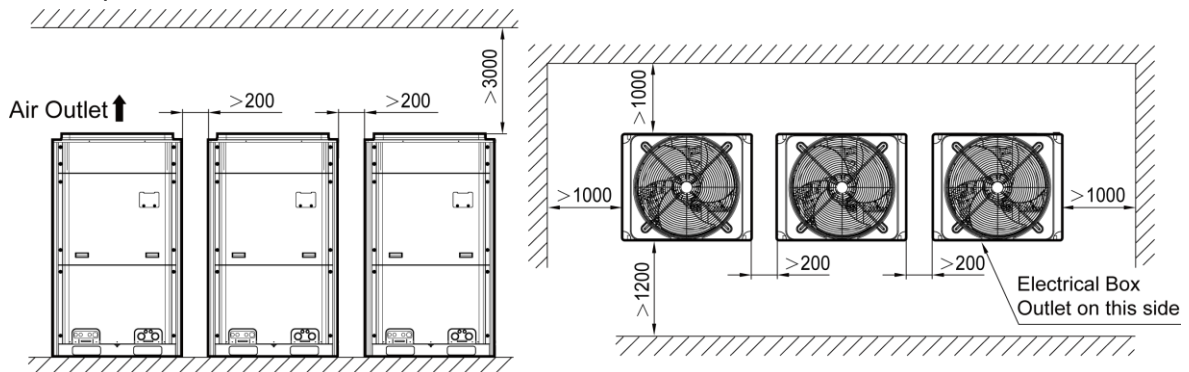

Fig.5

3.2.1.4 Space dimension for four-module unit

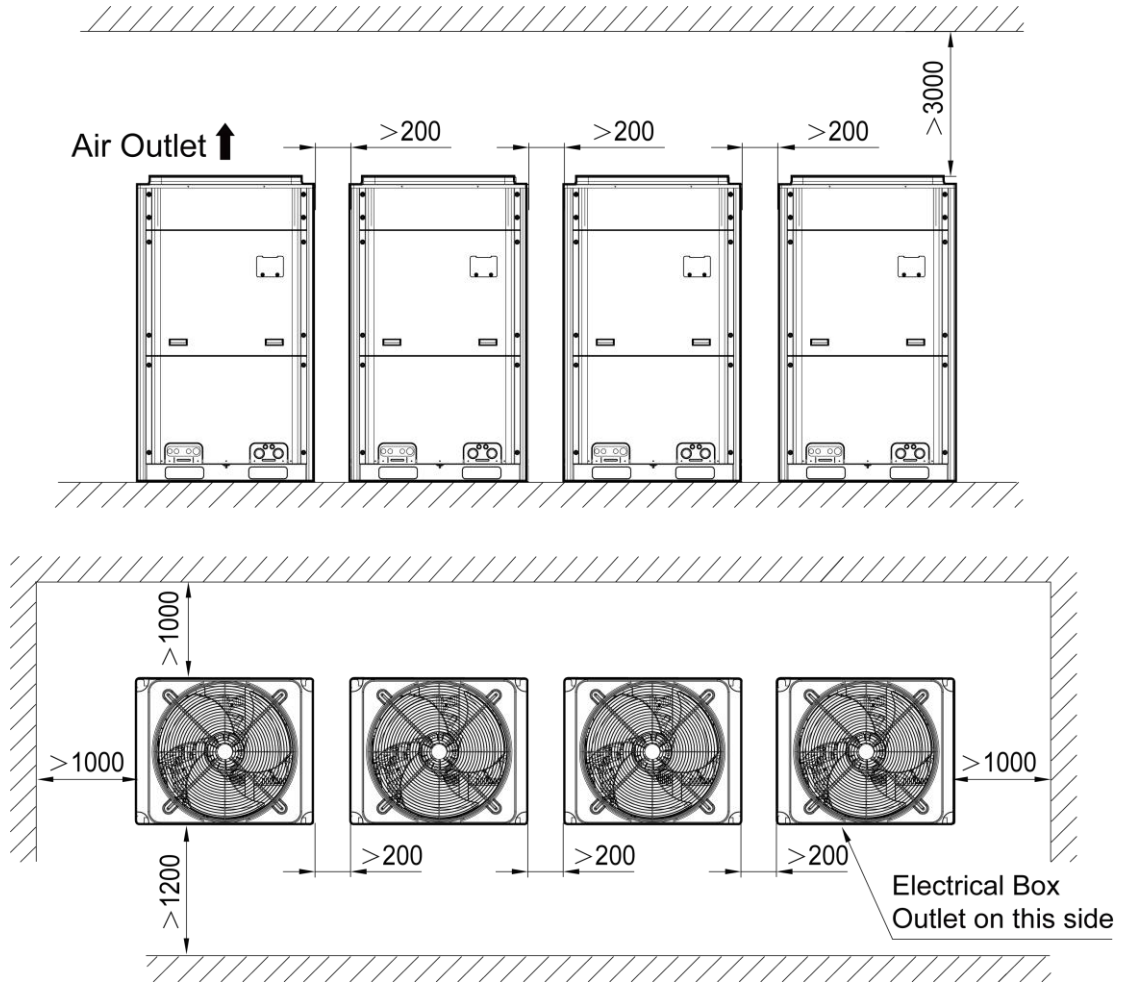

Fig.6

3.2.2 When there is wall (or similar obstruction) above the unit, keep the distance between the unit top and the wall at least 300mm or above. When the unit is located in a totally open space with no obstructions in four directions, keep the distance between the unit top and wall at least 1500mm or above (See Fig.7). When space is limited within 1500mm or the unit is not set in an open space, air return pipe is required to be installed in order to keep good ventilation (See Fig.8).

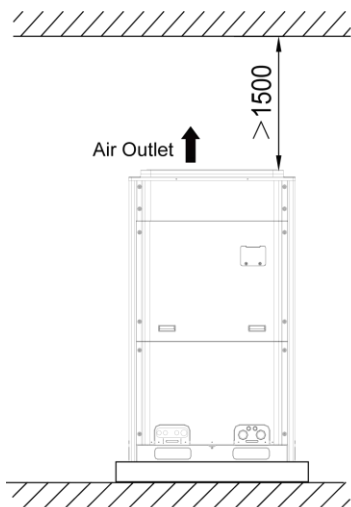

Fig.7

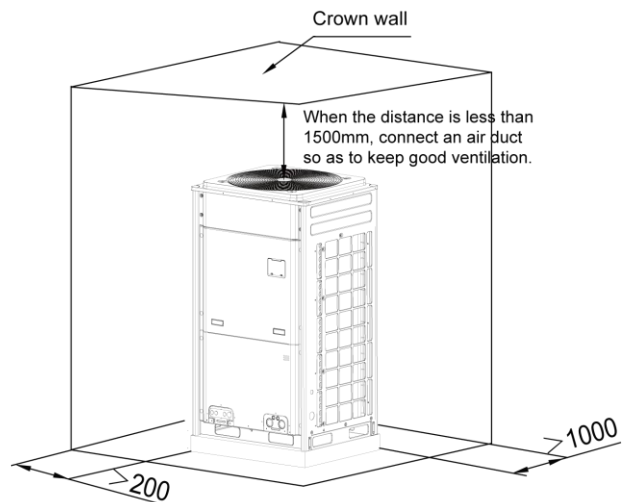

Fig.8

3.2.3 Space dimension for multiple-module unit

For keeping good ventilation, make sure there is no obstructions above the unit.

When the unit is located at a half-open space (front and left/right side is open), install the unit as per the same or opposite direction.

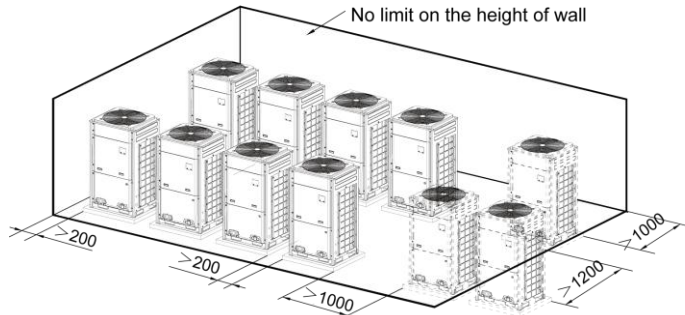

Fig.9

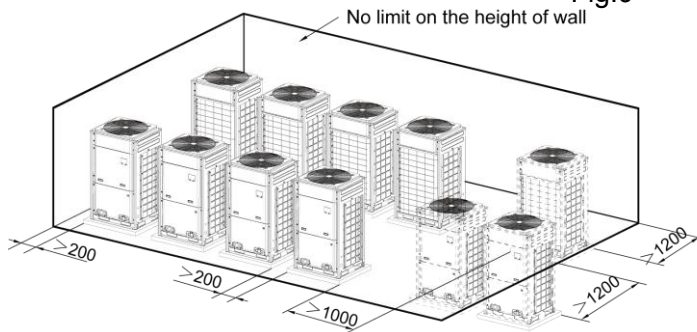
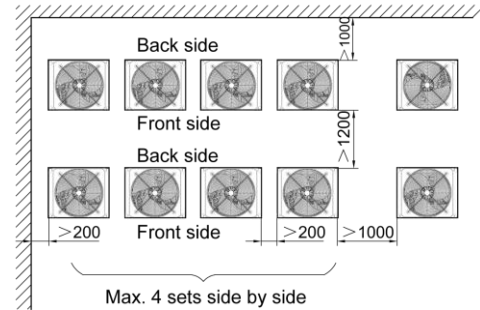
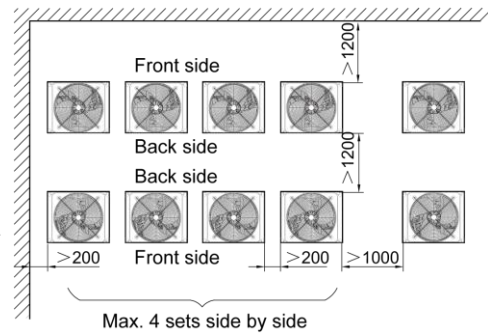

Fig.10



3.2.4 Take seasonal wind into consideration when installing the outdoor unit

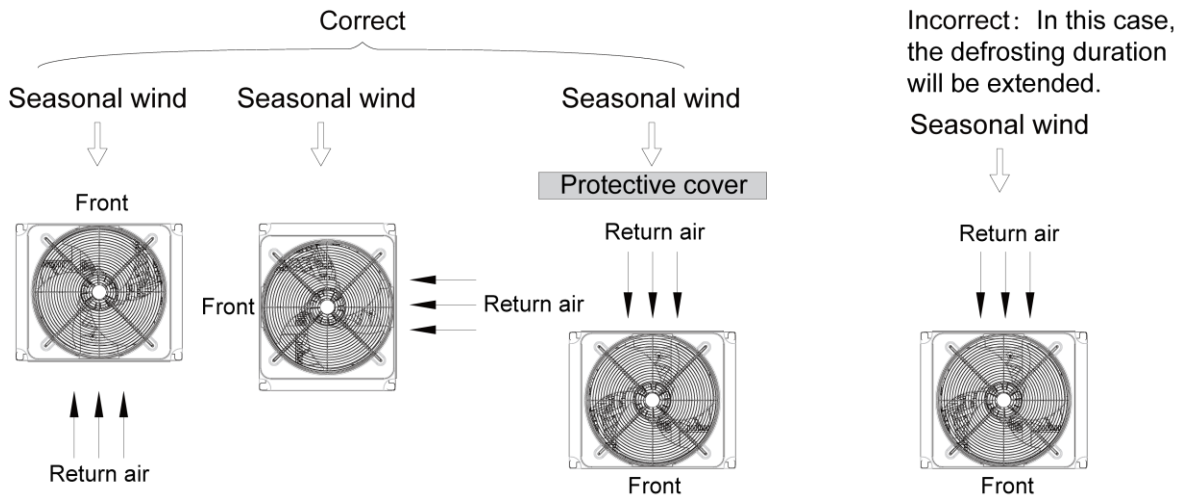

Fig.11

3.2.5 Take snow into consideration when installing the outdoor unit

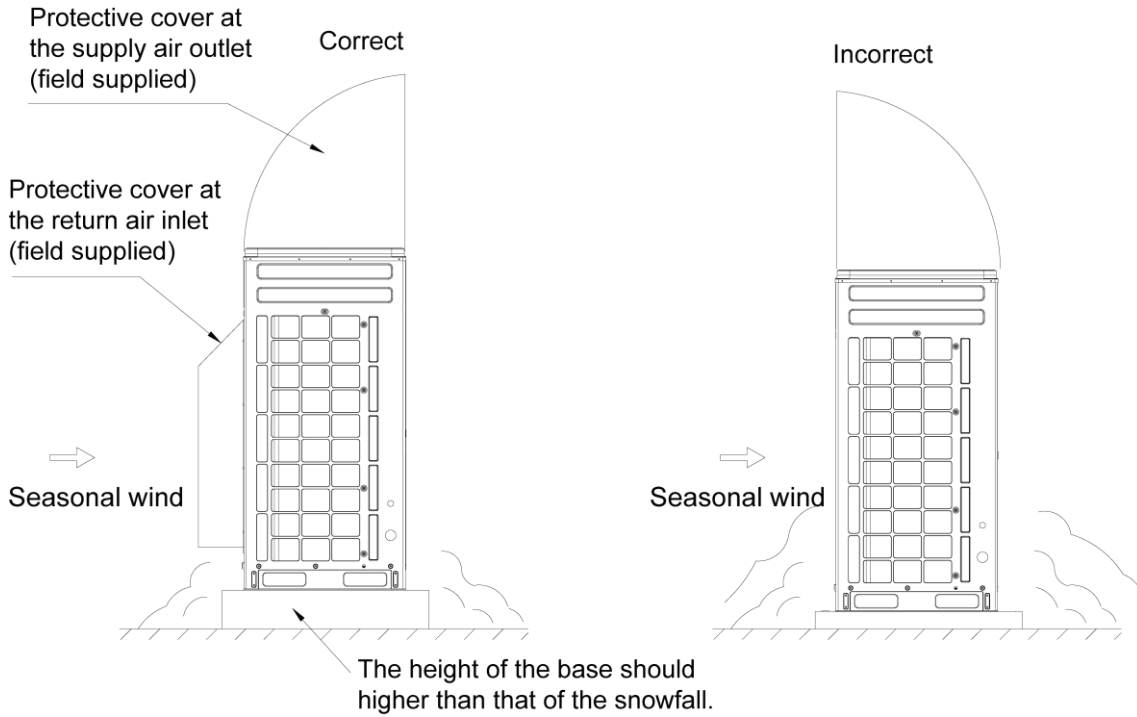

Fig.12

3.3 Piping Work Requirements

There should be no fall among outdoor modules. Refer to the table below for piping work requirements.

R410A Refrigerant System		
Outer Diameter (mm/inch)	Wall Thickness (mm)	Type
Φ6.35(1/4)	≥0.8	0
Φ9.52(3/8)	≥0.8	0
Φ12.70(1/2)	≥0.8	0
Φ15.9(5/8)	≥1.0	0
Φ19.05(3/4)	≥1.0	1/2H
Φ22.2(7/8)	≥1.5	1/2H
Φ25.40(1/1)	≥1.5	1/2H
Φ28.60(9/8)	≥ 1.5	1/2H
Φ34.90(11/8)	≥1.5	1/2H
Φ38.10(12/8)	≥1.5	1/2H
Φ41.30(13/8)	≥1.5	1/2H
Φ44.5(7/4)	≥1.5	1/2H
Φ54.1(17/8)	≥1.5	1/2H

4 Installation Instruction

4.1 Physical Dimension of the Outdoor Unit and Mounting Hole

Outline and Physical Dimension of AMV5-O224 and AMV5-O280 unit

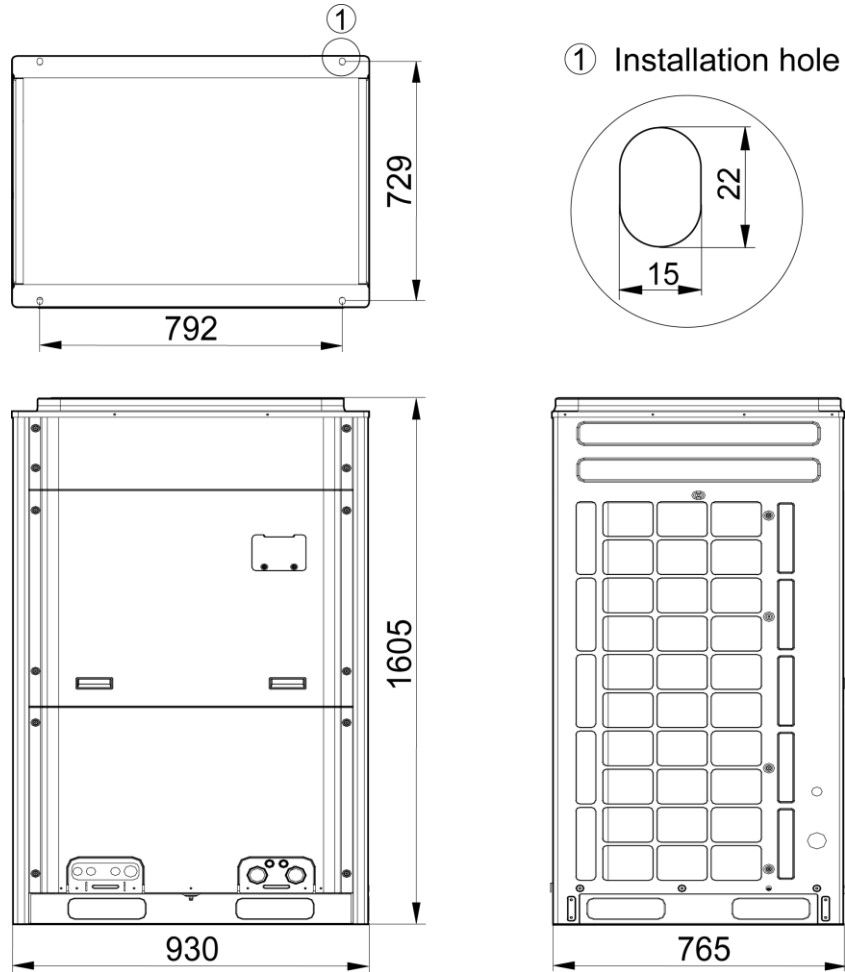

Fig.13

Outline and Physical Dimension of AMV5-O335, AMV5-O400 and AMV5-O450

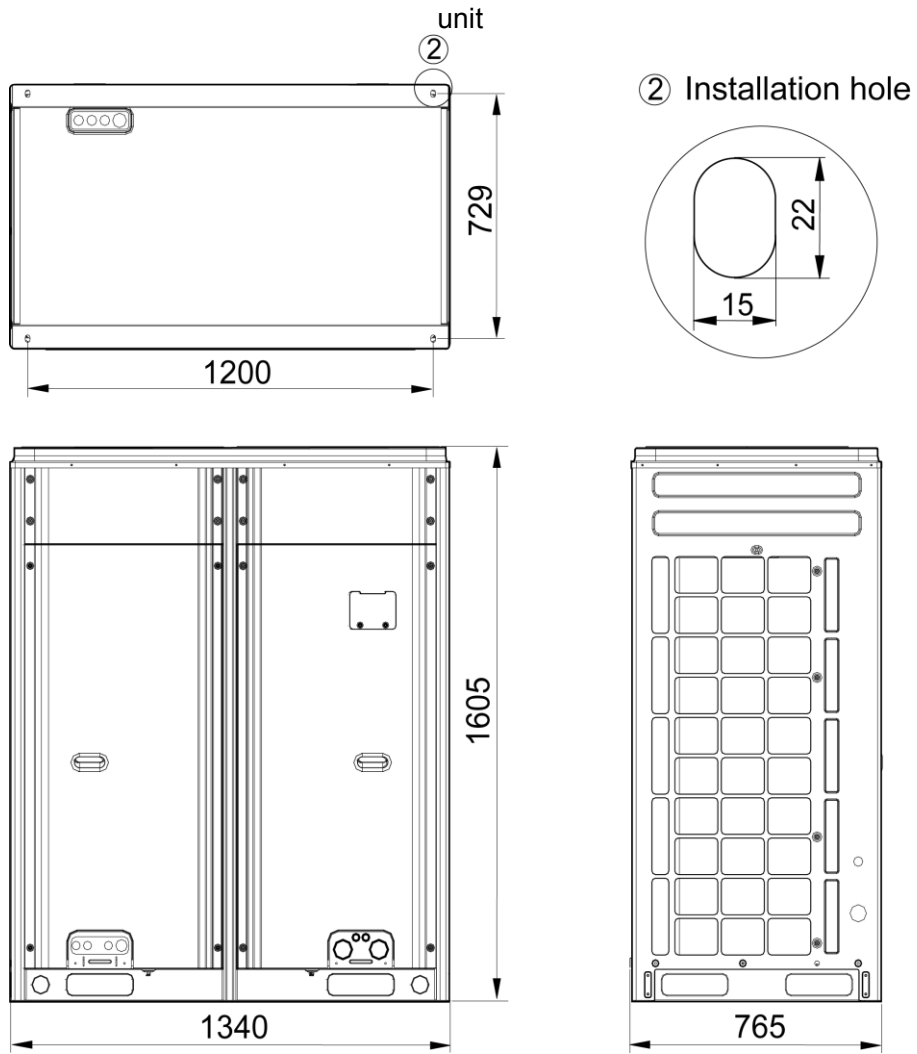

Fig.14

Outline and Physical Dimension of AMV5-O504, AMV5-O560 and AMV5-O615

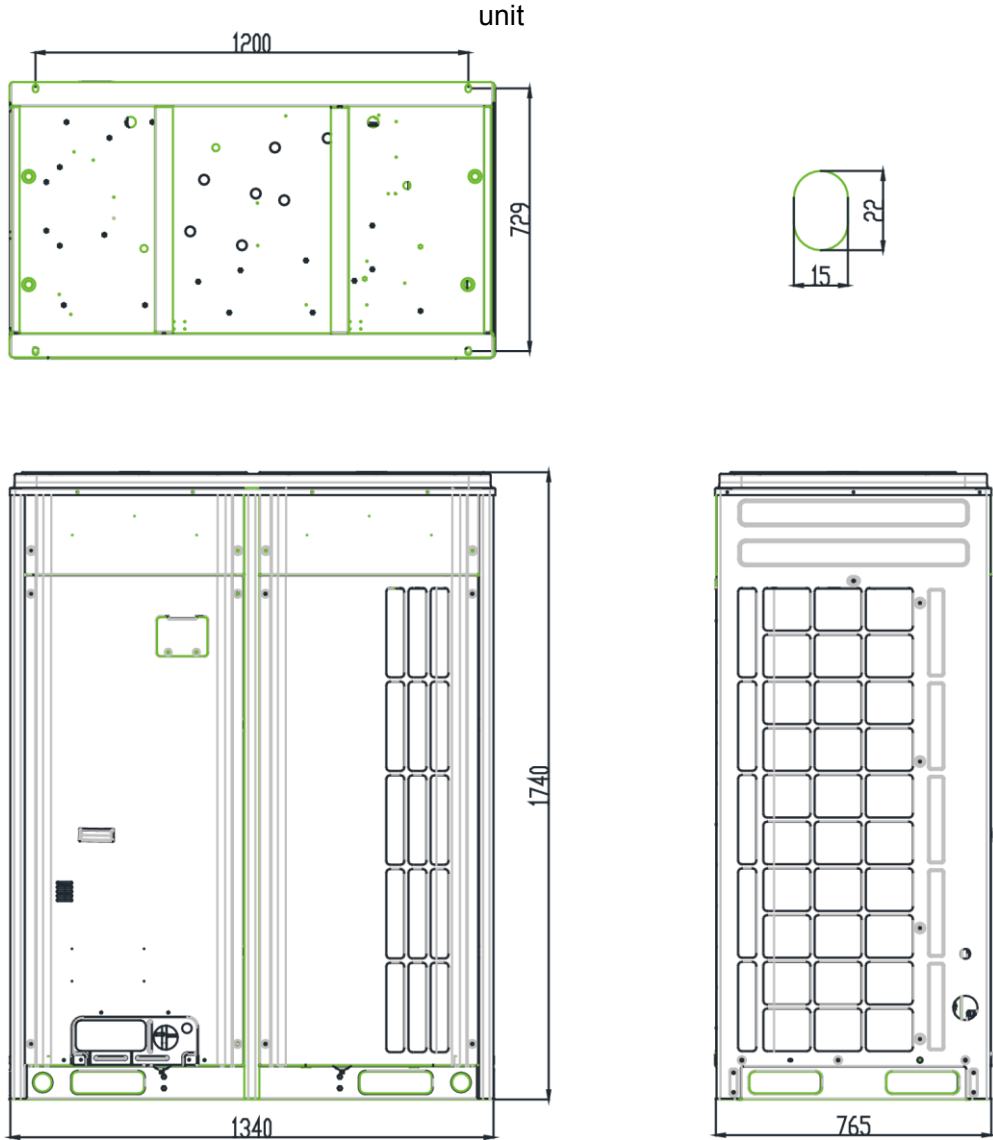

Fig.15

4.2 Connection Pipe

4.2.1 Schematic Diagram of Piping Connection

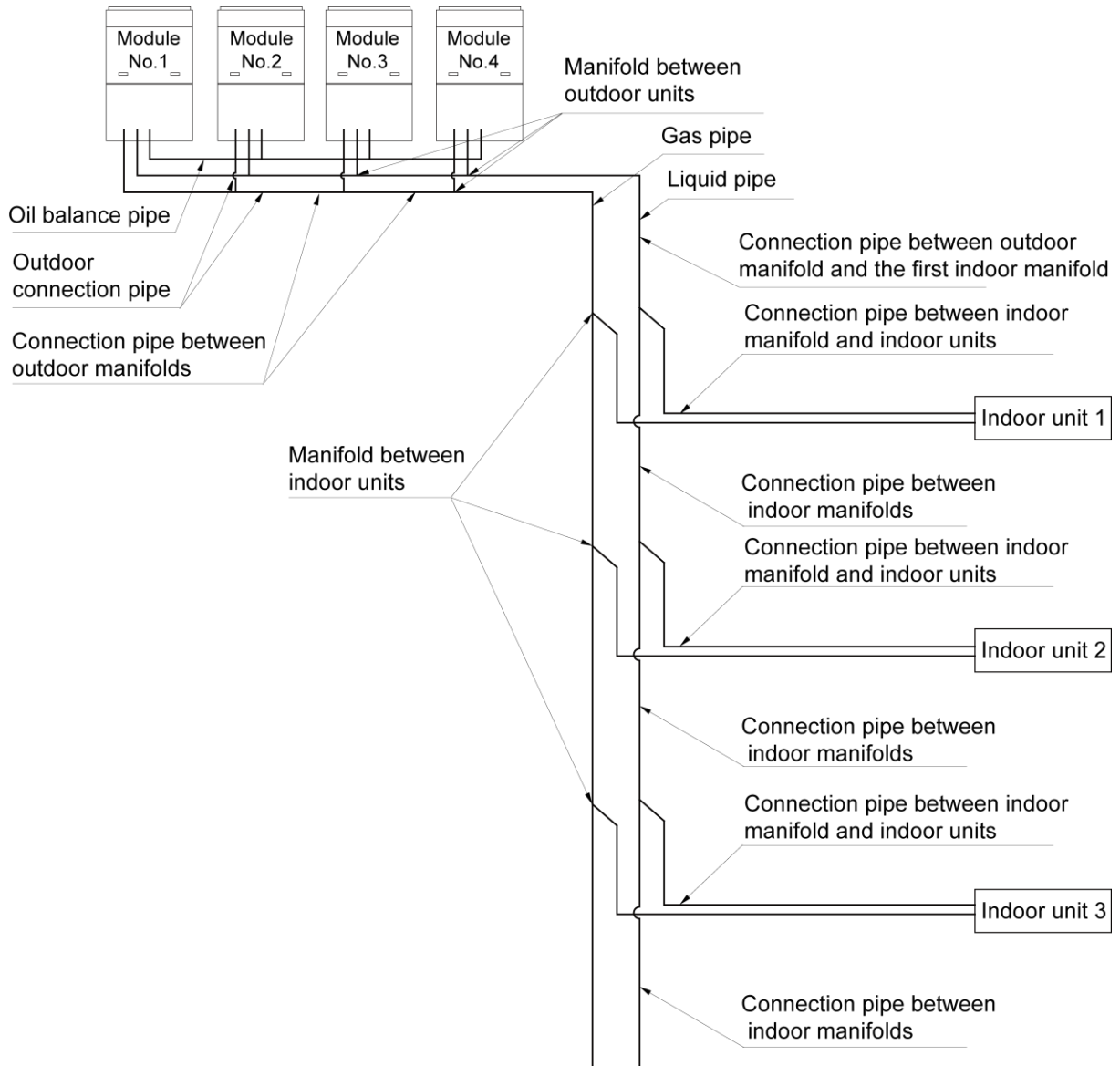

Fig.16

4.2.2 Schematic Diagram of Piping Sequence

AMV5-O224 and AMV5-O280

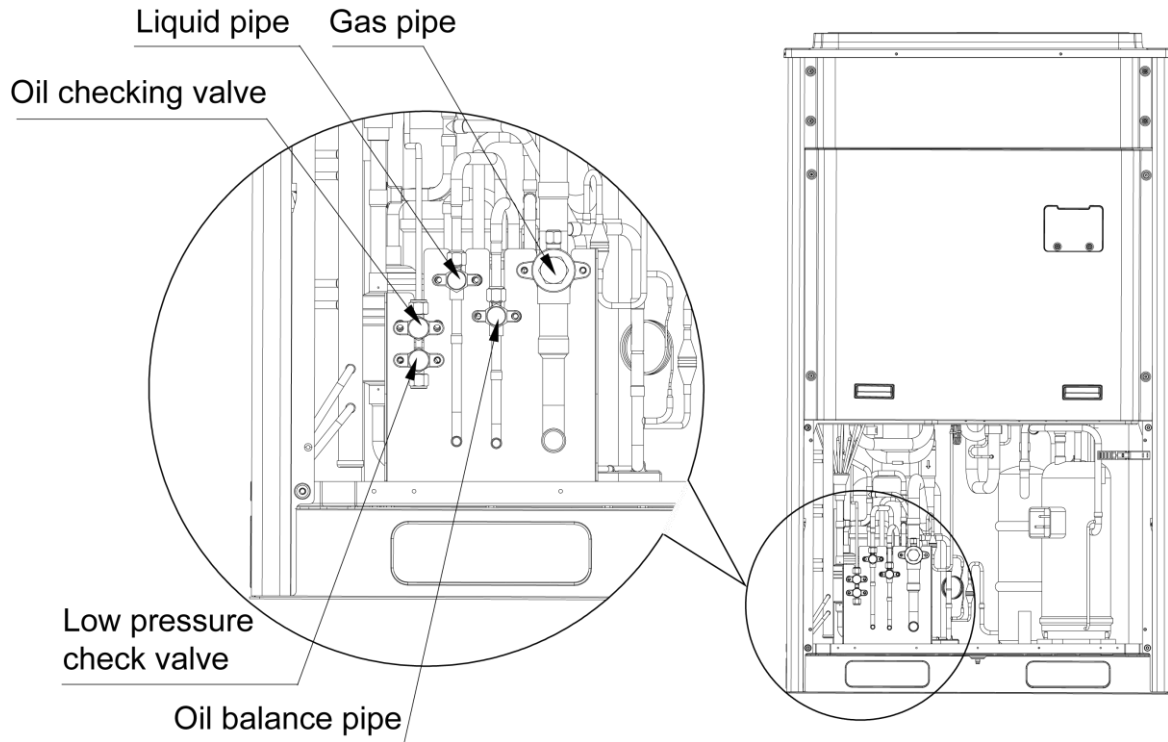

Fig.17

AMV5-O335, AMV5-O400 and AMV5-O450

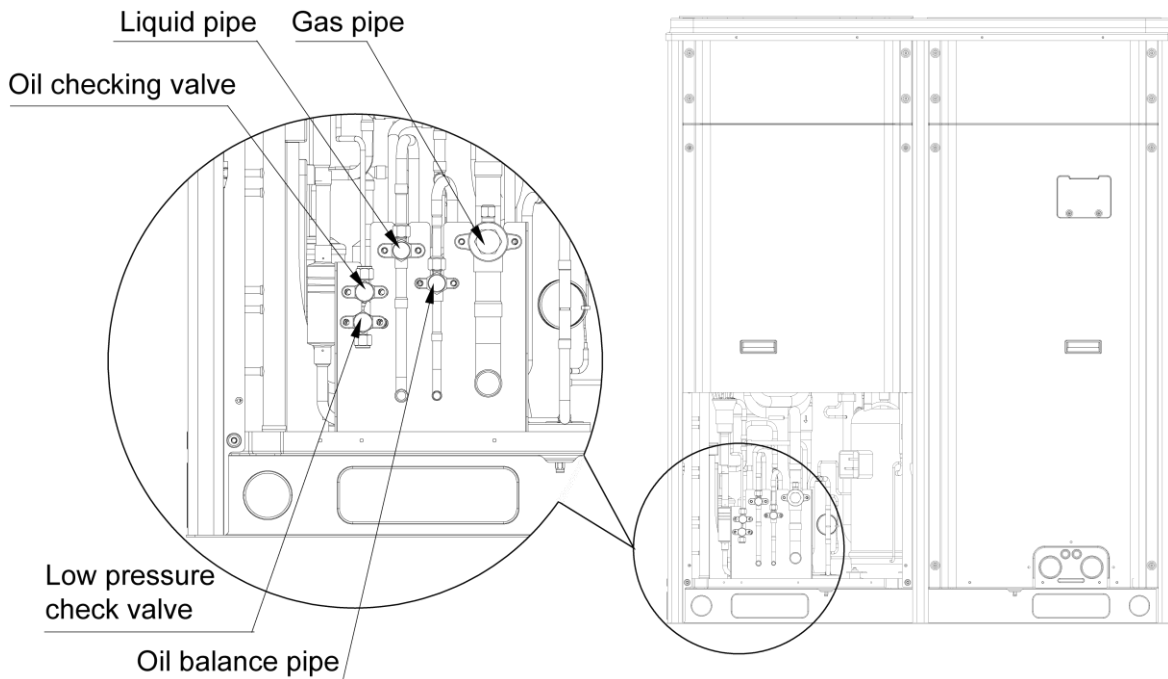
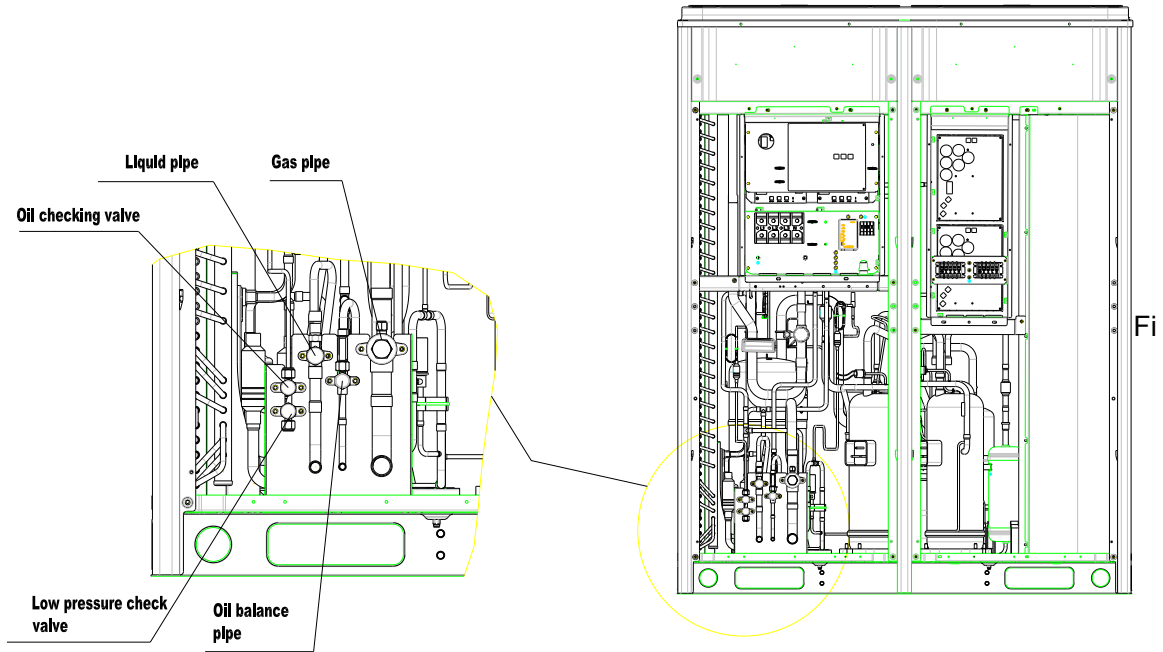

Fig.18

AMV5-O504, AMV5-O560 and AMV5-O615



g.19

4.2.3 Allowable pipe length and drop height among indoor and outdoor units

Y type branch joint is adopted to connect indoor and outdoor units. Connecting method is shown in the figure below.

Remark: Equivalent length of one Y-type manifold is about 0.5m.

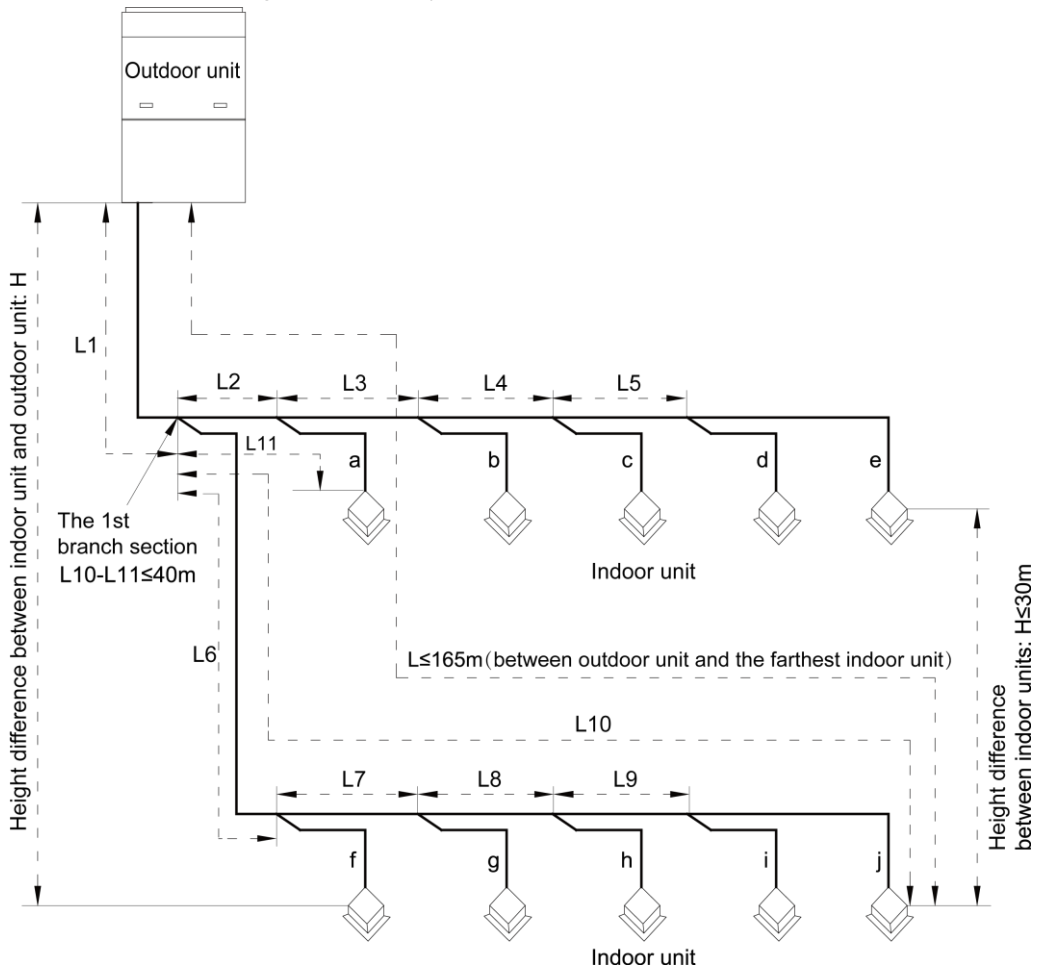

Fig.20

L10: Length from the first branch to the farthest IDU;

L11: Length from the first branch to the nearest IDU;

Equivalent length of branch of IDU is 0.5m

R410A Refrigerant System		Allowable Value	Fitting Pipe
Total length (actual length) of fitting pipe		≤1000	$L1+L2+L3+L4+...+L9+a+b+...+i+j$
Length of farthest fitting pipe(m)	Actual length	≤165	$L1+L6+L7+L8+L9+j$
	Equivalent length	≤190	
Difference between the pipe length from the first branch of IDU to the farthest IDU and the pipe length from the first branch of IDU to the nearest IDU		≤40	L10-L11
Equivalent length from the first branch to the furthest piping (1)		≤40	$L6+L7+L8+L9+j$
Height difference between outdoor unit and indoor unit	Outdoor unit at upper	≤50	—
	Outdoor unit at lower	≤90	—
Height difference between indoor units (m)		≤30	—
Maximum length of Main pipe(2)		≤90	L1
From IDU to its nearest branch (3)		≤10	a,b,c,d,e,f,g,h,i,j

Notices:

(1) Normally, the pipe length from the first branch of IDU to the farthest IDU is 40m. When those three conditions as below are satisfied, the length can reached 90cm.

1) Actual length of pipe in total: $L1+L2x2+L3x2+L4x2+...+L9x2+a+b+...+i+j \leq 1000m$;

2) Length between each IDU and its nearest branch a, b, c, d, e, f, g, h, i, j ≤40m;

3) Difference between the pipe length from the first branch of IDU to the farthest IDU and the pipe length from the first branch of IDU to the nearest IDU: $L10-L11 \leq 40m$.

(2) When the maximum length of the main pipe from ODU to the first branch of IDU is ≥90m, then adjust the pipe size of the gas pipe and liquid pipe of main pipe according to the following table.

Outdoor Model	Gas pipe size(mm)	Liquid pipe size(mm)
AMV5-O224	No need to enlarge pipe size	No need to enlarge pipe size
AMV5-O280	No need to enlarge pipe size	Φ12.7
AMV5-O335	Φ28.6	Φ15.9
AMV5-O400	Φ31.8	Φ15.9
AMV5-O450	Φ31.8	Φ15.9
AMV5-O504	Φ34.9	Φ19.05
AMV5-O560	Φ34.9	Φ19.05
AMV5-O615	Φ34.9	Φ19.05
AMV5-O680	No need to enlarge pipe size	Φ19.05
AMV5-O730	Φ38.1	Φ22.2
AMV5-O785	Φ38.1	Φ22.2

AMV5-O850	Φ38.1	Φ22.2
AMV5-O900	Φ38.1	Φ22.2
AMV5-O960	Φ41.3	Φ22.2
AMV5-O1010	Φ44.5	Φ22.2
AMV5-O1065	Φ44.5	Φ22.2
AMV5-O1130	Φ44.5	Φ22.2
AMV5-O1180	Φ44.5	Φ22.2
AMV5-O1235	Φ44.5	Φ22.2
AMV5-O1300	Φ44.5	Φ22.2
AMV5-O1350	Φ44.5	Φ22.2
AMV5-O1410	Φ44.5	Φ25.4
AMV5-O1460	Φ44.5	Φ25.4
AMV5-O1515	Φ44.5	Φ25.4
AMV5-O1580	Φ44.5	Φ25.4
AMV5-O1630	Φ44.5	Φ25.4
AMV5-O1685	Φ44.5	Φ25.4
AMV5-O1750	Φ44.5	Φ25.4
AMV5-O1800	Φ44.5	Φ25.4
AMV5-O1845	Φ44.5	Φ25.4
AMV5-O1908	Φ51.4	Φ25.4
AMV5-O1962	Φ51.4	Φ25.4
AMV5-O2016	Φ51.4	Φ25.4
AMV5-O2072	Φ51.4	Φ25.4
AMV5-O2128	Φ51.4	Φ25.4
AMV5-O2184	Φ51.4	Φ25.4
AMV5-O2240	Φ51.4	Φ25.4
AMV5-O2295	Φ51.4	Φ25.4
AMV5-O2350	Φ51.4	Φ25.4
AMV5-O2405	Φ51.4	Φ25.4
AMV5-O2460	Φ51.4	Φ25.4

(3) If the length between an IDU and its nearest branch is above 10m, then increase the size of the liquid pipe of IDU (only for the pipe size that is ≤6.35mm).

4.2.4 Connection Pipe among Outdoor Modules

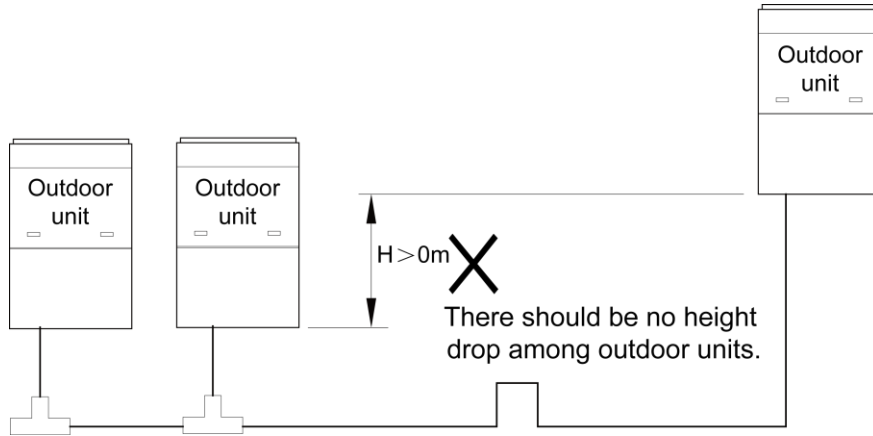

Fig.21

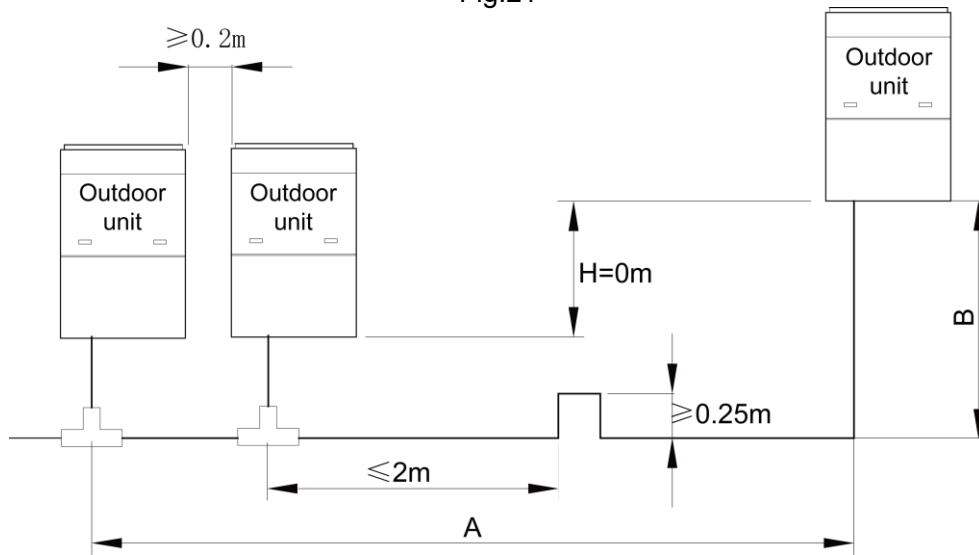

Fig.22

Note: When the distance between outdoor units exceeds 2m, U-type oil trap should be added at low-pressure gas pipe. $A+B \leq 10m$.

4.2.5 Fitting pipe between Outdoor Unit and the First Manifold

4.2.5.1 For single module system, pipe size (between outdoor unit and the first manifold) is determined by that of outdoor unit.

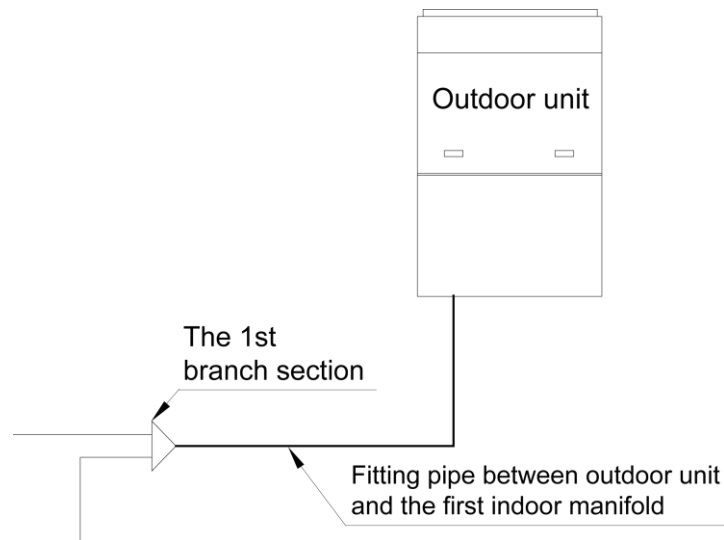

Fig.23

Pipe size of basic outdoor module is shown as follows:

Basic Module	Pipe between ODU and the first branch of IDU	
	Gas Pipe(mm)	Liquid Pipe(mm)
AMV5-O224	Φ19.05	Φ9.52
AMV5-O280	Φ22.2	Φ9.52
AMV5-O335	Φ25.4	Φ12.7
AMV5-O400	Φ25.4	Φ12.7
AMV5-O450	Φ28.6	Φ12.7
AMV5-O504	Φ28.6	Φ15.9
AMV5-O560	Φ28.6	Φ15.9
AMV5-O615	Φ28.6	Φ15.9

4.2.5.2 For multi-module unit, select appropriate manifold connected to outdoor module as per the pipe size of basic module. Pipe size of basic outdoor module is shown as follows:

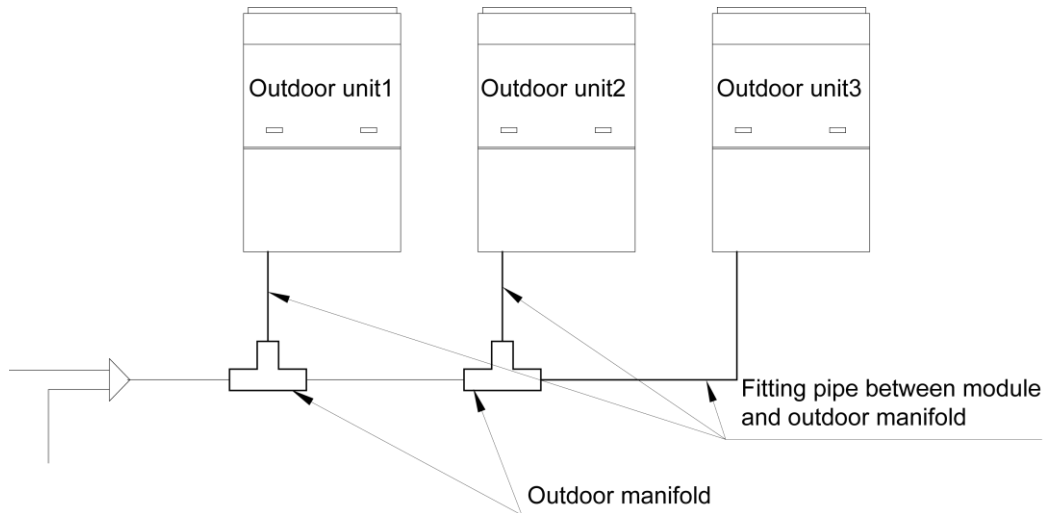

Fig.24

Basic Module	Pipe between module and branch of ODU	
	Gas Pipe(mm)	Liquid Pipe(mm)
AMV5-O224	Φ19.05	Φ9.52
AMV5-O280	Φ22.2	Φ9.52
AMV5-O335	Φ25.4	Φ12.7
AMV5-O400	Φ25.4	Φ12.7
AMV5-O450	Φ28.6	Φ12.7
AMV5-O504	Φ28.6	Φ15.9
AMV5-O560	Φ28.6	Φ15.9
AMV5-O615	Φ28.6	Φ15.9

Select the branch of outdoor module

	Module's capacity (C)	Model
Select the branch of outdoor module	$504 \leq C$	ML01/A

4.2.5.3 Fitting pipe between two manifolds from basic modules

Pipe size (between two manifolds from basic modules) is based on the total capacity of upstream modules.

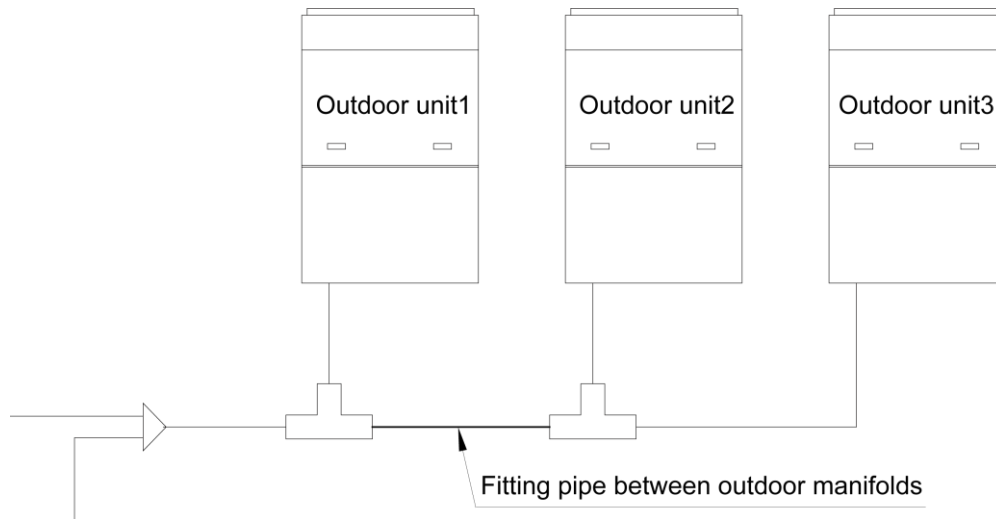

Fig.25

Total capacity of upstream modules Q(kW)	Pipe size between manifolds	
	Gas Pipe(mm)	Liquid Pipe(mm)
$22.4 \geq Q$	$\Phi 19.05$	$\Phi 9.52$
$28.0 \geq Q > 22.4$	$\Phi 22.2$	$\Phi 9.52$
$40.0 \geq Q > 28.0$	$\Phi 25.4$	$\Phi 12.7$
$45.0 \geq Q > 40.0$	$\Phi 28.6$	$\Phi 12.7$
$68.0 \geq Q > 45.0$	$\Phi 28.6$	$\Phi 15.9$
$96.0 \geq Q > 68.0$	$\Phi 31.8$	$\Phi 19.05$
$135.0 \geq Q > 96.0$	$\Phi 38.1$	$\Phi 19.05$
$Q \geq 135.0$	$\Phi 44.5$	$\Phi 22.2$

4.2.5.4 Fitting pipe between the first manifold from indoor unit and the end manifold from outdoor unit

Single module unit

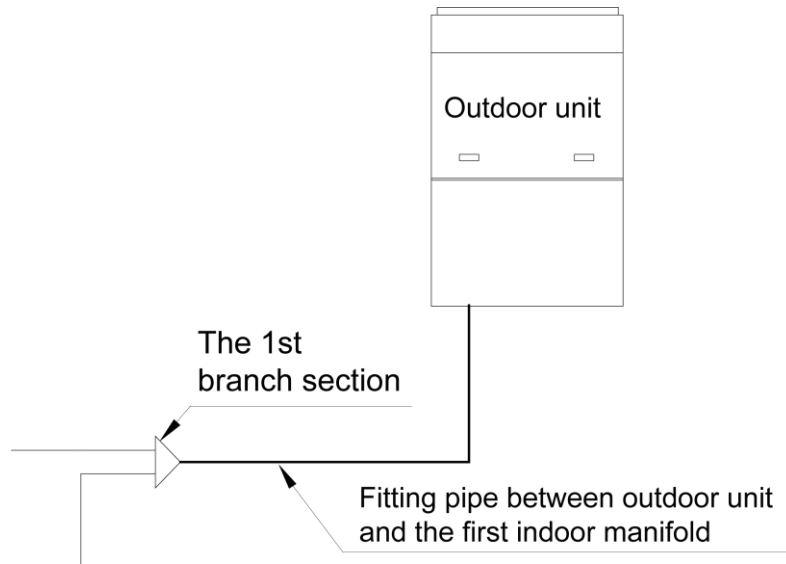

Fig.26

Basic Module(single module)	Pipe between ODU and the first branch of IDU	
	Gas Pipe(mm)	Liquid Pipe(mm)
AMV5-O224	Φ19.05	Φ9.52
AMV5-O280	Φ22.2	Φ9.52
AMV5-O335	Φ25.4	Φ12.7
AMV5-O400	Φ25.4	Φ12.7
AMV5-O450	Φ28.6	Φ12.7
AMV5-O504	Φ28.6	Φ15.9
AMV5-O560	Φ28.6	Φ15.9
AMV5-O615	Φ28.6	Φ15.9

For multiple modules, the piping from ODU to the first branch of IDU is based on the total rated capacity of outdoor modules.

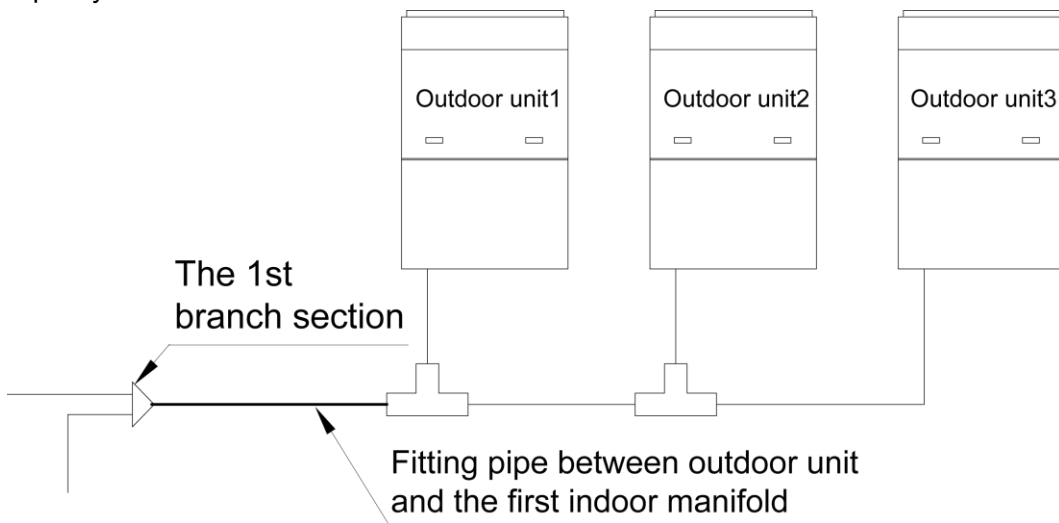

Fig.27

Total rated capacity of outdoor modules (multi-modular system)	Pipe between ODU and the first branch of IDU	
	Gas Pipe(mm)	Liquid Pipe(mm)
AMV5-O504	Φ28.6	Φ15.9
AMV5-O560	Φ28.6	Φ15.9
AMV5-O615	Φ28.6	Φ15.9
AMV5-O680	Φ28.6	Φ15.9
AMV5-O730	Φ31.8	Φ19.05
AMV5-O785	Φ31.8	Φ19.05
AMV5-O850	Φ31.8	Φ19.05
AMV5-O900	Φ31.8	Φ19.05
AMV5-O960	Φ31.8	Φ19.05
AMV5-O1010	Φ38.1	Φ19.05
AMV5-O1065	Φ38.1	Φ19.05
AMV5-O1130	Φ38.1	Φ19.05
AMV5-O1180	Φ38.1	Φ19.05
AMV5-O1235	Φ38.1	Φ19.05
AMV5-O1300	Φ38.1	Φ19.05
AMV5-O1350	Φ38.1	Φ19.05
AMV5-O1410	Φ44.5	Φ22.2
AMV5-O1460	Φ44.5	Φ22.2
AMV5-O1515	Φ44.5	Φ22.2
AMV5-O1580	Φ44.5	Φ22.2
AMV5-O1630	Φ44.5	Φ22.2
AMV5-O1685	Φ44.5	Φ22.2
AMV5-O1750	Φ44.5	Φ22.2
AMV5-O1800	Φ44.5	Φ22.2
AMV5-O1845	Φ41.3	Φ19.05
AMV5-O1908	Φ44.5	Φ22.2
AMV5-O1962	Φ44.5	Φ22.2
AMV5-O2016	Φ44.5	Φ22.2
AMV5-O2072	Φ44.5	Φ22.2
AMV5-O2128	Φ44.5	Φ22.2
AMV5-O2184	Φ44.5	Φ22.2
AMV5-O2240	Φ44.5	Φ22.2
AMV5-O2295	Φ44.5	Φ22.2
AMV5-O2350	Φ44.5	Φ22.2
AMV5-O2405	Φ44.5	Φ22.2
AMV5-O2460	Φ44.5	Φ22.2

4.2.5.5 Manifold at indoor unit side

Manifold at indoor unit side can be selected as per total capacity of downstream indoor unit(s). Refer to the following table.

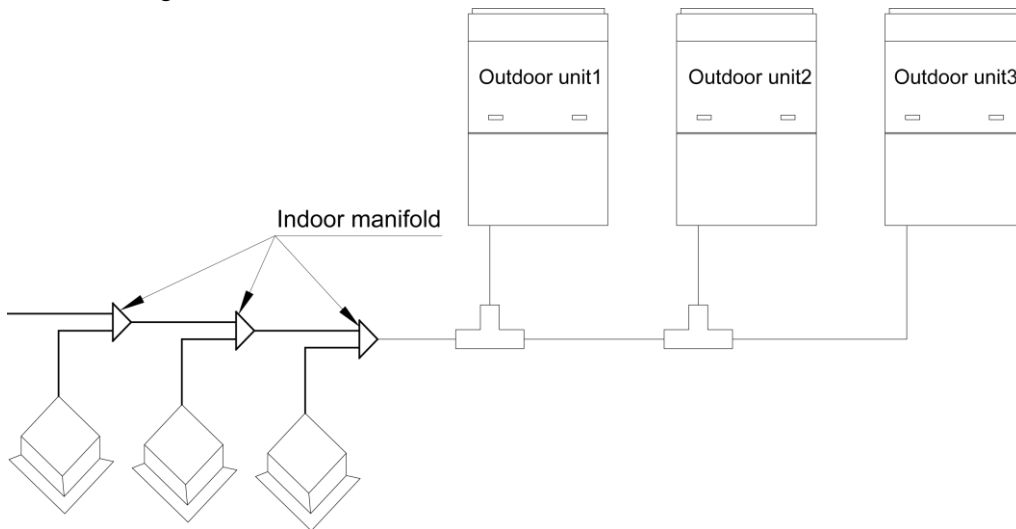

Fig.28

R410A Refrigerant System	Total capacity of downstream indoor unit(s) C (kW)	Model
Y-type Manifold	$C \leq 20.0$	FQ01A/A
	$20.0 < C \leq 30.0$	FQ01B/A
	$30.0 < C \leq 70.0$	FQ02/A
	$70.0 < C \leq 135.0$	FQ03/A
	$135.0 < C$	FQ04/A

4.2.5.6 Fitting pipe between manifolds

Pipe size (between two manifolds at indoor unit side) is based on the total capacity of upstream indoor unit(s).

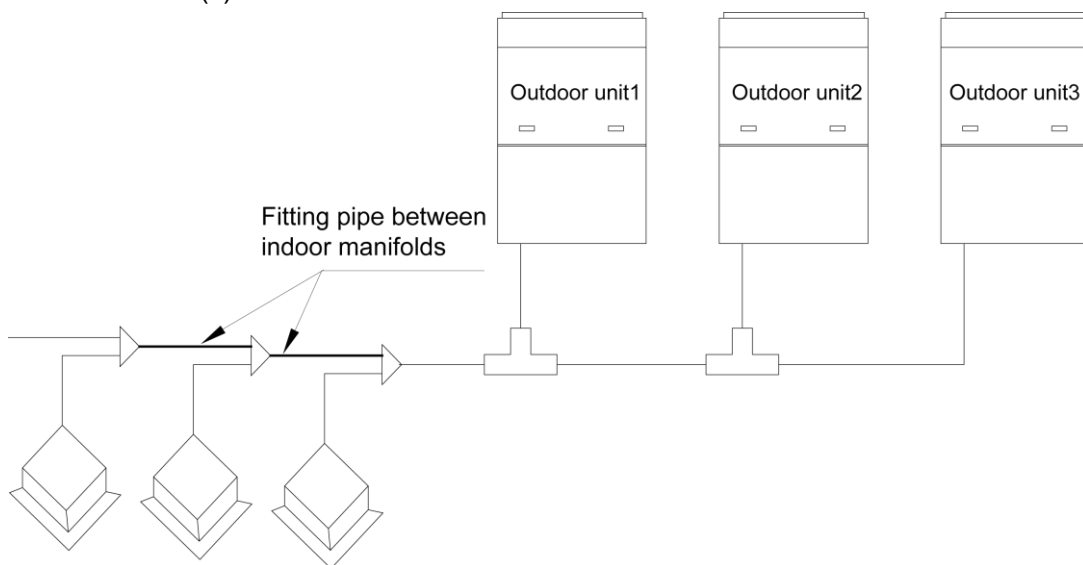

Fig.29

Total capacity of downstream indoor unit(s) C(kW)	Dimension of the pipe of indoor branch	
	Gas Pipe(mm)	Liquid Pipe (mm)

$C \leq 5.6$	$\Phi 12.7$	$\Phi 6.35$
$5.6 < C \leq 14.2$	$\Phi 15.9$	$\Phi 9.52$
$14.2 < C \leq 22.4$	$\Phi 19.05$	$\Phi 9.52$
$22.4 < C \leq 28.0$	$\Phi 22.2$	$\Phi 9.52$
$28.0 < C \leq 40.0$	$\Phi 25.4$	$\Phi 12.7$
$40.0 < C \leq 45.0$	$\Phi 28.6$	$\Phi 12.7$
$45.0 < C \leq 68.0$	$\Phi 28.6$	$\Phi 15.9$
$68.0 < C \leq 96.0$	$\Phi 31.8$	$\Phi 19.05$
$96.0 < C \leq 135.0$	$\Phi 38.1$	$\Phi 19.05$
$135.0 < C$	$\Phi 44.5$	$\Phi 22.2$

4.2.5.7 Fitting pipe between indoor unit and manifold

Manifold should be matched with fitting pipe of indoor unit.

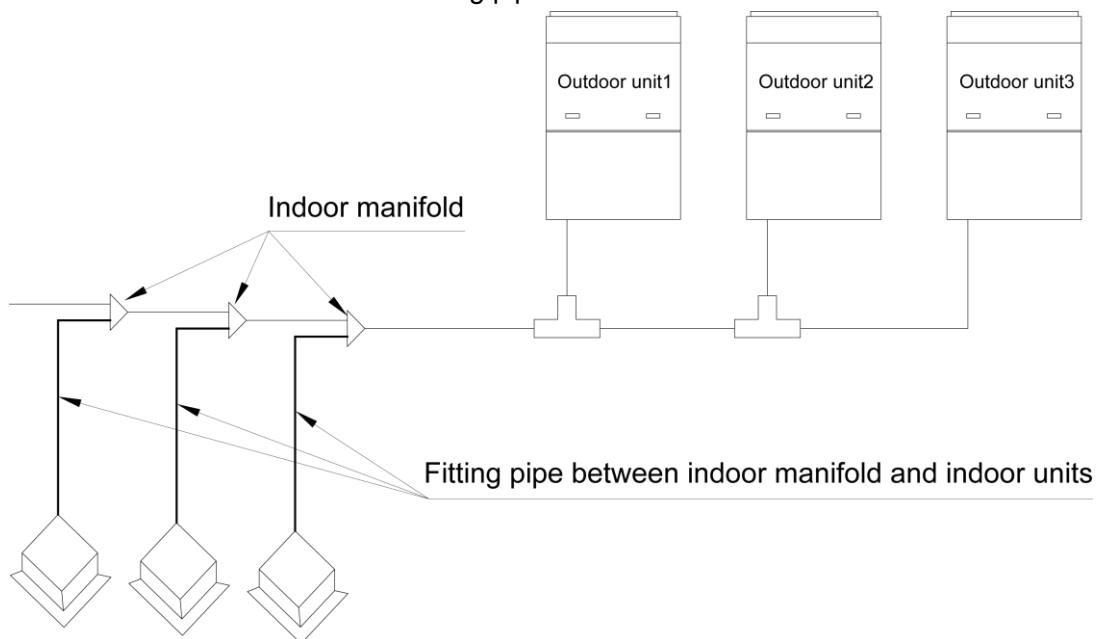

Fig.30

Rated capacity of indoor unit C(kW)	Pipe between indoor branch and IDU	
	Gas Pipe(mm)	Liquid Pipe(mm)
$C \leq 2.8$	$\Phi 9.52$	$\Phi 6.35$
$2.8 < C \leq 5.0$	$\Phi 12.7$	$\Phi 6.35$
$5.0 < C \leq 14.0$	$\Phi 15.9$	$\Phi 9.52$
$14.0 < C \leq 16.0$	$\Phi 19.05$	$\Phi 9.52$
$16.0 < C \leq 28.0$	$\Phi 22.2$	$\Phi 9.52$

4.3 Installation of the Connection Pipe

4.3.1 Precautions when installing the connection pipe

- (1) Conform to the following principles during piping connection: Connection pipeline should be as short as possible. The height difference between indoor and outdoor units should be as short as possible. Keep number of bends as little as possible. The radius of curvature should be as large as possible.

- (2) Weld the connection pipes between indoor and outdoor unit. Please strictly conform to the requirements for welding process. Rosin joints and pin holes are not allowable.
- (3) When laying the pipes, be careful not to deform them. The radius of bending parts should be more than 200mm. The pipes can not be repeatedly bent or stretched, otherwise the material will get harder. Do not bend or stretch the pipe over three times at the same position.
- (4) Please use a torque wrench to connect union nut on the indoor unit. See Fig. 29.

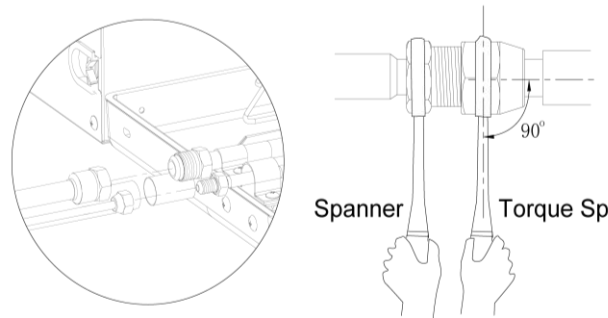

Fig.31

- 1) Align the expansion end of copper pipe with the center of threaded joint. Tighten the flare nuts with your hands.
- 2) Tighten the flare nuts with torque wrench until you hear "click" sound.
- 3) Use sponge to wrap the connecting pipe and joints without thermal insulation and tie it up with plastic tape.
- 4) A mounting support for the connection pipe is required.
- 5) The curvature degree of connection pipe should not be small, otherwise the pipe might crack. Installation personnel should use tube bender when bending the pipe.
- 6) Don't forcibly stretch the pipe joint, otherwise indoor capillary or other pipes might be damaged and lead to refrigerant leakage.

4.3.2 Y-type manifold

- (1) Y-type manifold

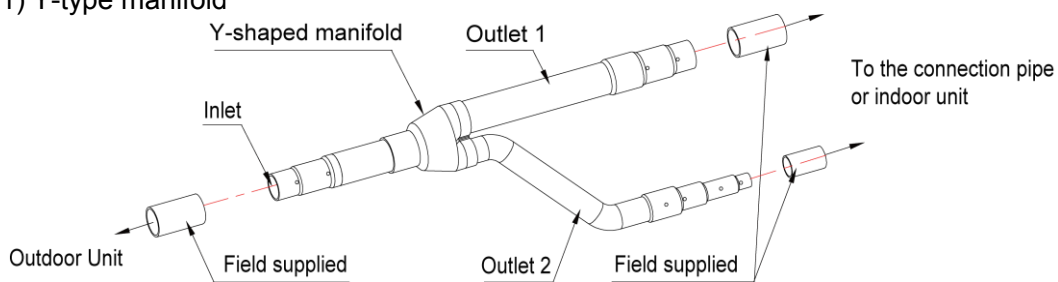

Fig.32

- (2) Y-type manifold has several pipe sections with different pipe size, which facilitates to match with various copper pipe. Use pipe cutter to cut in the middle of the pipe section with different pipe size and deburr as well. See Fig.31.
- (3) Y-type manifold must be installed vertically or horizontally.

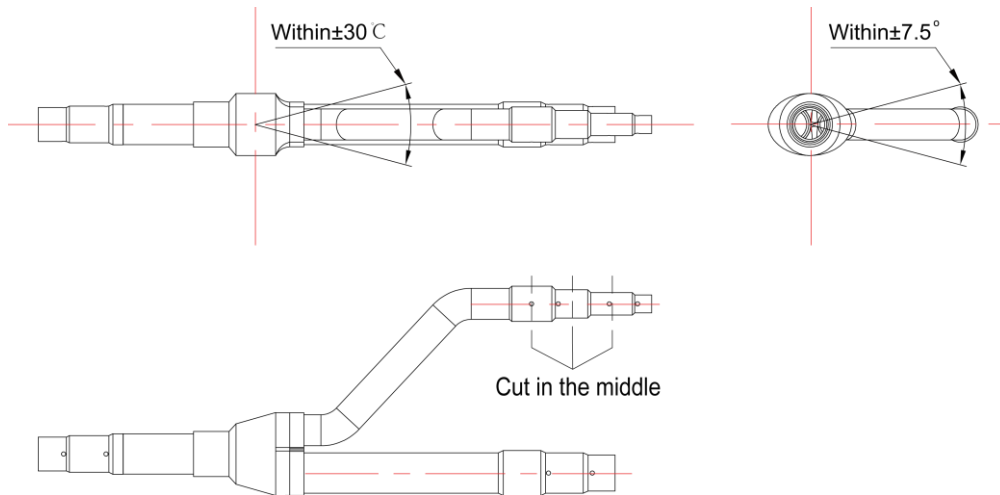
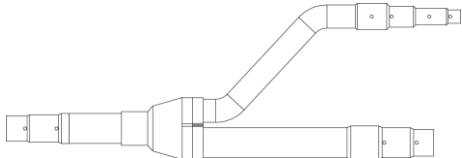

Fig.33

Y-type manifold	Total capacity of downstream indoor unit(s) (X)	Model
	$X \leq 200$	FQ01A/A
	$200 < X \leq 300$	FQ01B/A
	$300 < X \leq 700$	FQ02/A
	$700 < X \leq 1350$	FQ03/A
	$1350 < X$	FQ04/A

(4) Manifold is isolated by insulating material that can bear 120°C or higher temperature.

Manifold attached foam can not be taken as insulating material.

4.3.3 Thermal insulation for pipeline

(1) For multi VRF system, every copper pipe should be labeled so as to avoid misconnection.

(2) At the manifold inlet, at least leave 500mm straight pipe section, and for FQ04 manifold, keep it at least 800mm.

(3) Thermal insulation for pipeline

1) To avoid condensate or water leakage on connecting pipe, the gas pipe and liquid pipe must be wrapped with thermal insulating material and adhesive pipe for insulation from the air.

2) For heat pump unit, liquid pipe should bear 70°C or above, and gas pipe should bear 120°C or above. For cooling only unit, both liquid pipe and gas pipe should bear 70°C or above. Example: Polyethylene foam can bear 120°C above and foaming polyethylene can bear 100°C above.

3) Joints at indoor and outdoor units should be wrapped with insulating material and leave no clearance between pipe and wall. See Fig.32.

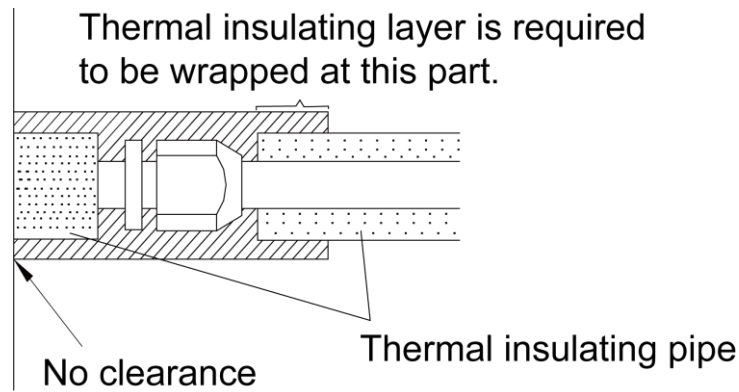

Fig.34

- 4) Manifold attached foam can not be taken as insulating material.
- 5) When wrapping the tape, the later circle should cover half of the former one. Don't wrap the tape so tightly, otherwise the insulation effect will be weakened.
- 6) After wrapping the pipe, adopt sealing material to completely fill the hole so as to prevent wind and rain from entering the room.

4.3.4 Support and protection for pipeline

- (1) Support should be made for hanging connection pipe. Distance between each support can not be over 1m.
- (2) Protection towards accidental damage should be made for outdoor pipeline. When the pipeline exceeds 1m, a pinch board should be added for protection.

4.4 Air Purging and Refrigerant Charge

4.4.1 Air purging

- (1) Confirm outdoor liquid and gas valves are closed. Air purging from the nozzle located on liquid and gas valves by vacuum pump. See Fig.33.
- (2) When there are more than 2 outdoor units, air purging from the nozzle located on the oil balance valve. Confirm outdoor oil balance valves are closed. See Fig.34.

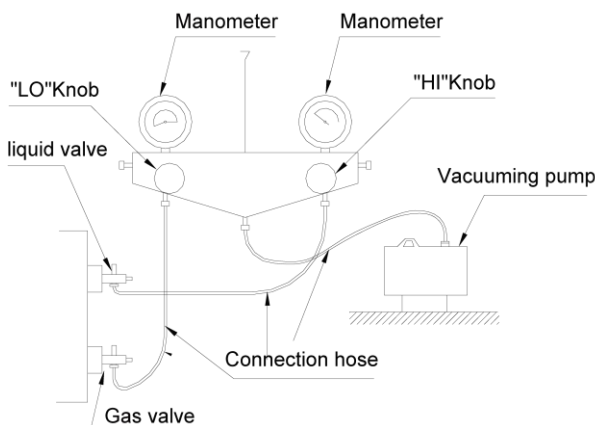

Fig.35

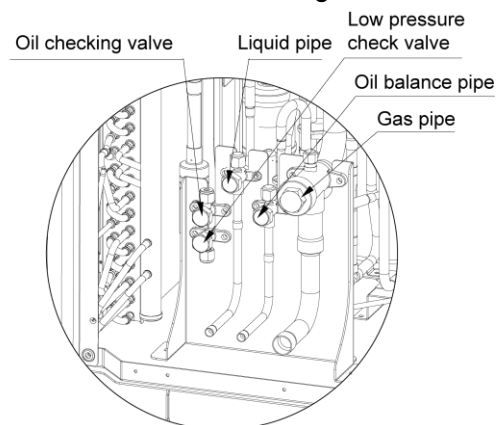

Fig.36

4.4.2 Additional refrigerant charging

Outdoor unit has been charged refrigerant before delivery.

Charge additional refrigerant for field-installed connecting pipe. If the pipeline is longer than 1m, please refer to the following table for charging amount of refrigerant. (Liquid pipe prevails)

How much additional refrigerant should be charged

Total refrigerant charging amount $R = \text{Pipeline charging amount } A + \sum \text{charging amount } B \text{ of every module}$

(1) Pipeline charging amount

Pipeline charging amount $A = \sum \text{Liquid pipe length} \times \text{refrigerant charging amount of every 1m liquid pipe}$

Diameter of liquid pipe (mm)	Φ28.6	Φ25.4	Φ22.2	Φ19.05	Φ15.9	Φ12.7	Φ9.52	Φ6.35
kg/m	0.680	0.520	0.350	0.250	0.170	0.110	0.054	0.022

(2) \sum Refrigerant charging amount B of every module

Refrigerant charging amount B of every module(kg) ②		Module capacity(kW)							
IDU/ODU rated capacity collocation ratio C ①	Quantity of included IDUs	22.4	28.0	33.5	40.0	45.0	50.4	56.0	61.5
50% \leq C \leq 70%	<4	0	0	0	0	0	0	0	0
	\geq 4	0.5	0.5	0.5	0.5	0.5	0.5	1.0	1.5
70% $<$ C \leq 90%	<4	0.5	0.5	1	1.5	1.5	1.5	2.0	2
	\geq 4	1	1	1.5	2	2	2.5	3.0	3.5
90% $<$ C \leq 105%	<4	1	1	1.5	2	2	2.5	3.0	3.5
	\geq 4	2	2	3	3.5	3.5	4.0	4.5	5
105% $<$ C \leq 135%	<4	2	2	2.5	3	3	3.5	4	4
	\geq 4	3.5	3.5	4	5	5	5.5	6	6

For example 1:

The OUD is composed of 3 modules: AMV5-O280, AMV5-O400, and AMV5-O450.

The IDUs are made up of 8 sets of AMV5-O140.

IDU/ODU rated capacity collocation ratio $C = 140 \times 8 / (280 + 400 + 450) = 108\%$. The quantity of included IDUs is more than 4 sets. Please refer to the above table.

Refrigerant charging amount B for AMV5-O280 module is 3.5kg

Refrigerant charging amount B for AMV5-O400 module is 5.0kg

Refrigerant charging amount B for AMV5-O450 module is 5.0kg

So, \sum Refrigerant charging amount B of every module = $3.5 + 5.0 + 5.0 = 13.5\text{kg}$

Suppose the Pipeline charging amount $A = \sum \text{Liquid pipe length} \times \text{refrigerant charging amount of every 1m liquid pipe} = 25\text{kg}$

Total refrigerant charging amount $R = 25 + 13.5 = 38.5\text{kg}$

For example 2:

The outdoor unit is made up of 1 module: GMV-450WM/B-X. The indoor unit is 1 set of fresh air indoor unit: GMV-NX450P/A(X4.0)-M. In this case, the quantity (B) of refrigerant added to this module is 0kg.

So, $\sum B$ (Quantity of refrigerant added to each module) = 0kg

Suppose that A (Quantity of refrigerant added to connection pipe) = Σ Length of liquid pipe x Quantity of refrigerant added to liquid pipe per meter) = 5kg

R (Quantity of added refrigerant in total) = 5+0=5kg

After confirming that there is no leakage from the system, when the compressor is not in operation, charge additional R410A with specified amount to the unit through the filling opening of the liquid pipe valve of the outdoor unit. If required additional refrigerant can not be quickly filled for increase of pressure in the pipe, set the unit at cooling startup and then fill the refrigerant from gas valve of outdoor unit. If ambient temperature is low, the unit can't be set to cooling mode but heating mode.

4.5 Electric Wiring

4.5.1 Wiring precautions

- ◆ Wiring should conform to national rules. All the parts, materials, electric work should be in accordance with local codes.
- ◆ Rated voltage and exclusive power supply should be used.
- ◆ Power cord should be fixed soundly and reliable. Never forcibly pull the power cord.
- ◆ Wire size of power cord should be large enough. The damaged power cord and connecting wire should be replaced by exclusive cable.
- ◆ All the electrical work should be performed by professional personnel as per local law, regulation and this manual.
- ◆ Connect the unit to the special earthing device and make sure the unit is earthed soundly.
- ◆ Circuit breaker and circuit breaker is required to be set. Circuit breaker should have both magnetic trip and thermal trip functions so as to protect the unit when short-circuit and overload happens. D-type breaker is advised to be used.
- ◆ Wiring diagram attached on the unit is prevailed.

4.5.2 Wiring of power cord

Every unit should have corresponding short-circuit and overload protection. And also a main switch is required to control power supply or disconnection. See Fig.37.

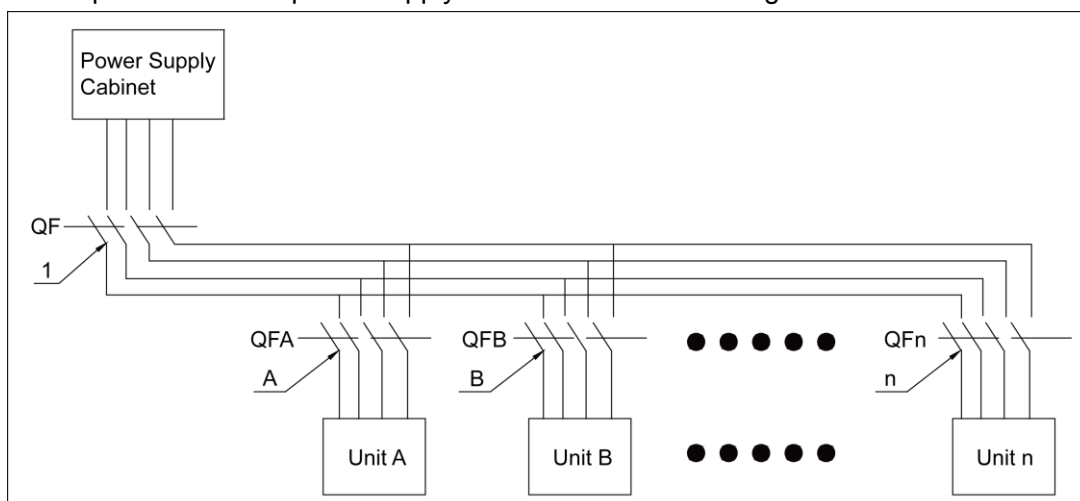

Fig.37

Please refer to the following table for circuit breaker and circuit breaker for modular outdoor units. 5-core cable is used and the wire size unit is mm².

Model	Basic models	Circuit breaker capacity (A)	Circuit breaker capacity for combined units (A)	Wire size of power supply (mm ²)	Wire size of combined uni (mm ²)
AMV5-O224	AMV5-O224	20	20	2.5	2.5×5
AMV5-O280	AMV5-O280	25	25	2.5	2.5×5
AMV5-O335	AMV5-O335	32	32	4.0	4.0×5
AMV5-O400	AMV5-O400	40	40	6.0	6.0×5
AMV5-O450	AMV5-O450	40	40	6.0	6.0×5
AMV5-O504	AMV5-O504	50	50	10	10×5
AMV5-O560	AMV5-O560	63	63	10	10×5
AMV5-O615	AMV5-O615	63	63	10	10×5
AMV5-O680	280+400	63	25 + 40	2.5 + 6.0	2.5×5 + 6.0×5
AMV5-O730	280+450	63	25 + 40	2.5 + 6.0	2.5×5 + 6.0×5
AMV5-O785	280+504	80	25 + 50	2.5 + 10	2.5×5 + 10×5
AMV5-O850	280+560	80	25 + 63	2.5 + 10	2.5×5 + 10×5
AMV5-O900	280+615	80	25 + 63	2.5 + 10	2.5×5 + 10×5
AMV5-O950	335+615	80	32 + 63	4.0 + 10	4.0×5 + 10×5
AMV5-O1010	400+615	100	40 + 63	6.0 + 10	6.0×5 + 10×5
AMV5-O1065	450+615	100	40 + 63	6.0 + 10	6.0×5 + 10×5
AMV5-O1130	504+615	125	50 + 63	10 + 10	10×5 + 10×5
AMV5-O1180	560+615	125	63 + 63	10 + 10	10×5 + 10×5
AMV5-O1235	615+615	125	63 + 63	10 + 10	10×5 + 10×5
AMV5-O1300	280+450+560	125	25 + 40 + 63	2.5 + 6.0 + 10	2.5×5 + 6.0×5 + 10×5
AMV5-O1350	280+450+615	125	25 + 40 + 63	2.5 + 6.0 + 10	2.5×5 + 6.0×5 + 10×5
AMV5-O1405	335+450+615	125	32 + 40 + 63	4.0 + 6.0 + 10	4.0×5 + 6.0×5 + 10×5
AMV5-O1456	280+560+615	160	25 + 63 + 63	2.5 + 10 + 10	2.5×5 + 10×5 + 10×5
AMV5-O1512	280+615+615	160	25 + 63 + 63	2.5 + 10 + 10	2.5×5 + 10×5 + 10×5
AMV5-O1570	335+615+615	160	32 + 63 + 63	4.0 + 10 + 10	4.0×5 + 10×5 + 10×5
AMV5-O1650	400+615+615	160	40 + 63 + 63	6.0 + 10 + 10	6.0×5 + 10×5 + 10×5
AMV5-O1700	450+615+615	160	40 + 63 + 63	6.0 + 10 + 10	6.0×5 + 10×5 + 10×5
AMV5-O1750	504+615+615	160	50 + 63 + 63	10 + 10 + 10	10×5 + 10×5 + 10×5
AMV5-O1800	560+615+615	180	63 + 63 + 63	10 + 10 + 10	10×5 + 10×5 + 10×5
AMV5-O1845	615+615+615	180	63+63+63	10+10+10	10×5+10×5+10×5
AMV5-O1908	280+450+560+615	180	25+40+63+63	2.5+6.0+10+10	2.5×5+6.0×5+10×5+10×5
AMV5-O1962	280+504+560+615	180	25+50+63+63	2.5+10+10+10	2.5×5+10×5+10×5+10×5

Model	Basic models	Circuit breaker capacity (A)	Circuit breaker capacity for combined units (A)	Wire size of power supply (mm ²)	Wire size of combined uni (mm ²)
AMV5-O2016	280+560+560+615	200	25+63+63+63	2.5+10+10+10	2.5×5+10×5+10×5+10×5
AMV5-O2072	280+ 560+615+615	200	25+63+63+63	2.5+10+10+10	2.5×5+10×5+10×5+10×5
AMV5-O2128	280+615+615+615	200	25+63+63+63	2.5+10+10+10	2.5×5+10×5+10×5+10×5
AMV5-O2184	335+615+615+ 615	200	32+63+63+63	4.0+10+10+10	4.0×5+10×5+10×5+10×5
AMV5-O2240	400+615+615+615	200	40+63+63+63	6.0+10+10+10	6.0×5+10×5+10×5+10×5
AMV5-O2295	450+615+615+615	225	40+63+63+63	6.0+10+10+10	6.0×5+10×5+10×5+10×5
AMV5-O2350	504+615+615+615	225	50+63+63+63	10+10+10+10	10×5+10×5+10×5+10×5
AMV5-O2405	560+615+615+615	225	63+63+63+63	10+10+10+10	10×5+10×5+10×5+10×5
AMV5-O2460	615+615+615+615	225	63+63+63+63	10+10+10+10	10×5+10×5+10×5+10×5

Note:“280+400”: indicates the combination of GMV-280WM/B-X and GMV-400WM/B-X unit.

Please refer to the following table for circuit breaker and circuit breaker for indoor units. Breaker listed in the table represents total capacity of breaker in one system.

Total capacity of indoor units	Capacity of circuit breaker (A)	Min. sectional area of power cord (mm ²)	Min. sectional area of grounding wire (mm ²)
Below10A	10	1.0	1.0
16~10A	16	1.5	1.5
20~16A	20	2.5	2.5
32~20A	32	4.0	4.0

Total capacity of indoor units	Capacity of circuit breaker (A)	Min. sectional area of power cord (mm ²)	Min. sectional area of grounding wire (mm ²)
40~32A	40	6.0	6.0
50~40A	50	10.0	10.0
63~50A	63	16.0	16.0
80~63A	80	25.0	16.0
100~80A	100	35.0	16.0
125~100A	125	50.0	25.0

Breaker capacity and power cord specification for every indoor unit

Indoor unit	Capacity of circuit breaker (A)	Min. sectional area of grounding wire (mm ²)	Min. sectional area of power cord (mm ²)
Wall-mounted type	6	1.0	1.0
Duct type unit (heat pump)	6	1.0	1.0
Cassette type unit (heat pump)	6	1.0	1.0
One-way cassette type unit	6	1.0	1.0

If indoor unit is equipped with auxiliary electric heater, select capacity of circuit breaker as per auxiliary electric heater, which requires special setting.

Indoor unit models (with auxiliary electric heater)	Capacity of circuit breaker (A)	Min. sectional area of grounding wire (mm ²)	Min. sectional area of power cord (mm ²)
22,25,28,32,36 duct type unit	6	1.0	1.0
40,45,50 duct type unit	10	1.0	1.0
56,63,71,80 duct type unit	16	1.5	1.5
90,100,112,25,140 duct type unit	10	1.0	1.0
28,36,45,50 cassette type unit	6	1.0	1.0
56,63,71,80 cassette type unit	10	1.0	1.0
90,112,125,140 cassette type unit	6	1.0	1.0

Note:

- ① Specification of circuit breaker and power cord is selected on the basis of unit's maximum power (max. current).
- ② Specification of power cord is based on the working condition where ambient temperature is 40°C and multi-core cable with copper conductor (working temperature is 90°C, e.g. power cable with YJV cross-linked copper, insulated PE and PVC sheath) is lying on the surface of slot. If working condition is different, please adjust the specification according to national standard.
- ③ Copper-core cable must be used.
- ④ The above sectional area is suitable for a maximum distance of 15m. If it's over 15m, sectional area must be expanded to prevent overload current from burning the wire or causing fire hazard.
- ⑤ Specification of circuit breaker is based on the working condition where the ambient temperature of circuit breaker is 40°C. If working condition is different, please adjust the specification according to national standard.
- ⑥ The circuit breaker should include magnetic trip function and thermal trip function so that system can be protected from short circuit and overload.
- ⑦ An all-pole disconnection switch having a contact separation of at least 3mm in all poles should be connected in fixed wiring

4.5.3 Connection of power cord

Warning: before obtaining access to terminals, all supply circuits must be disconnected.

Note:

- (1) If units are type I electrical appliances, they must be reliably grounded.
- (2) Ground resistance must be in accord with requirements of local standard.
- (3) The green-yellow wire within units are ground wire. Do not use it for other purposes. Nor should it be cut off or secured by tapping screws. Otherwise, it may cause electric shock.
- (4) Power supply at user side must have reliable ground terminal. Do not connect ground wire to the following places:

- 1) water pipe, 2) gas pipe, 3) drainage pipe, 4) other places that are considered by professionals as unreliable.
- (5) Power cord and communication wire should be separated, with a distance of more than 20cm. Otherwise, system's communication may not work well.

Steps and graphic of power cord connection:

- (1) Knock off the cross-through opening that's used for leading the external power cord, with the cross-through rubber ring on the opening. Then lead the cable through the opening. Connect L1, L2, L3, N of power cord and ground wire separately to the positions on wiring board (for power supply) that are marked with L1, L2, L3, N and the ground screw nearby.
- (2) Use cable ties to tie the cable securely,
- (3) Lead the power cord as instructed in the graphic below:

Wiring method for the power cord of

AMV5-O224, AMV5-O280, AMV5-O335, AMV5-O400 and AMV5-O450

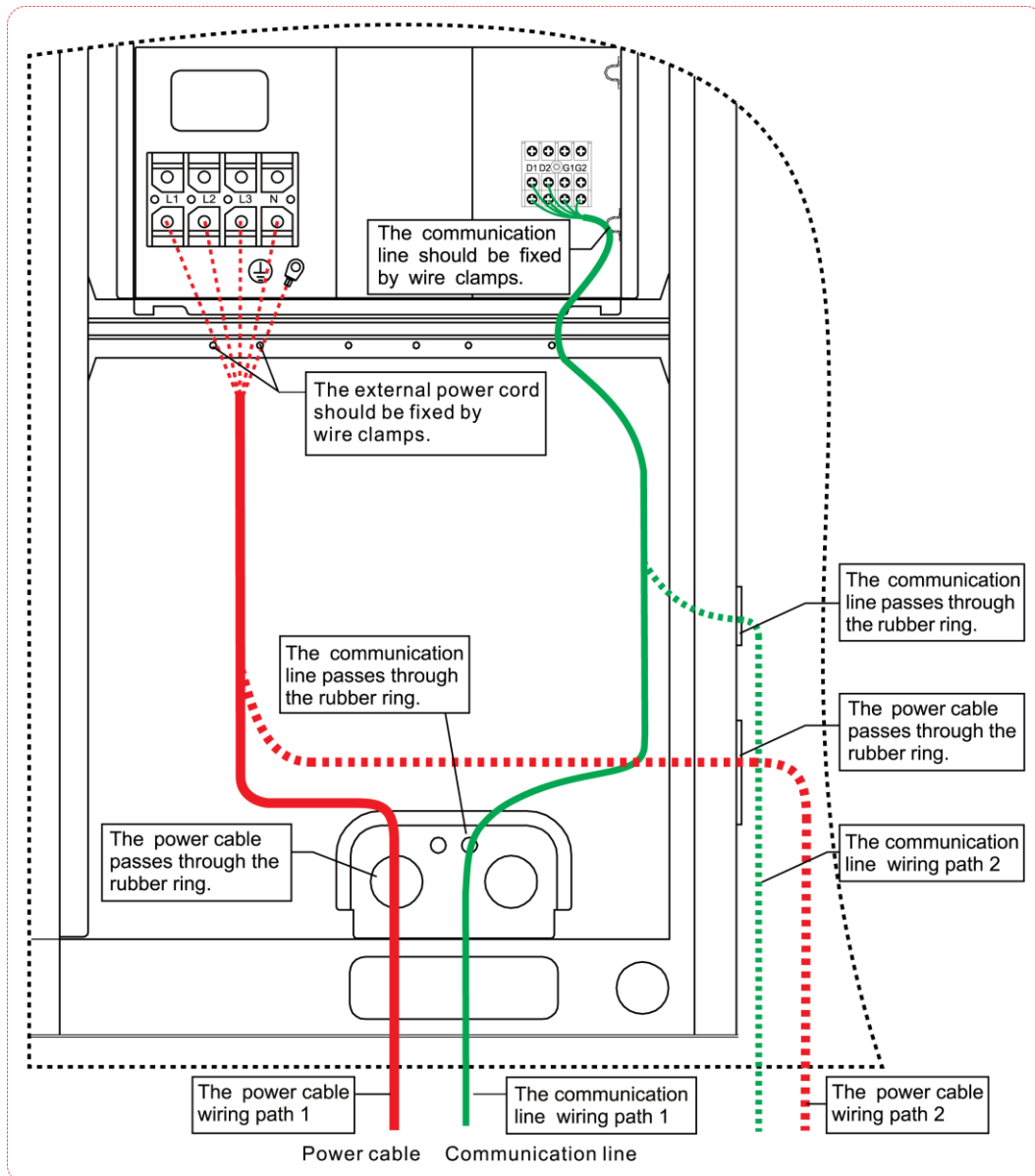

Fig.38

Wiring method for the power cord of AMV5-O504, AMV5-O560 and AMV5-O615

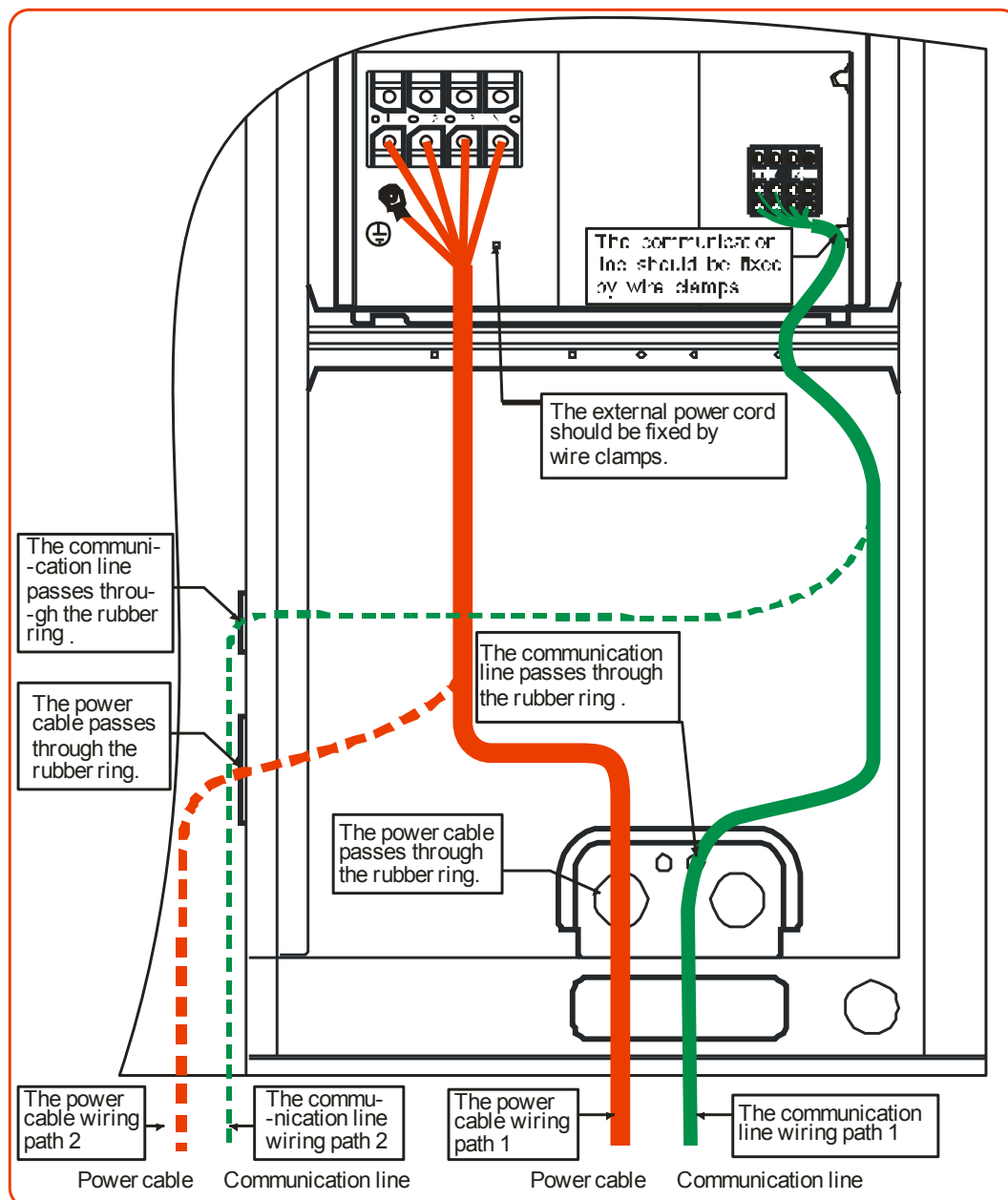

Fig.39

4.6 System Communication

4.6.1 Communication system include:

- (1) Communication among outdoor basic modules;
- (2) Communication between ODU and IDU;
- (3) Communication among IDUs;
- (4) Communication between IDU and wired controller;
- (5) Connection between IDU and light board receiver;
- (6) Communication between different refrigeration systems;
- (7) Graphics of general communication connection

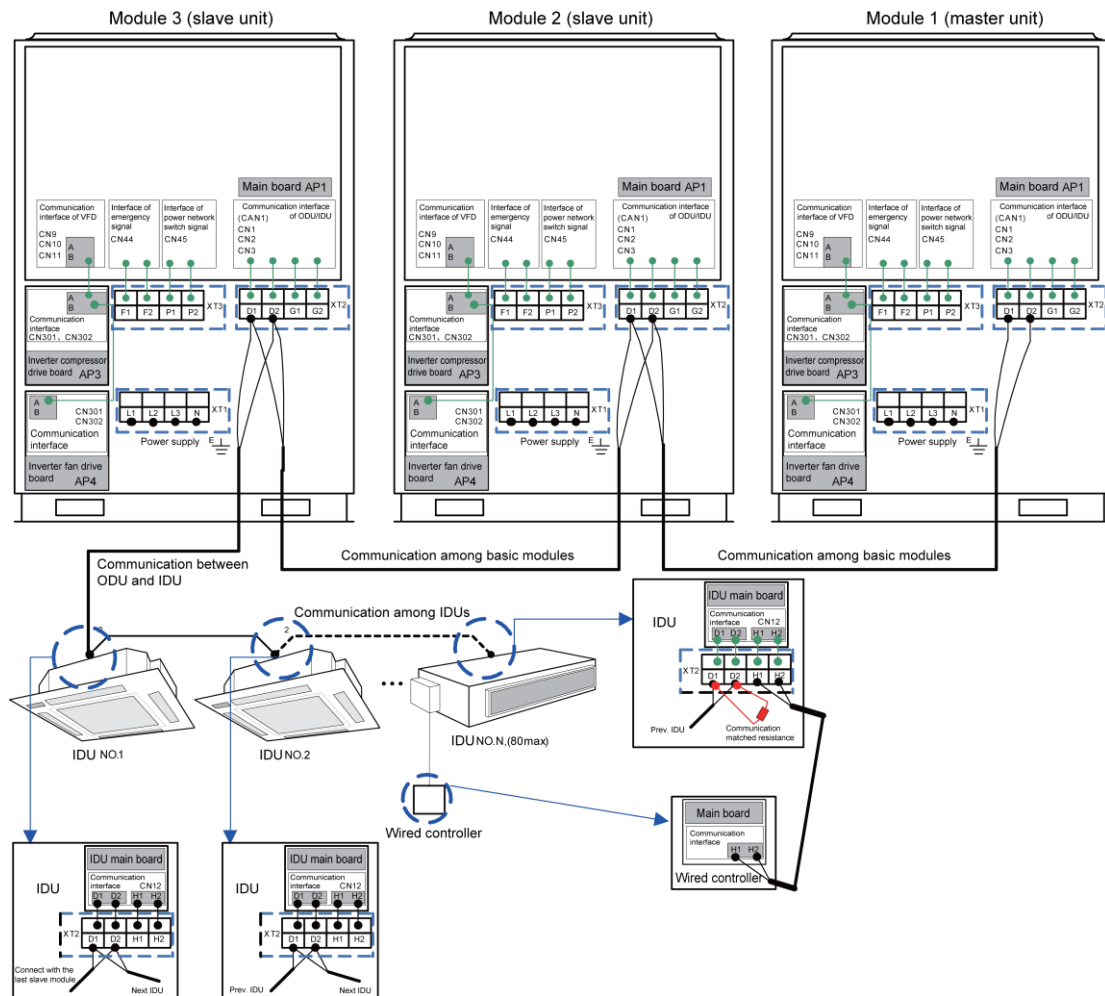

Fig.40

4.6.2 Communication mode of AMV5 Modular DC Inverter Units

CAN bus mode is taken for communication between IDU and ODU and communication among IDUs.

4.6.3 Selection and connection mode of AMV5 communication material

4.6.3.1 Select communication wire between IDU and wired controller

Note: if air conditioners are installed at places where there's strong electromagnetic interference, the communication wire of IDU and wired controller must use shielded wire and the communication wire between IDU and IDU/ODU must use shielded twisted pair.

(1) Select communication wire between IDU and wired controller

Material type	Total length of communication line between IDU unit and wired controller L (m)	Wire size (mm ²)	Material standard	Remarks

Light/Ordinary polyvinyl chloride sheathed cord. (60227 IEC 52 /60227 IEC 53)	$L \leq 250$	$2 \times 0.75 \sim 2 \times 1.25$	IEC 60227-5:2007	<ol style="list-style-type: none"> Total length of communication line can't exceed 250m. The cord shall be Circular cord (the cores shall be twisted together). If unit is installed in places with intense magnetic field or strong interference, it is necessary to use shielded wire.
---	--------------	------------------------------------	------------------	---

Graphic of connection between IDU and wired controller

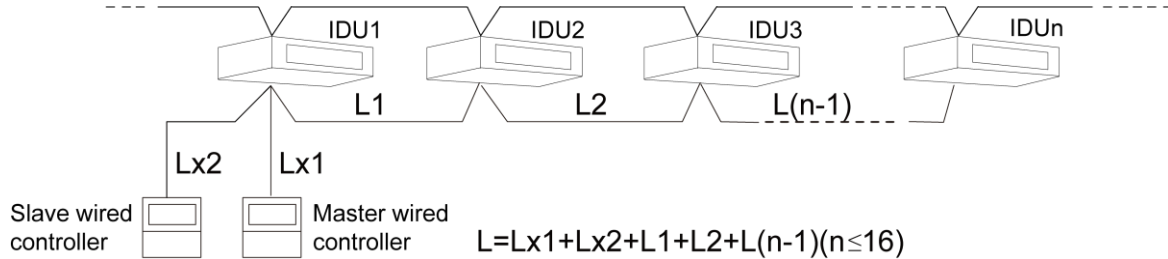

Fig.41

(2) Select communication wire between ODU and IDU

Material Type	Total Length L(m) of Communication Cable between IDU Unit and IDU (ODU) Unit	Wire size (mm ²)	Material Standard	Remarks
Light/Ordinary polyvinyl chloride sheathed cord. (60227 IEC 52 /60227 IEC 53)	$L \leq 1000$	$\geq 2 \times 0.75$	IEC 60227-5:2007	<ol style="list-style-type: none"> If the wire diameter is enlarged to $2 \times 1 \text{ mm}^2$, the total communication length can reach 1500m. The cord shall be Circular cord (the cores shall be twisted together). If unit is installed in places with intense magnetic field or strong interference, it is necessary to use shielded wire.

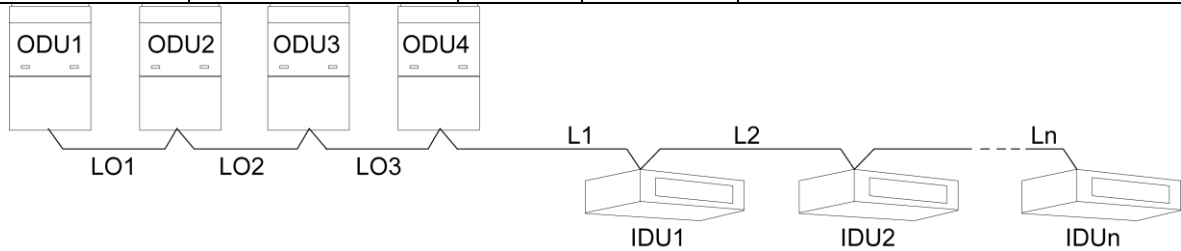

Fig.42

4.6.3.2 Connection mode of communication

(1) All communication wires of GMV5 must be connected in series rather than in star.

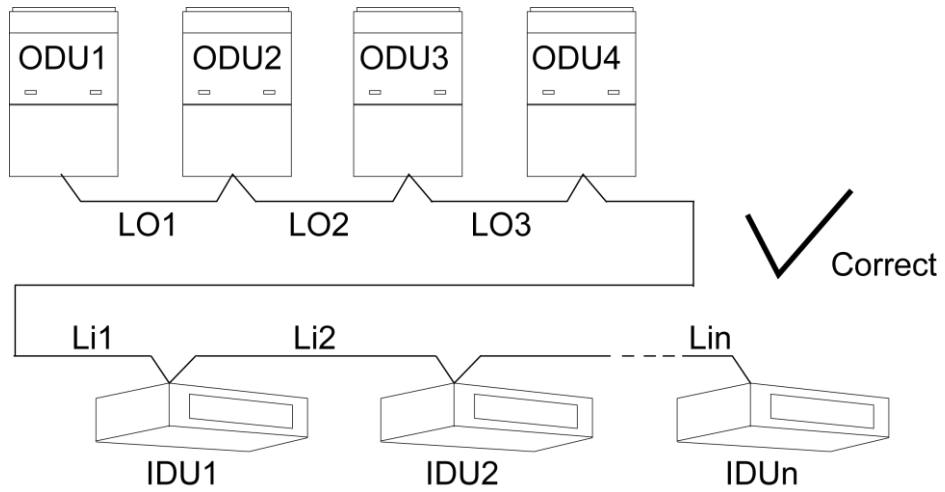

Fig.43

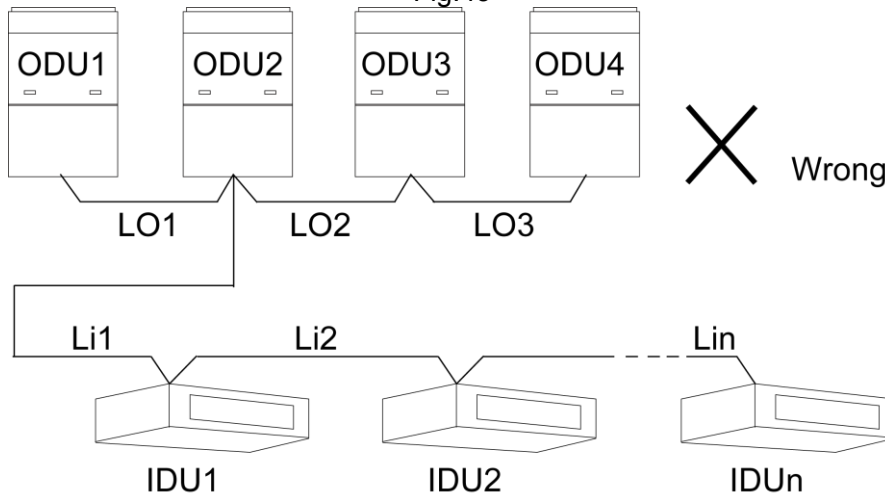

Fig.44

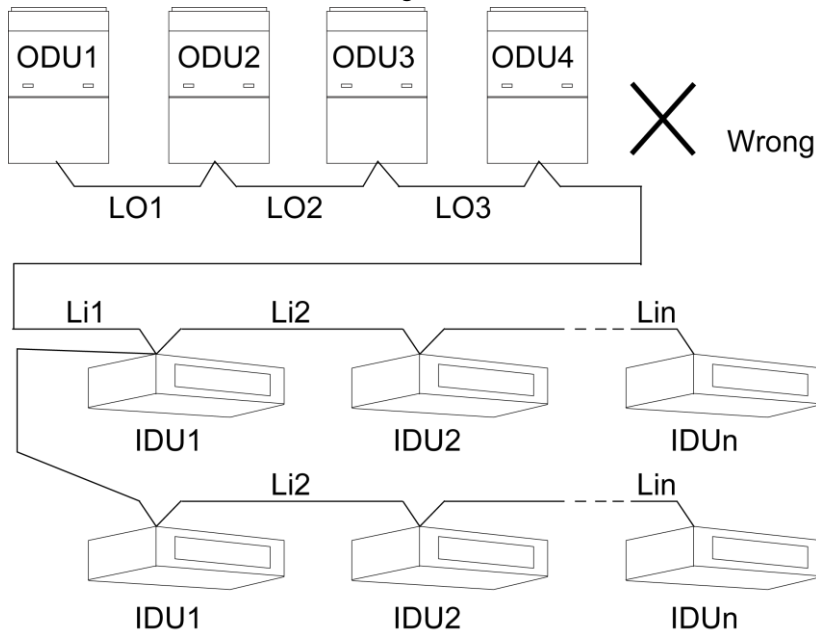

Fig.45

(2) All communication wires of AMV5 are connected by screws.

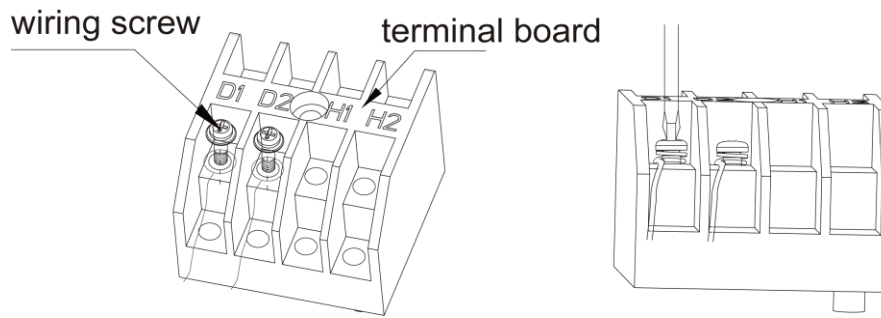

Fig.46

- (3) If a single communication wire is not long enough and needs to be connected, the connected joint must be welded or pressure-welded. Do not simply twist the wires together.

4.6.4 Communication address

Auto addressing technology is adopted for GMV5 IDU and ODU. No need to set address codes manually. Only the addresses of master unit and central control are needed to be set (address of central control is only needed when there are multiple refrigeration systems).

Note: When installing remote monitor or central controller, displacement on indoor units' project codes must be made. Otherwise, there will be collision malfunction of the project codes. For detail operation methods, please refer to **the GMV5 Installation and Maintenance Manual**.

4.7 Connection Method and Steps for System Communication

4.7.1 Communication connection between IDU and ODU

Note: The centralized controller can be installed when it is necessary.

Connect IDU and ODU via terminal D1/D2 of wiring board XT2. Below are the connection graphics of single unit and modular units:

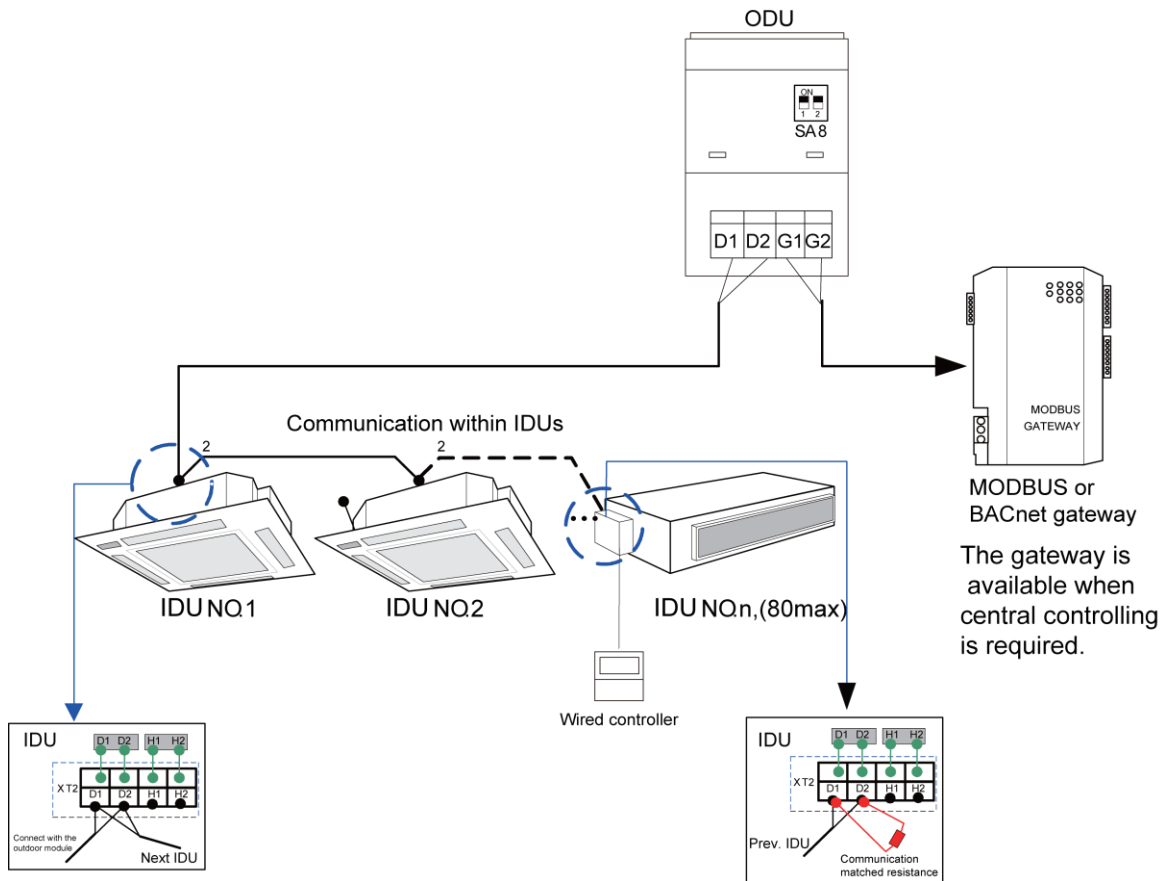

Fig.47 Connection of single unit

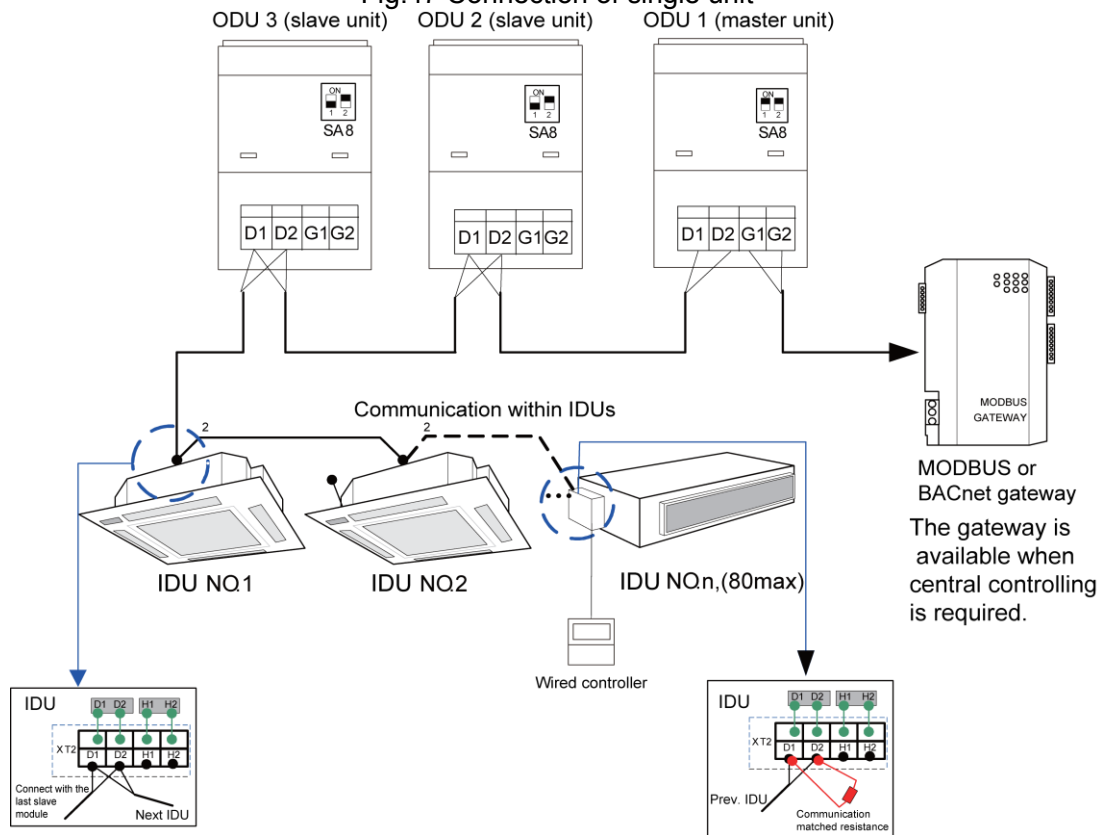

Fig.48 Connection of modular units

Note:

- ① For modular outdoor units, if there are multiple outdoor modules, then the master unit must be the first outdoor module on the communication wire and should not connect with

- IDU (master unit is set by SA8 of the outdoor main board).
- ② For modular outdoor units, if there are multiple outdoor modules, then indoor units must be connected with the last slave module of ODU (slave module is set by SA8 of the outdoor main board).
 - ③ Communication wire and power cord must be separated.
 - ④ Communication wire must be of proper length. Extension is not allowed.
 - ⑤ IDUs must be connected in series. The last IDU must be connected with the communication matched resistance (supplied in the list of ODU spare parts).

4.7.2 Communication connection between IDU and wired controller

There are 4 kinds of connection between IDU and wired controller, as shown below:

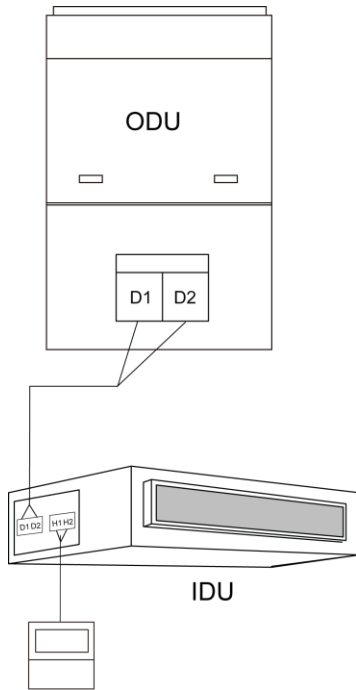

Fig.49 One wired controller controls one IDU

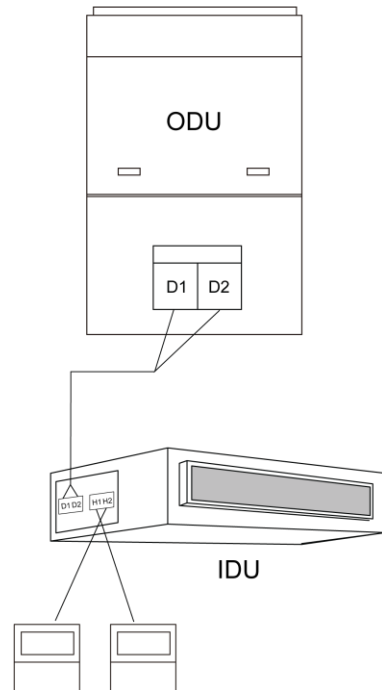

Fig.50 Two wired controllers control one IDU

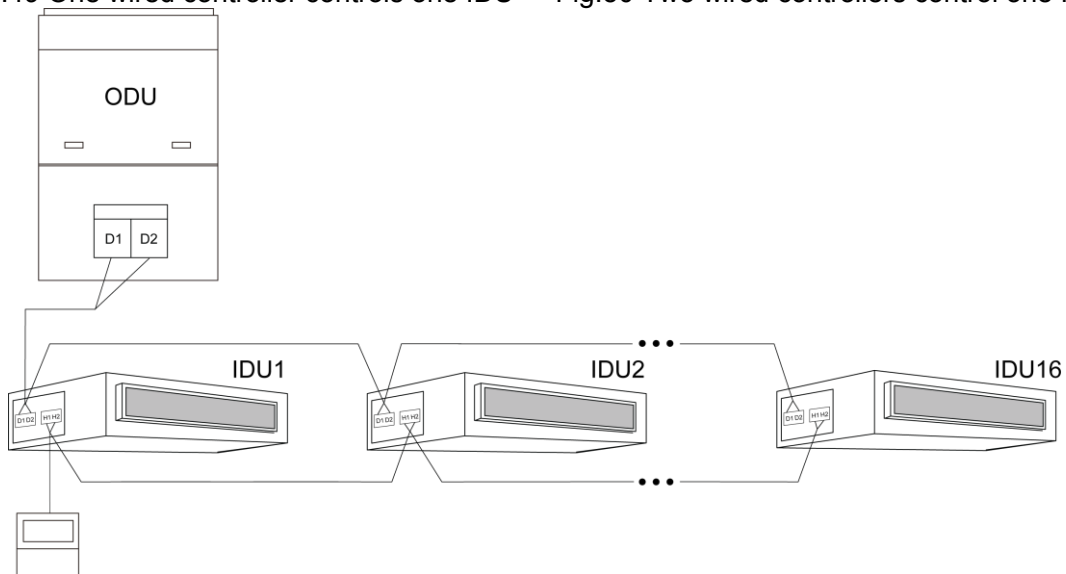

Fig.51 One wired controller controls multiple IDUs

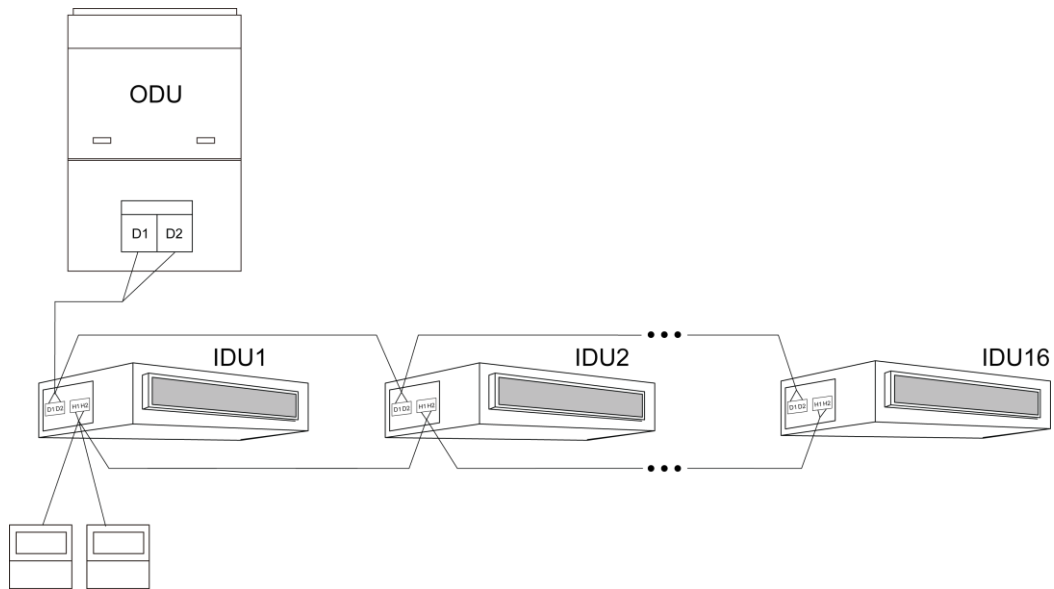

Fig.52 Two wired controllers control multiple IDUs

When two wired controllers control multiple IDUs, the wired controller can be connected to any one IDU, provided that the connected IDU is of the same series. Meanwhile, one and only one of the wired controllers must be set as a slave controller. At most 16 IDUs can be controlled by wired controllers and the connected IDUs shall be within a same IDU network.

No matter when unit is turned on or off, slave controller can be set.

How to set a slave controller: hold “function” button on the designated controller for 5s, and temperature zone displays C00. Continue holding “function” button for 5s and setting screen of controller parameter will come out. Default temperature zone displays P00.

Press ▲ button or ▼ button to select parameter code P13. Press “mode” button to switch to setup of parameter values. Then the parameter value will blink. Press ▲ button or button ▼ to select code 02. And then press “confirm/cancel” to finish setting.

Press “confirm/cancel” to return to the previous display until you exit from the setup of parameter values.

Below are user’s parameter settings:

Parameter code	Parameter name	Parameter scope	Default value	Remark
P13	Set up address for wired controller	01: master wired controller 02: slave wired controller	01	When 2 wired controllers control one or more IDUs, they shall have different addresses. Slave wired controller (02) can’t set up units’ parameters except its own address.

4.7.3 Communication connection between duct type IDU and light board receiver

When the duct type IDU needs to be connected to light board remote receiver, it can be connected via Dsp1 and Dsp2 on the IDU main board.

IDU type	Connection wire	Main board interface of corresponding IDU
Duct type IDU	Between boards (17-core)	Dsp1 (direct to 8-core interface) Dsp2 (direct to 9-core interface)

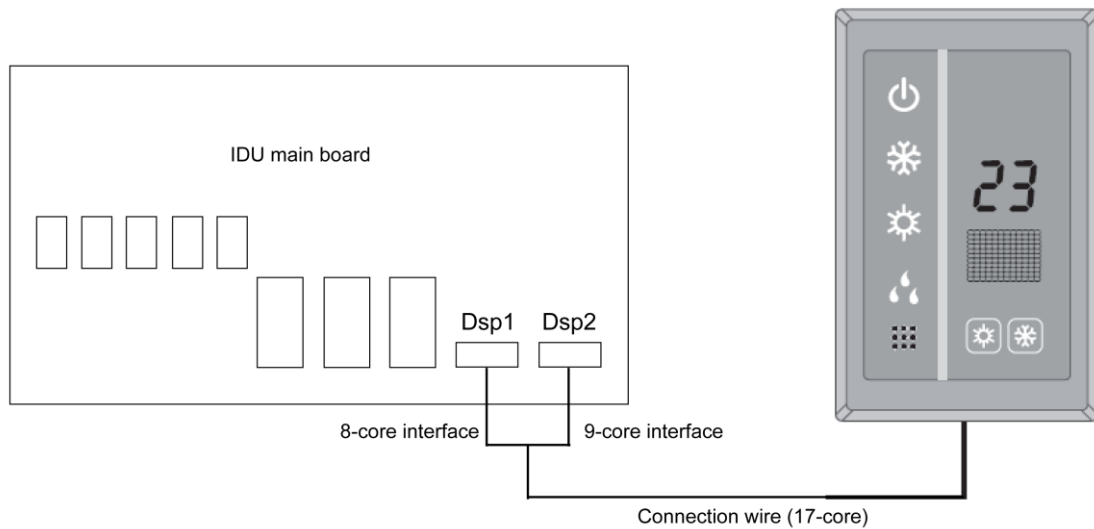

Fig.53

Note:

- ① Wired controller and light board remote receiver can be used at the same time.
- ② When light board remote receiver is used, please use remote controller at the same time.

4.7.4 Communication connection of central controlling units

Note: The centralized controller can be installed when it is necessary.

Port connection G1 and G2 on the wiring board XT2 of master unit among each multi VRF system (see below)

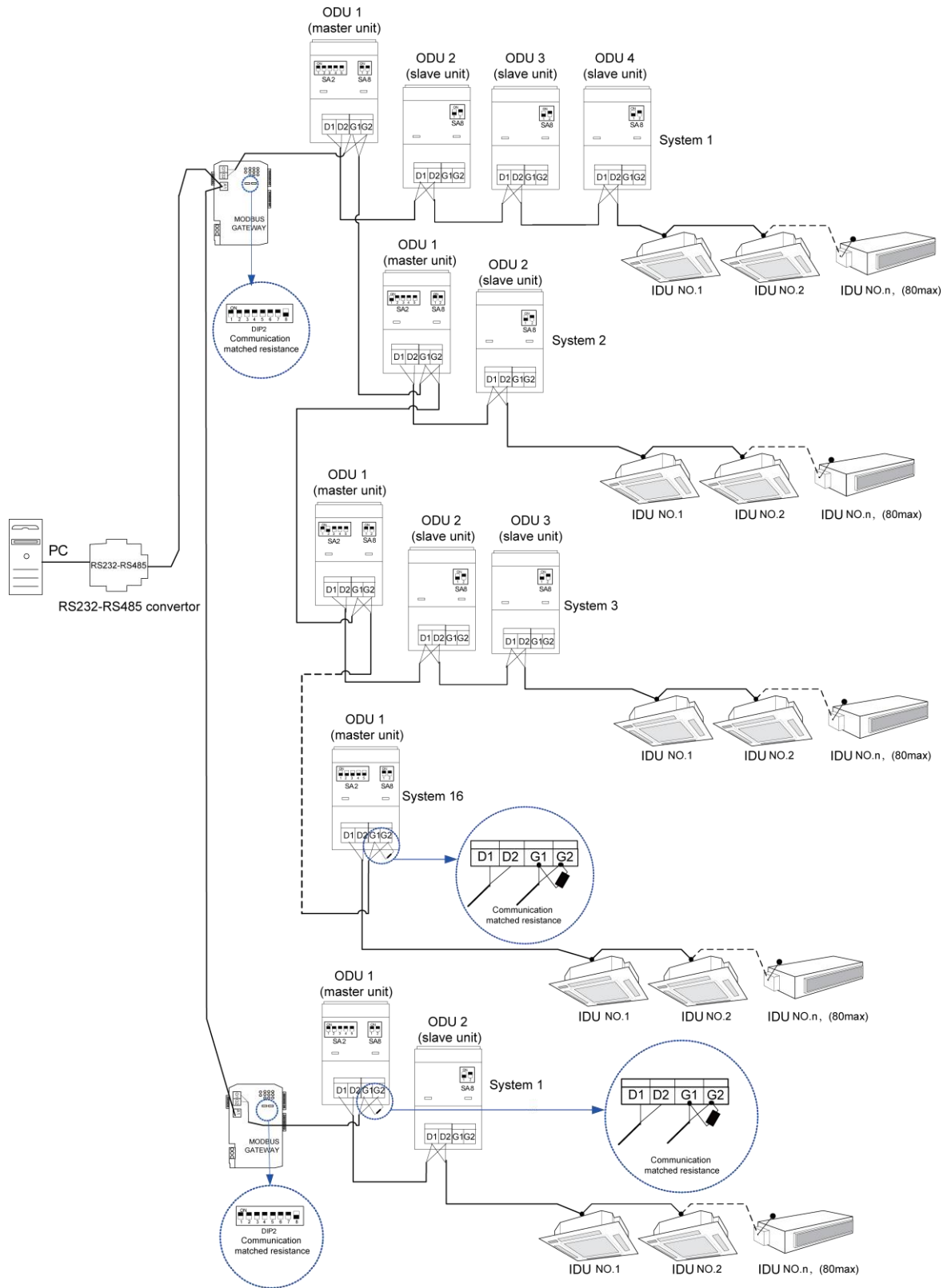

Fig.54

4.8 External Electrical Wiring Diagram

Each unit should be equipped with a circuit breaker for short circuit protection and exceptional overload protection. Besides, a main circuit breaker shall be prepared for IDUs and ODUs in order to connect or disconnect power of the entire system.

4.8.1 External wiring diagram of a single unit

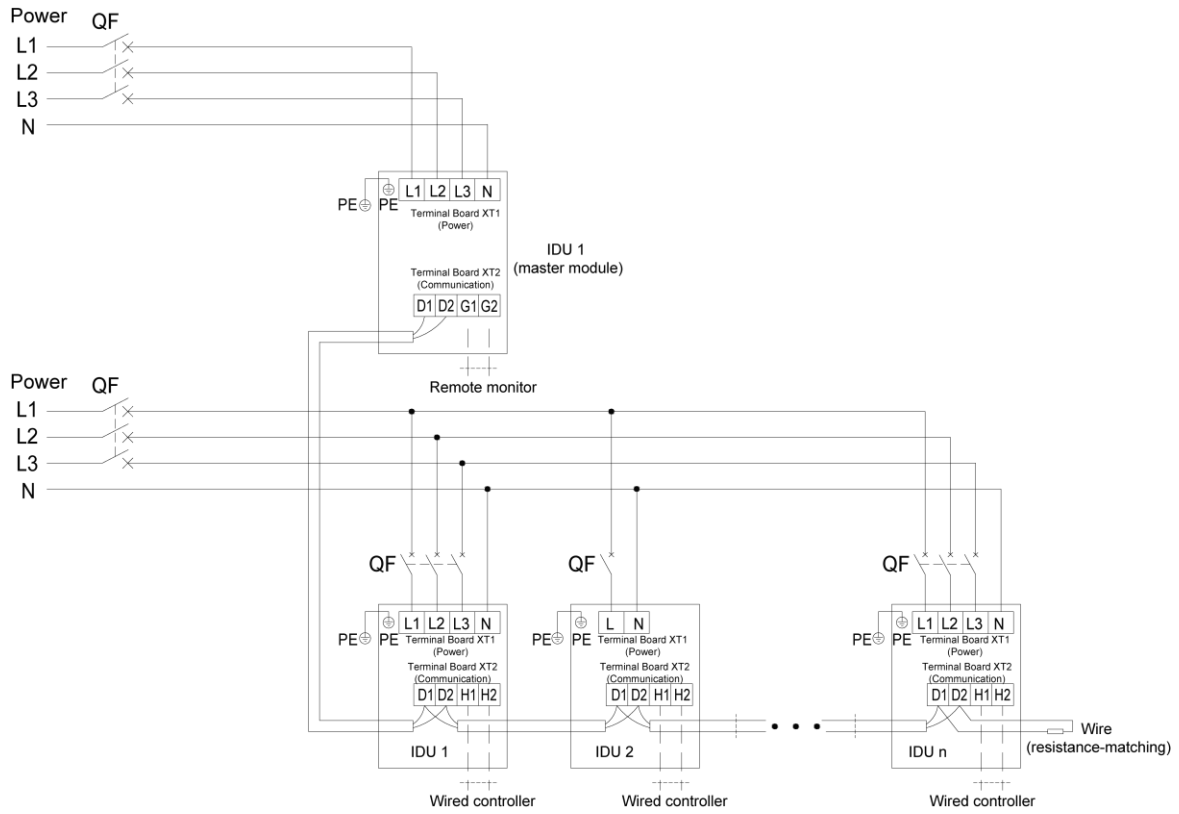

Fig.55

Note: maximum number of IDU is based upon ODU capacity. For details, please refer to the introduction of units' combination.

4.8.2 External wiring diagram of modular connection

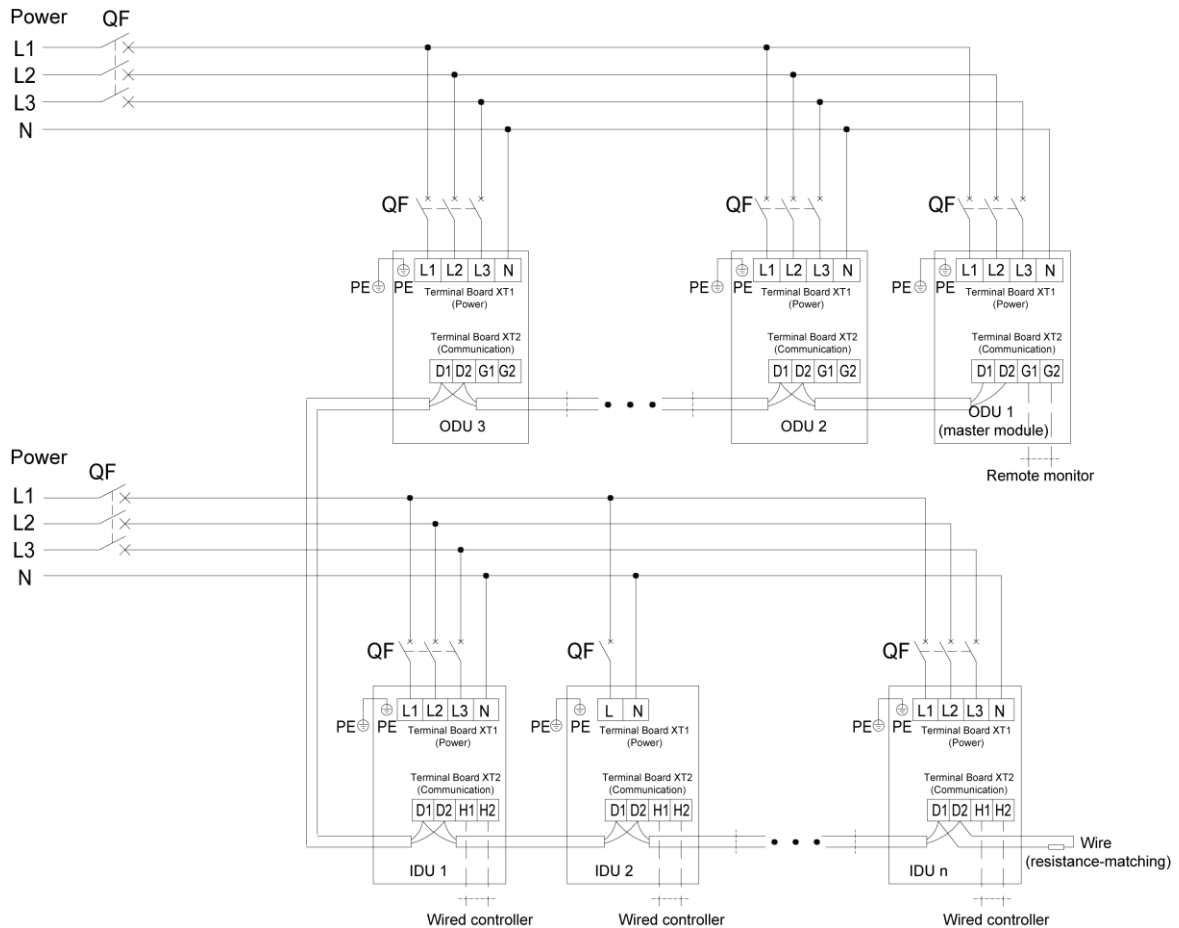

Fig.56

Note: maximum number of ODU (N) and maximum number of IDU (n) are based upon the combination type of ODU. For details, please refer to the introduction of units' combination.

5 Check Items after Installation and Trial Run

5.1 Check Items after Installation

Check Items	Conditions Might Happen	Check
Has the unit been fixed firmly?	The unit may drop, shake or emit noise.	
Have you done the gas leakage test?	It may cause insufficient cooling/heating capacity.	
Is the unit get proper thermal insulation?	It may cause condensation and dripping.	
Does the unit drain well?	It may cause condensation and dripping.	
Is the voltage in accordance with the rated voltage specified on the nameplate?	It may cause malfunction or damage the part.	
Is the electric wiring and piping connection installed correctly and securely?	It may cause malfunction or damage the part.	
Has the unit been earthed securely?	It may cause electrical leakage.	
Is the power cord specified?	It may cause malfunction or damage the part.	
Has the inlet and outlet been blocked?	It may cause insufficient cooling/heating capacity.	
Has the pipe length and refrigerant charging amount been recorded?	The refrigerant charging amount is not accurate.	
Is the address code of outdoor modules correct?	The unit can not run normally. Communication malfunction might happen.	
Is the address code of indoor units and wired controller correct?	The unit can not run normally. Communication malfunction might happen.	
Has the communication line been connected correct?	The unit can not run normally. Communication malfunction might happen.	
Is the piping connection and valve status right?	The unit can not run normally.	
Whether phase sequence of external power cord is correct or not?	Operation failure occurs or unit is damaged.	

5.2 Trial Run

Note: during debugging, one and only one module must be set as a master module.

During debugging, one and only one IDU must be set as a master IDU.

When no special requirement is needed, no need to set other functions. Unit can operate according to ex-factory settings. When special requirement is needed, please read the Service Manual or Debugging and Maintenance Manual.

5.2.1 Preparation before trial run

- (1) The power supply should be turned on only after finishing all the installation.
- (2) All the control wires and cables are connected correctly and safely. Completely open the gas and liquid valves.
- (3) All the objects like metal filing, thrum and clip should be cleared after installation.
- (4) Check if the unit appearance and piping system is damaged or not due to transportation.
- (5) Check if the terminals of electrical element is loose and the phase sequence is correct or

not.

- (6) Check the valve: For single-module unit, fully open the gas and liquid valve and close oil balance valve; For dual/three module unit, fully open the gas, liquid valve and oil balance valve.

5.2.2 Trial run

5.2.2.1 Notices

- (1) Before test operation, make sure unit is power on and compressor has been preheated for more than 8 hours. Touch the unit to check whether it's normally preheated. Start test operation after unit is normally preheated, otherwise compressor might be damaged. Debugging must be performed by professional technicians or under the guide of professional technicians.

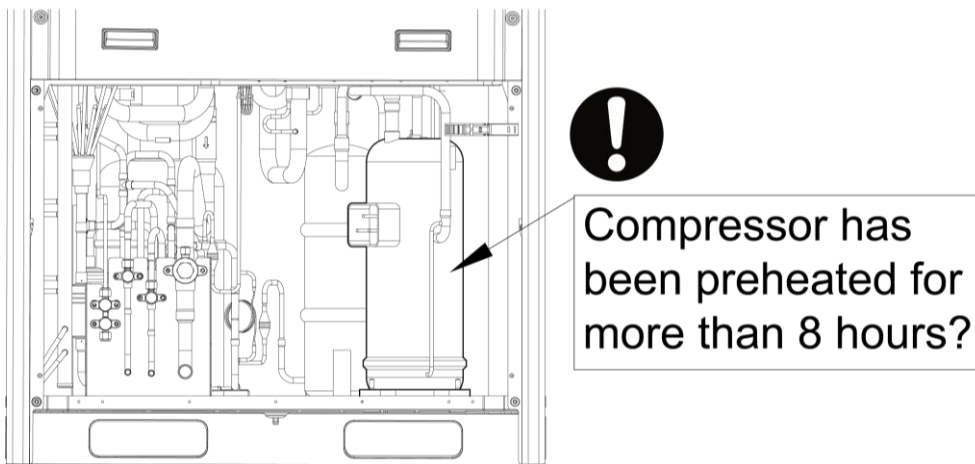

Fig.57

- (2) When debugging starts, system will operate according to the ambient temperature. When outdoor temperature is above 20°C, debugging shall be in cooling mode. When outdoor temperature is below 20°C, debugging shall be in heating mode.
- (3) Before debugging, confirm again whether the cut-off valve of each basic module is fully turned on.
- (4) During debugging, front panel of the outdoor unit must be fully closed; otherwise, debugging accuracy will be affected (see below).

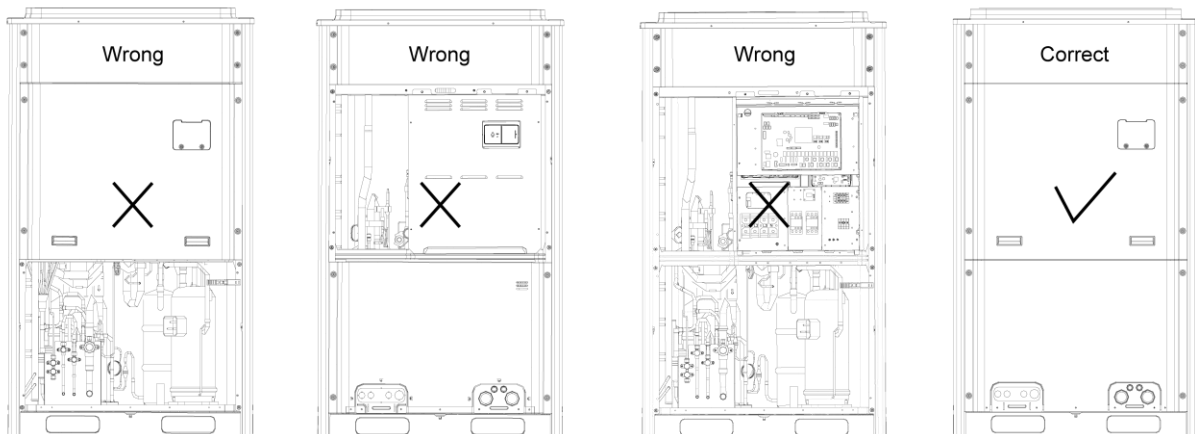

Fig.58

- (5) Before debugging, make sure the needed amount of refrigerant has been added to the

pipe or at least 70% of the needed refrigerant has been added.

(6) Description of each stage of debugging progress:

Description of each stage of debugging progress							
—	Debugging code		Progress code		Status code		Meaning
progress	LED1		LED2		LED3		
	Code	Display status	code	Display status	Code	Display status	
01_Set up master unit	db	light	01	light	A0	light	System is not debugged.
	db	light	01	light	CC	light	System doesn't have master unit. Reset master unit.
	db	light	01	light	CF	light	More than 2 master units are set. Reset master unit.
	db	light	01	light	OC	light	Master unit is successfully set. Start next progress.
Description of each stage of debugging progress							
—	Debugging code		Progress code		Status code		Meaning
progress	LED1		LED2		LED3		
	Code	Display status	code	Display status	Code	Display status	
02_Allocate addresses	db	light	02	light	Ad	blink	System is allocating addresses.
	db	light	02	light	L7	blink	Master IDU is not set. Please set master IDU. If it's not set in 1min, system will set the master IDU randomly.
	db	light	02	light	OC	light	Allocation is finished. Start next progress.
03_Confirm the quantity of modules	db	light	03	light	01~04	blink	LED3 displays the quantity of modules. Confirm the number manually.
	db	light	03	light	OC	light	System has confirmed the quantity of modules. Start next progress.
04_Confirm the quantity of IDUs	db	light	04	light	01~80	blink	LED3 displays the quantity of IDUs. Confirm the number manually.
	db	light	04	light	OC	light	System has confirmed the quantity of IDUs. Start next progress.
05_Detect internal communication	db	light	05	light	C2	light	System detects "driven communication error between master unit and inverter compressor".
	db	light	05	light	C3	light	System detects "driven communication error between master unit and inverter fan".
	db	light	05	light	CH	light	IDU/ODU "high proportion of rated capacity".
	db	light	05	light	CL	light	IDU/ODU "low proportion of rated capacity".
	db	light	05	light	OC	light	Detection is finished. Start next progress.
06_Detect outdoor	db	light	06	light	Error code	light	System detects error in outdoor components.

components	db	light	06	light	OC	light	No error in outdoor components. Start next progress.
07_Detect indoor components	db	light	07	light	XXXX/Error code	light	System detects error in indoor components. XXXX is the project no. of the faulted IDU. 3s later, relevant error code is displayed. For example, IDU no. 100 has d5 error, then LED3 displays like this: 01 (2s later) 00 (2s later) d5, and repeat again.
	db	light	07	light	OC	light	No error in indoor components. Start next progress.
08_Confirm preheated compressor	db	light	08	light	U0	light	Preheat time for compressor is less than 8h.
	db	light	08	light	OC	light	Preheat time for compressor is 8h. Start next progress.
09_Refrigerant judgments before startup	db	light	09	light	U4	light	System refrigerant is not enough. System downtime equilibrium pressure is lower than 0.3MPa.
	db	light	09	light	OC	light	System refrigerant is normal. Start next progress.
10_Status judgments of outdoor valves before startup	db	light	10	light	ON	light	Outdoor valves are being turned on.
	db	light	10	light	U6	light	Outdoor valves are not fully turned on.
	db	light	10	light	OC	light	Outdoor valves are turned on normally.
Description of each stage of debugging progress							
—	Debugging code		Progress code		Status code		Meaning
progress	LED1		LED2		LED3		
	Code	Display status	code	Display status	Code	Display status	
11_Calculate refrigerant quantity manually	db	light	11	light	AE	light	Calculate the refrigerant quantity manually and confirm the perfusion status of refrigerant (the quantity of refrigerant added into the system must be recorded accurately).
12_Confirm debugging startup	db	light	12	light	AP	blink	Ready for units to start debugging.
	db	light	12	light	AE	light	Manual calculation of refrigerant quantity is set up.
13_	—	—	—	—	—	—	no meaning.
14_	—	—	—	—	—	—	no meaning.
15_Cooling debugging	db	light	15	light	AC	light	Debugging is enabled in cooling mode (debugging mode, auto-selected by system).
	db	light	15	light	Error code	light	Error occurs during debugging in cooling mode.
	db	light	15	light	J0	light	Error of other modules occurs during debugging in cooling mode.

	db	light	15	light	U9	light	Outdoor pipeline and valves are not normal.
	db	light	15	light	XXXX/U8	light	System detects error in indoor pipeline. XXXX is the project no. of the faulted IDU. 3s later, error code U8 is displayed. For example, IDU no. 100 has U8 error, then LED3 displays like this: 01 (2s later) 00 (2s later) U8, and repeat again.
16_Heating debugging	db	light	16	light	AH	light	Debugging is enabled in heating mode (debugging mode, auto-selected by system).
	db	light	16	light	Error code	light	Error occurs during debugging in heating mode.
	db	light	16	light	J0	light	Error of other modules occurs during debugging in heating mode.
	db	light	16	light	U9	light	Outdoor pipeline and valves are not normal.
	db	light	16	light	XXXX/U8	light	System detects error in indoor pipeline. XXXX is the project no. of the faulted IDU. 3s later, error code U8 is displayed. For example, IDU no. 100 has U8 error, then LED3 displays like this: 01 (2s later) 00 (2s later) U8, and repeat again.
17_Debugging finished	01~04	light	OF	light	OF	light	Debugging is finished. System is on standby condition. LED1 displays module address. LED2 and LED3 display "OF".

5.2.2.2 Debugging operation mode

GMV5 multi VRF system has two debugging modes: one is direct operation on main board of outdoor units while the other is PC operation via special software. In PC software debugging, indoor/outdoor parameters can be displayed and historical data can be recorded and inquired. (Operation details can be found in relevant instruction manuals)

(1) Debugging through operation on main board of outdoor units

In this debugging mode, following debugging functions are included on the main board:

Step 1: front panel of the outdoor units must be fully closed. Open the debugging window of each basic module;

Step 2: disconnect power for outdoor units. According to design requirements of external static pressure, set up corresponding static pressure mode for the units. Setting methods can be seen in Outdoor Fan Static Pressure Setup SA6_ESP_S;

Step 3: disconnect power for outdoor units and set one module as a master unit. Setting methods can be seen in Master Unit Setup SA8_MASTER_S;

Step 4: Connect power for all indoor units. Make sure all IDUs are power on. Then all outdoor modules will display "Debugging not enabled";

Step 5: Find the module with "01" module address to be the master module. Hold SW7 button on the master module for at least 5s to enable debugging;

Step 6: Wait. Unit will then start progress 01 and 02; in progress 01, if master unit is not correctly set, progress 01 will show the following errors:

	Debugging	Progress Code	Status Code	Meaning
--	-----------	---------------	-------------	---------

Progress	Code						
	LED1		LED2		LED3		
	Code	Display status	Code	Display status	Code	Display status	
01_01 Set up master unit:	db	light	01	light	CC	light	System doesn't have master unit. Reset master unit.
	db	light	01	light	CF	light	More than 2 master units are set. Reset master unit.
	db	light	01	light	OC	light	Master unit is successfully set. Start next progress.

According to the above errors, reset the master unit as instructed in Master Unit Setup SA8_MASTER_S. After reset is finished, start debugging again.

In progress 02, if master IDU is not detected, then progress 02 will show the following errors:

LED1		LED2		LED3	
Function code	Display mode	Current progress	Display mode	Current status	Display mode
db	light	02	light	L7	blink

At this time, all buttons are ineffective. Set master IDU in 1min via debugging software. If master IDU is not set in 1min, system will set up a master IDU randomly. After that, system will start next progress.

Step 7: in progress 03, the quantity of modules needs to be confirmed manually. Main board of each module will display:

Progress	Debugging code		Progress code		Status code	
	LED1		LED2		LED3	
	Code	Display status	Code	Display status	Code	Display status
03_Quantity of modules	db	light	03	light	Quantity of modules	blink

If the quantity displayed is the same with actual quantity, then press SW7 confirmation button on the master unit to confirm it. Unit will start next progress:

Progress	Debugging code		Progress code		Status code	
	LED1		LED2		LED3	
	Code	Display status	Code	Display status	Code	Display status
03_Confirm the quantity of modules	db	light	03	light	OC	light

If the quantity displayed is different from actual quantity, then disconnect power and check whether communication wire among each module is correctly connected. After the check, start debugging again.

Step 8: in progress 04, the quantity of IDUs needs to be confirmed manually. Main board of each module will display:

Progress	Debugging code		Progress code		Status code	
	LED1		LED2		LED3	
	Code	Display status	Code	Display status	Code	Display status

04_Confirm the quantity of IDUs	db	Light	04	Light	Quantity of connected IDUs	blink
---------------------------------	----	-------	----	-------	----------------------------	-------

If the quantity displayed is the same with actual quantity, then press SW7 confirmation button on the master unit to confirm it. Unit will start next progress:

Progress	Debugging code		Progress code		Status code	
	LED1		LED2		LED3	
	Code	Display status	Code	Display status	Code	Display status
04_Confirm the quantity of IDUs	db	Light	04	Light	OC	Light

Step 9: progress 05 is “Detect internal communication”

If no error is detected, system will display as below and then start next progress.

—	Debugging code		Progress code		Status code		Meaning
progress	LED1		LED2		LED3		
	Code	Display status	code	Display status	Code	Display status	
05_Detect internal communication	db	Light	05	Light	OC	Light	Detection is finished. Start next progress.

If error is detected, system will stay at current progress. Error has to be solved manually.

Below are relevant errors:

—	Debugging code		Progress code		Status code		Meaning
progress	LED1		LED2		LED3		
	Code	Display status	code	Display status	Code	Display status	
05_Detect internal communication	db	Light	05	Light	C2	Light	System detects “driven communication error between master unit and inverter compressor”.
	db	Light	05	Light	C3	Light	System detects “driven communication error between master unit and inverter fan”.
	db	Light	05	Light	CH	Light	IDU/ODU “high proportion of rated capacity”.
	db	Light	05	Light	CL	Light	IDU/ODU “low proportion of rated capacity”.

Elimination methods of above errors can be found in Troubleshooting.

Step 10: progress 06 is “Detect outdoor components”

If no error is detected, system will display as below and then start next progress.

—	Debugging code		Progress code		Status code		Meaning
progress	LED1		LED2		LED3		
	Code	Display status	code	Display status	Code	Display status	
06_Detect outdoor components	db	Light	06	Light	OC	Light	No error is detected in outdoor components. Start next progress.

If error is detected, system will stay at current progress. Error has to be solved manually.

Below is relevant error:

—	Debugging code		Progress code		Status code		Meaning
progress	LED1		LED2		LED3		
	Code	Display status	code	Display status	Code	Display status	
06_Detect outdoor components	db	Light	06	Light	Error code	Light	System detects error in outdoor components.

Elimination methods of above error can be found in Troubleshooting.

Step11: progress 07 is “Detect indoor components”

If no error is detected, system will display as below and then start next progress.

—	Debugging code		Progress code		Status code		Meaning
progress	LED1		LED2		LED3		
	Code	Display status	code	Display status	Code	Display status	
07_Detect indoor components	db	Light	07	Light	OC	Light	No error is detected in indoor components. Start next progress.

If error is detected, system will stay at current progress. Error has to be solved manually.

Below is relevant error:

—	Debugging code		Progress code		Status code		Meaning
progress	LED1		LED2		LED3		
	Code	Display status	code	Display status	Code	Display status	
07_Detect indoor components	db	Light	07	Light	XXXXor Error code	Light	System detects error in indoor components.

XXXX is the project no. of the faulted IDU. 3s later, relevant error code is displayed. For example, IDU no. 100 has d5 error, then LED3 displays like this: 01 (2s later) 00 (2s later) d5, and repeat again.

Elimination methods of above error can be found in Troubleshooting.

Step 12: progress 08 is “Confirm preheated compressor”

If more than 8h of preheat time is detected, system will display as below and start next progress.

—	Debugging code		Progress code		Status code		Meaning
progress	LED1		LED2		LED3		
	Code	Display status	code	Display status	Code	Display status	
08_Confirm preheated compressor	db	Light	08	Light	OC	Light	Preheat time for compressor is 8h. Start next progress.

If less than 8h of preheat time is detected, system will give error alarm and display as below. Then press SW7 confirmation button to skip the wait time and start next progress. But this will cause force start of the compressor, which may damage the compressor.

—	Debugging code		Progress code		Status code		Meaning
progress	LED1		LED2		LED3		
	Code	Display status	code	Display status	Code	Display status	
08_Confirm preheated compressor	db	Light	08	Light	UO	Light	Preheat time for compressor is less than 8h.

Step 13: progress 09 is “Refrigerant judgments before startup”

If the refrigerant quantity inside the system meets the requirement of operation startup, system will display as below and start next progress.

—	Debugging code		Progress code		Status code		Meaning
progress	LED1		LED2		LED3		
	Code	Display status	code	Display status	Code	Display status	
09_Refrigerant judgments before startup	db	Light	09	Light	OC	Light	System refrigerant is normal. Start next progress.

If there's no or not enough refrigerant in the system to meet the requirement of operation startup, system will display U4 “refrigerant shortage protection” and fails to start next progress. Then check if there's any leakage or add refrigerant inside until error eliminated.

—	Debugging code		Progress code		Status code		Meaning
progress	LED1		LED2		LED3		
	Code	Display status	code	Display status	Code	Display status	
09_Refrigerant judgments before startup	db	Light	09	Light	O4	Light	System refrigerant is not enough. System downtime equilibrium pressure is lower than 0.3MPa.

Step 14: progress 10 is “Status judgments of outdoor valves before startup”

If master unit displays below, status judgments are enabled.

—	Debugging code		Progress code		Status code		Meaning
progress	LED1		LED2		LED3		
	Code	Display status	code	Display status	Code	Display status	
10_Status judgments of outdoor valves before startup	db	Light	10	Light	ON	Light	Outdoor valves are being turned on.

If unit detects that valve status is not normal, it will display as below:

—	Debugging code		Progress code		Status code		Meaning
progress	LED1		LED2		LED3		
	Code	Display status	code	Display status	Code	Display status	

10_Status judgments of outdoor valves before startup	db	Light	10	Light	U6	Light	Outdoor valves are not fully turned on.
--	----	-------	----	-------	----	-------	---

Then check the big and small valves whether they are fully turned on. After the check, press SW6 return button to restart the judgments.

If unit detects that valve status is normal, it will display as below and start next progress.

—	Debugging code		Progress code		Status code		Meaning
progress	LED1		LED2		LED3		
	Code	Display status	code	Display status	Code	Display status	
10_Status judgments of outdoor valves before startup	db	Light	10	Light	OC	Light	Outdoor valves are turned on normally.

Step 15: progress 11 is “Calculate refrigerant quantity manually”

No need to operate. System will start next progress.

Step 16: progress 12 is “Confirm debugging startup”

In order to make sure all preparation work is done before startup, this step is designed for user to confirm the startup again. Operate as below:

If master unit displays as below, system is waiting for confirmation signal.

—	Debugging code		Progress code		Status code		Meaning
progress	LED1		LED2		LED3		
	Code	Display status	code	Display status	Code	Display status	
12_Status judgments of outdoor valves before startup	db	Light	12	Light	AP	Blink	Ready for units to start debugging.

If it's confirmed, press SW7 confirmation button. Unit will display as below and start next progress.

—	Debugging code		Progress code		Status code		Meaning
progress	LED1		LED2		LED3		
	Code	Display status	code	Display status	Code	Display status	
12_Status judgments of outdoor valves before startup	db	Light	12	Light	AE	Light	Manual calculation of refrigerant quantity is set up.

Step 17: after unit is confirmed to start debugging, system select cooling/heating mode according to ambient temperature.

A If cooling mode is selected, relevant display is as below:

—	Debugging code	Progress code	Status code	Meaning
---	----------------	---------------	-------------	---------

progress	LED1		LED2		LED3		
	Code	Display status	code	Display status	Code	Display status	
15_Cooling debugging	db	Light	15	Light	AC	Light	Debugging is enabled in cooling mode (debugging mode, auto-selected by system).
	db	Light	15	Light	Error code	Light	Error occurs during debugging in cooling mode.
	db	Light	15	Light	J0	Light	Error of other modules occurs during debugging in cooling mode.
	db	Light	15	Light	U9	Light	Outdoor pipeline and valves are not normal.
	db	Light	15	Light	XXXX/U8	Light	System detects error in indoor pipeline. XXXX is the project no. of the faulted IDU. 3s later, error code U8 is displayed. For example, IDU no. 100 has U8 error, then LED3 displays like this: 01 (2s later) 00 (2s later) U8, and repeat again.

B If heating mode is selected, relevant display is as below:

—	Debugging code		Progress code		Status code		Meaning
progress	LED1		LED2		LED3		
	Code	Display status	code	Display status	Code	Display status	
16_Heating debugging	db	Light	16	Light	AE	Light	Debugging is enabled in heating mode (debugging mode, auto-selected by system).
	db	Light	16	Light	Error code	Light	Error occurs during debugging in heating mode.
	db	Light	16	Light	J0	Light	Error of other modules occurs during debugging in heating mode.
	db	Light	16	Light	U9	Light	Outdoor pipeline and valves are not normal.
	db	Light	16	Light	XXXX/U8	Light	System detects error in indoor pipeline. XXXX is the project no. of the faulted IDU. 3s later, error code U8 is displayed. For example, IDU no. 100 has U8 error, then LED3 displays like this: 01 (2s later) 00 (2s later) U8, and repeat again.

Step 18: if there's no error during operation for about 40min, system will automatically confirm that debugging is finished and then stop. System resumes standby condition and displays as below:

—	Debugging code		Progress code		Status code		Meaning
progress	LED1		LED2		LED3		
	Code	Display status	code	Display status	Code	Display status	

17_Debugging finished	01-04	Light	OF	Light	OF	Light	Debugging is finished. System is on standby condition. LED1 displays module address. LED2 and LED3 display "OF".
-----------------------	-------	-------	----	-------	----	-------	--

Step 19: after debugging is finished, some functions can be set up according to project's actual needs. For specific details, please refer to System Functions Setup. If no special requirements, skip this step.

Step 20: deliver the product to user and inform user about usage precautions.

5.2.3 Appendix: judgment reference of normal operational parameters

Reference of Debug Parameters of GMV5 DC Inverter Multi VRF System				
No.	Debug item	Parameter name	Unit	Reference
1	System parameters	Outdoor ambient temp	°C	—
2		Discharge tube temp of inverter compressor 1	°C	<ul style="list-style-type: none"> When system compressor starts up, temp of discharge tube or casing top in cooling mode is within 70~95°C, and at least 10°C higher than system high pressure saturation temp; Temp in heating mode is within 65°C~80°C, and at least 10°C higher than system high pressure saturation temp. When inverter compressor starts but inverter compressor 2 stops, the discharge tube temperature of inverter compressor 2 is almost the same with ambient temp.
3		Casing top temp of inverter compressor 1	°C	
4		Discharge tube temp of inverter compressor 2	°C	
5		Casing top temp of inverter compressor 2	°C	
6		Defrost temp 1	°C	
7		System high pressure	°C	<ul style="list-style-type: none"> System's normal high pressure value is within 20°C ~25°C. According to the change in ambient temp and system operational capacity, system's high pressure value is 10~40°C higher than ambient temp. The higher ambient temp is, the smaller temp difference is. When ambient temp is 25~35°C, system's high pressure value in cooling mode is 44~53°C. When ambient temp is -5~10°C, system's high pressure value in heating mode is 40~52°C.
8		System low pressure	°C	<ul style="list-style-type: none"> When ambient temp is 25~35°C, system's low pressure value in cooling mode is 0~8°C. When ambient temp is -5~10°C, system's low pressure value in heating mode is -15~5°C.
9		Opening angle of heating EXV	PLS	<ul style="list-style-type: none"> In cooling mode, heating electronic expansion valve remains 480PLS. In heating mode, the opening angle of adjustable electronic expansion valve varies within 120~480PLS.
10		Operating freq. of inverter compressor 1	Hz	Varies from 20Hz to 95Hz
11		Current of inverter compressor 1	A	<ul style="list-style-type: none"> According to different operating freq. and different load, current will vary from 7A to 25A.
12		IPM temp of inverter compressor 1	°C	<ul style="list-style-type: none"> When ambient temp is lower than 35°C, IPM temp is below 80°C. Highest temp won't be above 95°C.

13		Inverter compressor 1 driven bus voltage	V	●Normal bus voltage is 1.414 times of power voltage. For example, if 3-phase power voltage is 390v, then the bus voltage after rectification is: 390v X 1.414=551v. It's normal if actual voltage varies 15v from the calculated voltage.
14		Operating freq. of inverter compressor 2	Hz	Varies from 30Hz to 100Hz
15		Current of inverter compressor 2	A	●According to different operating freq. and different load, current will vary from 7A to 20A.
16		IPM temp of inverter compressor 2	°C	●When ambient temp is lower than 35°C, IPM temp is below 80°C. Highest temp won't be above 95°C.
17		Inverter compressor 2 driven bus voltage	V	●Normal bus voltage is 1.414 times of power voltage. For example, if 3-phase power voltage is 390v, then the bus voltage after rectification is: 390v X 1.414=551v. It's normal if actual voltage varies 15v from the calculated voltage.

Reference of Debug Parameters of GMV5 DC Inverter Multi VRF System					
No.	Debug item	Parameter name	Unit	Reference	
18	System parameters	ODU	Operating freq of fan motor 1	Hz	Adjusts in 0~65Hz according to system pressure.
19			Current of fan motor 1	A	
20			Operating freq of fan motor 2	Hz	●Adjusts in 0~65Hz according to system pressure.
21			Current of fan motor 2	A	
22		IDU	Ambient temp of IDU	°C	—
23			Inlet tube temp of indoor heat exchanger	°C	●According to different ambient temp, for a same IDU under cooling mode, inlet tube temp will be 1 ~7°C lower than outlet tube temp.
24			Outlet tube temp of indoor heat exchanger	°C	●For a same IDU under heating mode, inlet tube temp will be 10 ~20°C lower than outlet tube temp.
25			Opening angle of indoor EXV	PLS	Adjusts opening angle automatically in 200~2000PLS.
26	Communication parameter	Communication data	—	●Quantity of IDU and ODU detected by software is the same with actual quantity. No communication error.	
27	Drainage system	—	—	●IDU can drain water out completely and smoothly. Condensate pipe has no backward slope of water. Water of ODU can be drained completely through drainage pipe. No water drop from unit base.	
28	Others	—	°C	●Compressor and indoor/outdoor fan motor has no strange noise. Unit operates normally.	

6 Common Malfunction and Troubleshooting

Check the following items before contacting for repair.

Phenomenon	Reason	Measure
The unit doesn't run.	Without power supply	Connect to power supply
	Voltage is too low	Check if the voltage is within rating range

	Broken fuse or breaker trips off	Replace fuse or connect breaker
	Insufficient energy of remote controller	Replace new battery
	Remote controller is out of control scope	Control scope is within 8m
Unit runs but stop immediately	Air intake or outlet of indoor or outdoor unit is blocked	Remove obstruction
Abnormal cooling or heating	Air intake or outlet of indoor or outdoor unit is blocked	Remove obstruction
	Improper temperature setting	Adjust setting at wireless remote controller or wired controller
	Fan speed is set too low	Adjust setting at wireless remote controller or wired controller
	Wind direction is not correct	Adjust setting at wireless remote controller or wired controller
	Door or windows are opened	Close the door or windows
	Direct sunshine	Draw curtain or louver
	Too many people in the room	
	Too many heat resources in the room	Reduce heat resources
	Filter is blocked for dirt	Clean the filter

Note:

- ①When installing remote monitor or central controller, displacement on indoor units' project codes must be made. Otherwise, there will be collision malfunction of the project codes. For detail operation methods, please refer to the GMV5 Installation and Maintenance Manual.
- ②If problem can not be solved after checking the above items, please contact Gree service center and show phenomena and models.

Following circumstance are not malfunction.

"Malfunction"		Reason
Unit doesn't run	When unit is started immediately after it is just turned off	Overload protection switch makes it run after 3 minutes delay
	When power is turned on	Standby operating for about 1 minute
Mist comes from the unit	Under cooling	Indoor high humidity air is cooled rapidly
Noise is emitted	Slight cracking sound is heard when just turned on	It is noise when electronic expansion valve initialization
	There is consecutive sound when cooling	That's sound for gas refrigerant flowing in unit
	There is sound when unit starts or stops	That's sound for gas refrigerant stops to flow
	There is slight and consecutive sound when unit is running or after running	That's sound for operation of drainage system
	Cracking sound is heard when unit is operating and after operating	That's sound caused by expansion of panel and other parts due to temperature change
The unit blows out duct	When unit runs after no operation for a long period	Dust in indoor unit is blew out

The unit emits odor	Operating	The room odor absorbed by the unit is blew out again
Indoor unit still runs after switch off	After every indoor unit receive "stop" signal, fan will keep running	Indoor fan motor will keep running 20-70s so as to take good use of excess cooling and heating and prepare for next operation
Mode conflict	COOL or HEAT mode can not be operated	When the indoor operating mode conflicts with that of outdoor unit, indoor fault indicator will flash and conflict will be shown on the wired controller after 5 minutes. Indoor unit stops to run and meanwhile change outdoor operating mode as the same as that of indoor unit, then the unit will go back to normal. COOL mode doesn't conflict with DRY mode. FAN mode doesn't conflict with any mode.

7 Error Indication

Inquiry method of malfunction display: combine division number and content number to check the corresponding malfunction.

For example, division number L and content number 4 together means power supply over-current protection.

Distinguish symbol		Content symbol	0	1	2	3	4	5
Indoor	L	Malfunction of IDU (unified)	Indoor fan Protection	Auxiliary heating protection	Water overflow protection	Overcurrent protection	Free prevention protection	
	d	—	Indoor PCB is poor	—	Malfunction of ambient temperature sensor	Malfunction of indoor coil inlet temperature sensor	Malfunction of indoor mid-coil temperature sensor	
Outdoor	E	Malfunction of ODU (unified)	High-pressure protection	Low discharge temperature protection	Low-pressure protection	High discharge temperature protection of compressor	High discharge temperature protection of compressor 1	
	F	Main board of outdoor unit is poor	Malfunction of high-pressure sensor	—	Malfunction of low-pressure sensor	—	Malfunction of discharge temperature sensor of compressor 1	
	J	Other module protection	Overcurrent protection of compressor 1	Overcurrent protection of compressor 2	Overcurrent protection of compressor 3	Overcurrent protection of compressor 4	Overcurrent protection of compressor 5	
	b	—	Malfunction of outdoor ambient temperature sensor	Malfunction of defrosting temperature sensor 1	Malfunction of defrosting temperature sensor 2	Malfunction of condenser temperature sensor	Malfunction of condenser temperature sensor	
	P	Malfunction of driving board of compressor (unified)	Driving board of compressor operates abnormally	Voltage protection of driving board of compressor	Reset protection of driving module of compressor	—	Overcurrent protection of inverter compressor	
	H	Malfunction of driving board of fan(unified)	Driving board of fan operates abnormally	Voltage protection of driving board of fan	Reset protection of driving module of fan	—	Overcurrent protection of inverter fan	
Debugging	U	Preheat time of compressor is insufficient	—	Wrong setting of outdoor unit's capacity code/jumper cap	Phase sequence protection of power	Refrigerant-lacking protection	Wrong address for driving board of compressor	
	C	Communication malfunction between indoor unit and outdoor unit, indoor unit's wires controller	—	Communication malfunction between main control and inverter compressor driver	Communication malfunction between main control and inverter fan driver	Malfunction of lacking of indoor unit	Project series No. of indoor unit is shocking	
Status	A	Debugging of unit	—	Refrigerant-recovery operation of after-sales	Defrosting	Oil-return	—	
	n	SE operation setting of system	—	—	—	Limit setting for max. capacity/output capacity	—	

Distinguish symbol		Content symbol	6	7	8	9	A	H
Indoor	L	Mode conflict	Mode conflict	o master IDU	Lack of power supply	For single control over multiple units, IDU no. is not correct.	For single control over multiple units, IDU series is not correct	Alarm because the air quality is bad
	d	Malfunction of indoor coil temperature sensor	Malfunction of indoor coil temperature sensor	Malfunction of humidity sensor	Malfunction of water temperature sensor	Malfunction of jumper cap	Webside address of indoor unit is abnormal	PCB of wired controller is abnormal
Outdoor	E	High discharge temperature protection of compressor 2	High discharge temperature protection of compressor 3	High discharge temperature protection of compressor 4	High discharge temperature protection of compressor 5	High discharge temperature protection of compressor 6	High discharge temperature protection of compressor 6	—
	F	Malfunction of discharge temperature sensor of compressor 2	Malfunction of discharge temperature sensor of compressor 3	Malfunction of discharge temperature sensor of compressor 4	Malfunction of discharge temperature sensor of compressor 5	Malfunction of discharge temperature sensor of compressor 6	Malfunction of discharge temperature sensor of compressor 6	Current sensor of compressor 1 is abnormal
	J	Overcurrent protection of compressor 6	4-way valve back flow protection	High pressure ratio protection of system	Low pressure ratio protection of system	Freeze prevention protection of system	Freeze prevention protection of system	—
	b	Malfunction of suction temperature sensor 1	Malfunction of suction temperature sensor 2	Malfunction of outdoor humidity sensor	Malfunction of heat exchanger temperature sensor	Malfunction of oil-return humidity sensor	Malfunction of oil-return humidity sensor	Clock of system is abnormal
	P	Drive IPM module protection of compressor	Malfunction of drive temperature sensor of compressor	Drive IPM module protection of compressor	Desynchronization protection of inverter compressor	—	—	High-voltage protection of compressor's drive DC bus bar
	H	Drive IPM module protection of fan	Malfunction of drive temperature sensor of fan	Drive IPM module protection of fan	Desynchronization protection of inverter fan	—	—	High-voltage protection of fan's drive DC bus bar
Debugging	U	Alarm because valve is abnormal	—	Malfunction of pipeline for indoor unit	Malfunction of pipeline for outdoor unit	—	—	—
	C	Alarm because number of outdoor unit is inconsistent	—	Emergency status of compressor	Emergency status of fan	Emergency status of module ; indoor unit can't display	Emergency status of module ; indoor unit can't display	Rated capacity is too high
Status	A	Heat pump function setting	Quiet mode setting	Vacuum pump mode	—	—	—	Heating
	n	Inquiry of malfunction of unit	Inquiry of parameters	Inquiry of project series number of indoor unit	—	—	Heat pump unit	Heating only unit

DC Inverter VRF Units

Distinguish symbol		Content symbol	H	G	L	E	F	J
Indoor	L	Alarm because the air quality is bad	Alarm because the air quality is bad	Models for indoor unit and outdoor unit isn't matching	—	—	—	—
	d	PCB of wired controller is abnormal	Abnormal capacity address setting	Malfunction of air-outlet temperature sensor	Malfunction of indoor CO ₂ sensor	—	—	—
Outdoor	E	—	Drop protection of discharge temperature sensor of compressor 1	Drop protection of discharge temperature sensor of compressor 2	Drop protection of discharge temperature sensor of compressor 3	Drop protection of discharge temperature sensor of compressor 4	Drop protection of discharge temperature sensor of compressor 5	Drop protection of discharge temperature sensor of compressor 6
	F	Current sensor of compressor 1 is abnormal	Current sensor of compressor 2 is abnormal	Current sensor of compressor 3 is abnormal	Current sensor of compressor 4 is abnormal	Current sensor of compressor 5 is abnormal	Current sensor of compressor 6 is abnormal	Current sensor of compressor 6 is abnormal
	J	—	Water-flow switch protection	High-pressure protection	—	—	—	—
	b	Clock of system is abnormal	Drop protection of discharge temperature sensor of compressor 1	Drop protection of discharge temperature sensor of compressor 2	—	—	—	—
	P	High-voltage protection of compressor's drive DC bus bar	Drive current detection circuit malfunction of compressor	Low-voltage protection of compressor's drive DC bus bar	Phase-lacking of inverter compressor	Drive charging circuit malfunction of compressor	Failure startup of inverter compressor	Failure startup of inverter compressor
	H	High-voltage protection of fan's drive DC bus bar	Drive current detection circuit malfunction of fan	Low-voltage protection of fan's drive DC bus bar	Phase-lacking of inverter fan	—	Failure startup of inverter fan	Failure startup of inverter fan
Debugging	U	—	Setting of main indoor unit is successful	Abnormal compressor emergency setting	Charging of refrigerant is invalid	—	—	—
	C	Rated capacity is too high	No malfunction of main control unit	Rated capacity is too low	—	Malfunction of multi main control unit	Button-dial of system address shocks	Button-dial of system address shocks
Status	A	Heating	Cooling	—	Charging refrigerant manually	Fan	Alarm for cleaning filter	Alarm for cleaning filter
	n	Heating only unit	Cooling only unit	—	Negative sign code	Fan model	—	—

Distinguish symbol		Content symbol		p	U	b	d	n	y
Indoor	L	—	—	—	—	—	—	—	—
	d	—	—	Project debugging code		—	—	—	—
Outdoor	E	Drop protection of discharge temperature sensor of compressor 6	High-temperature protection of shell of compressor 1	High-temperature protection of shell of compressor 2	—	—	—	—	—
	F	—	Malfunction of shell temperature sensor of compressor 1	Malfunction of shell temperature sensor of compressor 2	—	—	—	—	—
	J	—	—	—	—	—	—	—	—
	b	—	—	—	—	—	—	—	—
	P	AC current protection of inverter compressor	—	—	—	—	—	—	—
	H	AC current protection of inverter fan	—	—	—	—	—	—	—
Debugging	U	—	—	—	—	—	—	—	—
	C	Malfunction of multi main wired controller (display of wired controller)	Communication malfunction between indoor unit and receiving lamp plate	Overflowing distribution of IP address	—	—	—	—	—
Status	A	Debugging confirmation for startup of unit	Long-distance stop operation suddenly	Stop operation suddenly	Limit operation	—	—	—	—
	n	—	—	—	—	—	—	—	—

8 Maintenance and Care

Regular check, Maintenance and care should be performed every six months by professional personnel, which will prolong the unit life span. Disconnect the power supply before cleaning and maintenance.

8.1 Outdoor Heat Exchanger

Outdoor heat exchanger is required to be cleaned once every six months. Use vacuum cleaner with nylon brush to clean up dust and sundries on the surface of heat exchanger. Blow away dust by compressed air if it is available. Never use water to wash the heat exchanger.

8.2 Drain Pipe

Regularly check if the drain pipe is clogged in order to drain condensate smoothly.

8.3 Notice before Seasonal Use

- (1) Check if the inlet/outlet of the indoor/outdoor unit is clogged.
- (2) Check if the ground wire is earthed reliably.
- (3) Check if battery of remote wireless controller has been replaced.
- (4) Check if the filter screen has been set soundly.
- (5) After long period of shutdown, open the main power switch 8 hours before reoperating the unit so as to preheat the compressor crankcase.
- (6) Check if the outdoor unit is installed firmly. If there is something abnormal, please contact the GREE appointed service center.

8.4 Maintenance after Seasonal Use

- (1) Cut off main power supply of the unit.
- (2) Clean filter screen and indoor and outdoor units.
- (3) Clean the dust and sundries on the indoor and outdoor units.

(4) In the event of rusting, use the anti-rust paint to stop spreading of rust.

8.5 Parts Replacement

Purchase parts from Gree appointed service center or dealer if necessary.

Note:

During airtight and leakage test, never mix oxygen, ethyne and other dangerous gas into refrigeration circuit. In case of hazard, it's better to use nitrogen or refrigerant to accomplish such test.

9 After-sales Service

In case the air-conditioning unit you bought has any quality problem or you have any inquiry, please contact the local after-sales service agency designated by Gree.

Warranty should meet the following requirements:

- (1) First run of the unit should be operated by professional personnel from Gree appointed service center.
- (2) Only Gree manufactured accessories can be used on the machine.
- (3) All the instructions listed in this manual should be followed.
- (4) Warranty will be automatically invalid if fails to obey any item mentioned above.



66129919994